



TOOL SUPPORT SYSTEMS

2017 / 18



AIMCO

For over 40 years AIMCO has been working with manufacturers around the world, we are the complete global source for all assembly, fastening, and critical bolting needs. AIMCO can effectively and swiftly meet your needs whether you're in Thailand fastening a 3 mm nut at 3 Nm, or in Tennessee, USA torquing the last lug nut. AIMCO provides the tools and solutions, on a global scale, that guarantee the success of your project. It is with great pride that AIMCO can say the products that we manufacture are **MADE IN THE USA.**

ISO 9001: 2015 Certified

Visit our NEW website www.aimco-global.com

TABLE OF CONTENTS

TOOL SUPPORT SYSTEMS

GRAVITY DEFYING BALANCERS	4
LINE REEL BALANCERS / RETRACTORS	5
ERGO-ARM® TOOL SUPPORT SYSTEMS	6
CUSTOM REACTION DEVICES	7
ERGO-ARM® ACCESSORIES / LINEAR ARM	7
GCI TORQUE REACTION ARMS	8
CARBON TORQUE ARMS / TUBES	10
WORKSTATION COMPONENTS AND ASSEMBLIES	12
AIR PREPARATION UNITS	14
AIR LINE & ACCESSORIES	15
INDEX17



GRAVITY-DEFYING BALANCERS

TW-SERIES BALANCERS



TW-0 & TW-00 Series

TW-0 and TW-00

- Gravity defying / "true balance"
- No tension buildup to cause worker fatigue
- Easy external direct drive tensioning
- 360 degree upper swivel
- Safety cable provision
- Tool clip included



TW-3 through TW-70

- Tapered drum allows "true balance" throughout cable travel
- Easy external direct drive tensioning
- Cast aluminum casing for durability
- Permanent lubrication
- 360 degree top swivel

TW-3 to TW-70 Series

- Enclosed spiral spring for added safety
- Safety chain provision (TW-3 through TW-15 models)
- Automatic safety lock plus manual drum lock (TW-22 through TW-70)

MODEL	CAPACITY		ANTI-GRAVITY CAPACITY (LB)	CABLE
	LB	KG		
TW-00	1.1 - 3.3	0.5 - 1.5	2.5 - 3.0	18" stranded steel cable 1/8 dia.
TW-0	1.1 - 3.3	0.5 - 1.5	2.5 - 3.0	3.3-ft stranded steel cable 1/8" dia.
TW-3	2.2 - 6.6	1.0 - 3.0	4.5 - 6.0	4.3-ft stranded steel cable 5/32" dia.
TW-5	5.5 - 11.0	2.5 - 5.0	8.0 - 10.5	4.3-ft stranded steel cable 5/32" dia.
TW-9	9.9 - 19.8	4.5 - 9.0	15.0 - 19.0	4.3-ft stranded steel cable 5/32" dia.
TW-15	19.8 - 33.0	9.0 - 15.0	26.0 - 32.5	4.3-ft stranded steel cable 5/32" dia.
TW-22	33.0 - 48.4	15 - 22	41.0 - 48.0	5-ft stranded steel cable 3/16" dia.
TW-30	48.4 - 66.0	22 - 30	58.0 - 65.5	5-ft stranded steel cable 3/16" dia.
TW-40	66.0 - 88.0	30 - 40	77.5 - 87.5	5-ft stranded steel cable 3/16" dia.
TW-50	88.0 - 110.0	40 - 50	100.0 - 109.5	5-ft stranded steel cable 3/16" dia.
TW-60	110.0 - 132.0	50 - 60	122.0 - 131.0	5-ft stranded steel cable 3/16" dia.
TW-70	132.0 - 154.0	60 - 70	144.0 - 153.0	5-ft stranded steel cable 3/16" dia.

ASB-SERIES BALANCERS

- Built-in Safety Features: The cable, drum, and enclosed spring are fully visible without opening the unit for easy and convenient safety checks. The sturdy spiral spring is enclosed for greater control and safety
- Ergonomic Spring Release: The automatic safety lock provides extra control
- Extended Cable Length: Stainless steel cables allow for extended reach on applications
- Enhanced Gear Mechanism: Allows for more exact adjustment of tension
- No Recoil and Low Resistance: Tapered drum style provides gravity defying tool positioning and low travel



ASB-OC Gravity Defying and Hand Adjustable Balancer



**ASB-3C
ASB-5C**

MODEL	CAPACITY		STROKE		WEIGHT	
ASB-OC	1.1 - 3.3 lb	0.5 - 1.5 kg	51.1 in	130 cm	1.5 lb	0.7 kg
ASB-3C	3.3 - 6.6 lb	1.5 - 3 kg	86.4 in	220 cm	3.0 lb	1.4 kg
ASB-5C	5.5 - 11 lb	2.5 - 5 kg	86.4 in	220 cm	3.4 lb	1.5 kg

LINE REEL BALANCERS / RETRACTORS

LINE REEL BALANCERS

LR-Series

- Designed for light duty applications with small pneumatic tools
- Integrating air hose and support cable keep work areas clean
- Adjustable ball stop for optional positioning
- 1/4" I.D. polyvinyl hose with 1/4" NPT inlet
- 360 degree upper swivel
- Maximum 142 PSI



LR-09B-90/200

MODEL	HOSE LENGTH		CAPACITY	
LR-09B-90	35.5 in	90 cm	3 lb	1.5 kg
LR-09B-200	78.3 in	199 cm	3 lb	1.5 kg

RETRACTORS

RPA Series

- No tools needed to set tension
- 5 ft nylon coated steel cable
- Reinforced hanging bracket includes safety cable provision
- Adjustable cable stop
- Three (3) models support weight 0.5 – 5 lb
- Tool clip included



RMA-L Series



RPA Series

RMA-L Series

- Steel housing with polyester finish
- Reinforced hanging bracket includes safety cable provision
- 8 ft of 3/32" diameter coated steel cable
- Permanently lubricated
- Tool clip included
- External tension adjustment
- Ratchet cable lock

MODEL	CAPACITY	
RPA-1	0.5 - 1.5 lb	0.2 - 0.7 kg
RPA-2	1.5 - 3.0 lb	0.7 - 1.4 kg
RPA-3	3.0 - 5.0 lb	1.4 - 2.3 kg
RMA-7L	5 - 10 lb*	2.3 - 4.8 kg*
RMA-15L	10 - 15 lb*	4.5 - 6.8 kg*
RMA-20L	15 - 23 lb*	6.8 - 10.4 kg*

* With ratchet lock

ERGO-ARM TOOL SUPPORT SYSTEMS

FEATURES AND BENEFITS

- Ergonomic support for electric and pneumatic tools reduces operator fatigue
- Increases productivity, consistency, and accuracy



AD-D1098-PAC



AD-D1098-SAC

PARALLEL ARM SERIES

AD-D1098-P, AD-D1098-PAC, AD-D1098-PACE

- Minimizes operator control
- Vertical adjustment eliminates cross-threading
- Fixtured tool increases repeatability
- Adjustable reach
- Available in air or oil cylinder models
- Electric tool mount standard on PACE model

SINGLE ARM SERIES

AD-D1098-S, AD-D1098-SAC

- Full tool rotation
- Operator control
- Adjustable reach
- Compatible with automatic screw feeder
- Available in air or oil cylinder models

MODEL	ARM STYLE	TOOL MOUNT	REACH		CAPACITY		MAXIMUM TORQUE*	
			IN	MM	LB	KG	IN-LB	NM
AIR CYLINDER SERIES								
AD-D1098-SAC	Single	Air manifold	4 - 33	102 - 838	0 - 15	0 - 7	110	12
AD-D1098-PAC	Parallel	Air manifold	4 - 33	102 - 838	0 - 15	0 - 7	110	12
AD-D1098-PACE	Parallel	Electric	4 - 33	102 - 838	0 - 15	0 - 7	110	12
OIL CYLINDER SERIES								
AD-D1098-S	Single	Air manifold**	4 - 33	102 - 838	0 - 15	0 - 7	110	12
AD-D1098-P	Parallel	Air manifold	4 - 33	102 - 838	0 - 15	0 - 7	110	12

* Max torque allowed may be dependent on tool clutch type and joint rate

** For single arm electric tool mount, order EAP-202ED-KIT

SPECIAL FEATURES OF CLASSIC STYLE ERGO-ARM

Dual ball bearing joint construction for smoother movement and long life

Air regulator offers precision adjustment of resistance for perfect balance

Unique upper rail adjustment allows true vertical approach to any fastener – no cross-threading

ERGO-ARM ACCESSORIES AND LINEAR ARM

ERGO-ARM ACCESSORIES

- End-of-Arm Tooling options for the Ergo-Arm allow you to choose the style right for your application
- Tool holders permit the tool to swivel, rotate, swing, or twist. Heavy duty construction can lock out any single, or combination of rotating, actions allowing only the motions required by your application
- End-of-Arm Tooling Brackets are simple to use. One Ergo-Arm can be used for more than one application

FOR USE WITH MODELS
AD-D1098-S/SAC



EAP-202ED-KIT
Electric Driver Tool
Mount Kit

FOR USE WITH MODELS
AD-D1098-P/PAC



EAP-203-ASSY
Air Manifold
Tool Mount Kit
(Standard on
parallel units)



EAP-202ASSY
Driver Tool
Mount

LINEAR ARM

- Smooth movement and perfect balance while limiting operator control
- Machined stainless steel and ball bearing construction
- Two high quality tool balancers are included with each arm to provide a wide range of adjustment

LINEAR ARM KIT



LQ-0002 Linear Arm
ships with two ASB-0C
balancers.

LQ-0004 Linear Arm
ships with two TW-3
balancers.

**LQ-0024H Heavy Duty
Arm**
ships with two TW-3
balancers.

PARALLEL ARM KIT



EAA-04 - Provides easy
conversion of standard Ergo-
Arms to the parallel style.

MODEL	DESCRIPTION	MAX. REACH		WEIGHT CAPACITY		MAX TORQUE		HEIGHT		STANDARD TOOL MOUNT DIAMETER	
		IN	CM	LB	KG	FT-LB	NM	IN	CM	IN	CM
LQ-0002	Linear Arm	14	37	1-5	0.5 - 2.3	20	27	24	61	1.6	4.1
LQ-0004	Linear Arm	24	58	3 - 10	1.4 - 4.5	25	34	36	91.4	1.6	4.1
LQ-0024H	Heavy Duty Arm	24	58	3 - 10	1.4 - 4.5	75	102	36	91.4	1.6	4.1

CUSTOM REACTION DEVICES

- Torque Tubes
- Articulating Torque Arms
- Ergo Arm 3 Zero Gravity Arms
- Smart Arms



**Articulating
Smart Carbon
Arm**



**Articulating
Torque Arm**



**Carbon Fiber
Arm**



Ergo-Arm 3



Torque Tube

Contact an AIMCO Customer Service Associate, 1-800-852-1368, in order to determine the exact torque reaction system needed to improve the productivity and ergonomics of your assembly station.

GCI TORQUE REACTION ARMS

RUGGED FLEXIBILITY FOR EVEN THE MOST COMPLEX TORQUE APPLICATIONS



Carbon Fiber Arm

Constructed of durable aluminum, steel, or carbon fiber, GCI Torque Arms are available with multiple tool mounting options for application specifics. These highly ergonomic and user friendly arms are available in torque ranges of 150 Nm to 7,500 Nm and with reaches ranging up to 20 ft.

GCI arms can be designed as Smart Arms with encoders and intuitive PC-based AdaptiCS software. This complete Smart Arm system error-proofs even the most complex torque applications.

FEATURES AND BENEFITS

- Available in aluminum, steel, or carbon fiber
- Configurable installation: floor mount, wall mount, overhead mount, bench mount, or portable base
- Braking options: manual/automatic, discrete braking with verification, parking brakes, and electric/pneumatic actuation
- Tool holding options: fixed position, gimbal mount
- Integrated tool start/brake actuation capability: tool trigger start, remote tool start
- Smart Arm Capabilities:
 - Available with as many as six encoders to monitor all desirable tool positions relative to application
 - Intuitive, user-friendly AdaptiCS PC-based software that runs on an integrated industrial PC or on a customer supplied PC
 - Accepts easily scalable part images



Rugged tablet PC option for Smart Arm

MODEL	MAX. TORQUE	MAX. TOOL WEIGHT	MAX. REACH	MAX. VERTICAL TRAVEL	CONSTRUCTION
IPT SERIES - TORQUES TO 375 NM					
IPT150	150 Nm	12 lb	5 ft	30 in	Aluminum
IPT375	375 Nm	50 lb	6 ft	36 in	Steel
IP SERIES - TORQUES TO 4,000 NM					
IP4	550 Nm	30 lb	8 ft	48 in	Steel
IP5	1,000 Nm	50 lb	12 ft	60 in	Steel
IP7	3,000 Nm	100 lb	12 ft	60 in	Steel
IP8T	4,000 Nm	100 lb	12 ft	72 in	Steel
F SERIES - CARBON FIBER ARMS					
F70	70 Nm	10 lb	3 ft	18 in	Carbon Fiber Composite
F600	600 Nm	50 lb	20 ft	72 in	Carbon Fiber Composite
F1500	1,500 Nm	50 lb	20 ft	72 in	Carbon Fiber Composite
F3000	3,000 Nm	75 lb	20 ft	72 in	Carbon Fiber Composite
F7500	7,500 Nm	75 lb	12 ft	72 in	Carbon Fiber Composite

GCI TORQUE REACTION ARMS

FEATURES

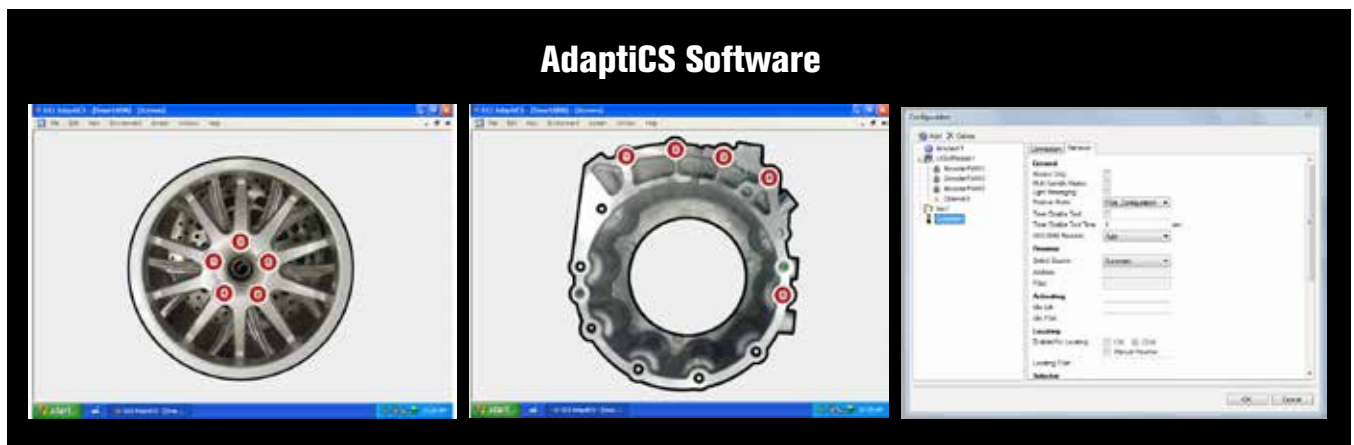
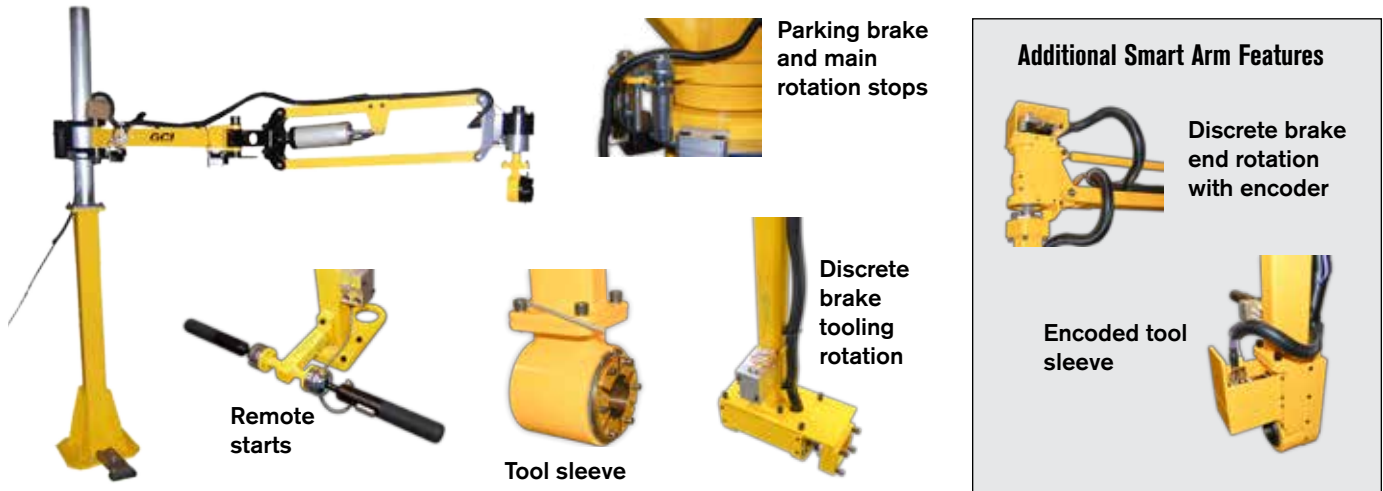

- Batch count capabilities
- Bidirectional arm articulation tracking
- Full torque/angle results display
- Integrates into any line control (PLC, MES, etc.)
- Multiple part locate strategies (1-point, 2-point, 3-point)
- Fully programmable dynamic display with integrated PC option
- Multiple rework strategies to fit customer requirements
- Integrates devices such as torque controllers via open protocol, encoded GCI torque reaction arms, scanners, vision cameras, and digital IO (pass/fail)
- AdaptiCS Enterprise (optional) provides full line control, interlocks, and data collection
- Runs on Windows 7, 8, and 10

CARBON TORQUE ARMS / TUBES

CARBON TORQUE ARMS / TUBES

Carbon Arms and Carbon Torque tubes are lightweight, yet strong devices designed to absorb torque reactive forces. Highly flexible and modular, they adapt to a wide range of tools, and eliminate hazards to operators during fastening processes.



FEATURES AND BENEFITS

- Absorb torque reaction from continuous drive tools
- Counter balance tool weight when configured with AIMCO's wide array of tool balancers (page 4) or with integrated balancer kits
- Orient tool correctly to the workpiece to improve efficiency and reduce operator effort in alignment to the fastener

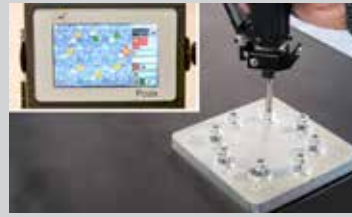

ACA-POSIX POSITIONING SYSTEM

The compact, self-contained

ACA-Posix process visualization system guides operators through their assigned tasks. It connects to ACA-P2 series arms with integrated balancer kits.

FEATURES AND BENEFITS

- Intuitive and simple programming on 7" color LCD touch-screen display
- Store up to 500 unique assembly sequences
- Communicates directly with Power Tool controllers over digital I/O
- Store and display product images or CAD drawings. Images/drawings are displayed with targeting sequences to direct operators easily through their task
- Output for synchronizing with line controls

TELESCOPIC TORQUE ARMS

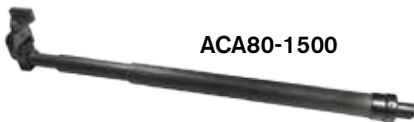

ACA80-1500



ACA-V15-1000



ACA-P240-2500

ACA Series

MODEL	MIN. LENGTH MM	MAX. LENGTH MM	MAX TORQUE NM
ACA10-1000	495	1105	10
ACA10-1500	665	1605	10
ACA15-1000	486	1066	15
ACA15-1500	646	1556	15
ACA15-2000	806	2046	15
ACA40-1000	486	1066	40
ACA40-1500	646	1556	40
ACA40-2000	806	2046	40
ACA40-2500	986	2576	40
ACA80-1500	658	1586	80
ACA80-2000	828	2078	80
ACA80-2500	998	2588	80
ACA150-1500	668	1578	150
ACA150-2000	838	1918	150
ACA150-2500	1003	2248	150
ACA220-1500	668	1578	220
ACA220-2000	838	2088	220
ACA220-2500	1003	2588	220

ACA-V Series

MODEL	MIN. LENGTH MM	MAX. LENGTH MM	MAX TORQUE NM
ACA-V15-1000	777	1345	15
ACA-V15-1500	937	1835	15
ACA-V15-2000	1097	2325	15
ACA-V40-1000	777	1345	40
ACA-V40-1500	937	1835	40
ACA-V40-2000	1097	2325	40
ACA-V40-2500	1277	2855	40
ACA-V80-1500	949	1865	80
ACA-V80-2000	1119	2357	80
ACA-V80-2500	1289	2867	80
ACA-V150-1500	960	19575	150
ACA-V150-2000	1129	2357	150
ACA-V150-2500	1294	2862	150
ACA-V220-1500	960	19575	220
ACA-V220-2000	1129	2357	220
ACA-V220-2500	1294	2867	220

ACA-P2 Series X,Y Axis Encoders

(Requires ACA-POSIX System)

MODEL	MIN. LENGTH MM	MAX. LENGTH MM	MAX TORQUE NM
ACA-P215-1000	647	1227	15
ACA-P215-1500	803	1713	15
ACA-P215-2000	977	2227	15
ACA-P240-1000	647	1227	40
ACA-P240-1500	803	1713	40
ACA-P240-2000	977	2227	40
ACA-P240-2500	1157	2737	40
ACA-P280-1500	830	1757	80
ACA-P280-2000	1000	2249	80
ACA-P280-2500	1169	2760	80
ACA-P2150-1500	839	1749	150
ACA-P2150-2000	1009	2087	150
ACA-P2150-2500	1174	2419	150
ACA-P2220-1500	839	1749	220
ACA-P2220-2000	1009	2259	220
ACA-P2220-2500	1174	2760	220

CARBON TORQUE ARMS / TUBES

ANTI-ROTATION TORQUE ARMS



ACTT-V40-850 300



ACPTT-V40-SA-510 150

ACTT SERIES TORQUE TUBES

MODEL	MIN. LENGTH MM	MAX. LENGTH MM	MAX TORQUE NM
ACTT-V15-600 150	150	600	15
ACTT-V15-800 300	300	800	15
ACTT-V40-600 150	150	600	40
ACTT-V40-850 300	300	850	40
ACTT-V40-1500 600	600	1500	40
ACTT-V80-900 300	300	900	80
ACTT-V80-1500 600	600	1500	80
ACTT-V80-2100 900	900	2100	80

ACPTT SERIES TORQUE TUBES FOR ACSA ARTICULATING SUPPORT ARMS

MODEL	MIN. LENGTH MM	MAX. LENGTH MM	MAX LENGTH MM
ACPTT-V15-510 150	150	600	15
ACPTT-V15-710 300	300	800	15
ACPTT-V40-510 150	150	600	40
ACPTT-V40-760 300	300	850	40
ACPTT-V40-1410 600	600	1500	40
ACPTT-V80-810 300	300	900	80
ACPTT-V80-1410 600	600	1500	80

ACCESSORIES

TOOL HOLDERS

	MODEL	DESCRIPTION	MIN. TOOL GRIP (MM)	MAX. TOOL GRIP (MM)
FOR TELESCOPIC ARMS				
	ACAH-15	Base tool holder 4 screws	27	45
	ACAH-40-80	Base tool holder 4 screws	30	60
	ACAH-150-220	Base tool holder 4 screws	40	70
Multi-Position				
	ACAH-15-MPE2745	Multi-position tool holder interface	27	45
	ACAH-150220-MPE4070	Multi-position tool holder	40	70
	ACAH-4080-MPE2745	Multi-position tool holder	27	45
Swivel				
	ACAH-S154080	Swivel tool holder 20 to 35 mm	20	35
	ACAH-SL15150	Swivel tool holder 40 to 55 mm	40	55

	MODEL	DESCRIPTION	MIN. TOOL GRIP (MM)	MAX. TOOL GRIP (MM)
FOR ANTI-ROTATION ARMS				
	ACAHTT-15A-3060	Angle Tool Holder - 15 Nm Arm	30	60
	ACAHTT-15S-2745	Straight Tool Holder - 15 Nm Arm	27	45
	ACAHTT-4080A-3165	Angle Tool Holder - 40/80 Nm Arms	31	65
	ACAHTT-40S-2745	Straight Tool Holder - 40/80 Nm Arms	27	45



ACSA ARTICULATING SUPPORT ARMS



ACSA-600-1500

MODEL	MAX REACH MM	MAX HEIGHT MM	MAX TORQUE NM
ACSA-600-1500	600	1500	80
ACSA-800-1500	800	1500	80
ACSA-1000-1500	1000	1500	80

BALANCER KITS FOR ACA-P2 SERIES

MODEL	MIN. CAPACITY (KG)	MAX. CAPACITY (KG)
ACA-P2BK-4	2	4
ACA-P2BK-6	4	6
ACA-P2BK-8	6	8
ACA-P2BK-10	8	10
ACA-P2BK-14	10	14



ACA-P2BK-10

WORKSTATION COMPONENTS AND ASSEMBLIES

COMPONENTS

TRACK

Steel with beige polyester finish. Use for vertical and horizontal workstation support.

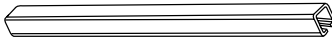

PART NUMBER	30# TRACK
AT3-3	3 ft track
AT3-4	4 ft track
AT3-6	6 ft track
AT3-9*	9 ft track

PART NUMBER	30# TRACK
AT5-3	3 ft track
AT5-4	4 ft track
AT5-6	6 ft track
AT5-9*	9 ft track
AT5-12*	12 ft track

TRACK NUT (ATN-3/5)

Zinc plated steel. Use to attach accessories to track, as end stops, or to isolate rolling accessories.

- ATN-3 for 30 lb. track
- ATN-5 for 50 lb. track



END STOP (AES-3/5)

Zinc oxide finish. Use to prevent balancer trolley from "overtouring" horizontal track.

- AES-3 for 30 lb. track
- AES-5 for 50 lb. track

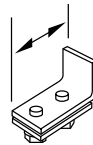

MOUNTING PLATE (AMP-5)

Black polyester finish. Use as a base to mount vertical uprights.

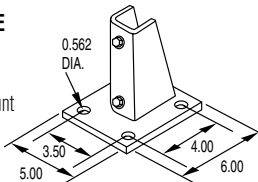

END CAP (AEP-3/5)

Black molded vinyl. Use to cap track ends for a professional finish.

- AEP-3 for 30 lb. track
- AEP-5 for 50 lb. track

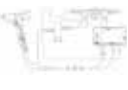

ANGLE BRACKET (AB-3/5)

Black polyester finish. Use to mount horizontal track to vertical track.

- AB-3 for 30 lb. track
- AB-5 for 50 lb. track

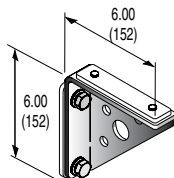

JOINT HANGER BRACKET (AJH-3/5)

Black polyester finish. Use to couple and hang end-to-end track.

- AJH-3 for 30 lb. track
- AJH-5 for 50 lb. track

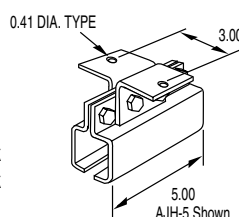

BALANCER TROLLEY (ABT-3/5)

Black polyester finish. Use as moving support for tool balancers, hose, and cable. Quality ball bearing wheels for long life and smooth tracking.

- ABT-3 for 30 lb track (1.00 dia)
- ABT-5 for 50 lb track (1.25 dia)

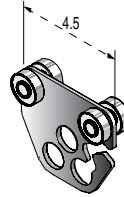

HANGER BRACKET (AHB-3/5)

Black polyester finish. Use to suspend track at right angle.

- AHB-3 for 30 lb. track
- AHB-5 for 50 lb. track

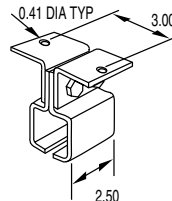

VERTICAL COLUMN (AVC-5*)

Beige polyester finish, 3" diameter x 9 ft upright steel column with welded base. Use as floor mount for extra stability with jibs or workstation components.

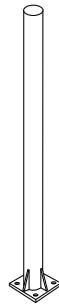

HOSE/CABLE TROLLEY

Black polyester finish. Use for moving cable or hose festoon. Supports hose cable OD .60-.94.

- AIC3-2 for 30 lb. track
- AIC5-2 for 50 lb. track

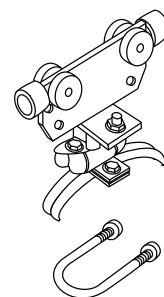

U-BOLTS (AUB-5)

Zinc plated steel. Use to secure boom bracket, or any flat metal plate, to AVC-5 (sold individually).



END CLAMP (AEC5-2)

Black polyester finish. Use as end stop with hose carrier for festoon. Cable/hose OD .60-.94.

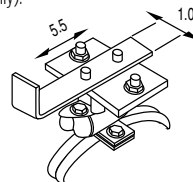

SUPPORT CLAMPS (ASC-3/5)

Black polyester finish. Use as additional support for track.

- ASC-3 for 30 lb. track
- ASC-5 for 50 lb. track

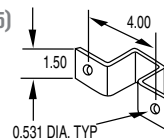

TOOL CLIP (SH-5)

Steel clip with safety latch. Use for tool attachment and as replacement clip for lightweight tool balancers. Measures 2.37" long.



ROLLING HANGER (ABT5-R)

Black polyester finish. Use as support for rolling track. Allows X/Y axis movement, includes ball bearing wheels.

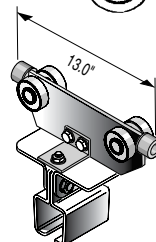

90° CONNECTOR FOR 3/8" HOSE (WSCH)

3/8" I.D. Brass. Use to provide stable transfer point from air line to tool. 90 degree connector attaches to ABT-5.

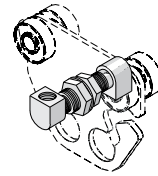

WALL- AND FLOOR-MOUNTED JIBS

3 FT. SWINGING JIB (AW3S)

3 FT. FIXED JIB (AW3F)

3 FT. SWINGING JIB FOR CHANNEL MOUNT (AJS3**)

Jibs are mounted to wall or beams to create free standing workstations. End stop, end cap, and balancer trolley included. Maximum weight: 30 lb.

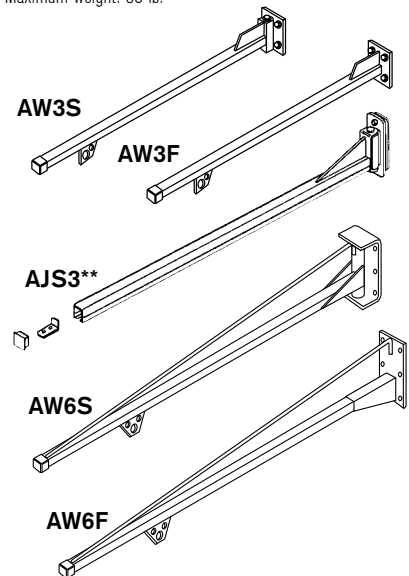

6 FT. SWINGING JIB (AW6S)

6 FT. FIXED JIB (AW6F)

Jibs can be wall mounted or attached to vertical column (AVC-5) to create a freestanding workstation. End stop, end caps, and balancer trolley are included. Maximum weight: 50 lbs.

All complete assemblies are beige polyester finish and include balancer trolley, end caps, and end stops. Floor mounted assemblies are not able to ship via UPS.

When choosing a workstation system, remember...

Total weight capacities should include tool balancer, hose/cable, and tool/fixture. Units need to be supported vertically and horizontally every 6 ft.

* Additional freight may apply

** AJS3 Does not include balancer trolley

WORKSTATION COMPONENTS AND ASSEMBLIES

**FLOOR MOUNTED
3 FT. SWINGING JIB***
(AW3FMS)

**FLOOR MOUNTED
3 FT. FIXED JIB***
(AW3FMF)

Maximum weight: 30 lb
Column height: 6 ft

**FLOOR MOUNTED
6 FT. SWINGING JIB***
(AW6FMS*)

**FLOOR MOUNTED
6 FT. FIXED JIB***
(AW6FMF*)

Maximum weight: 50 lb
Column height: 9 ft

*Units include end stop,
balancer trolley and intermediate carrier.

BENCH MOUNTED SWINGING JIB (JJ30-S)
BENCH MOUNTED FIXED JIB (JJ30)

Maximum weight: 30 lbs
Column height: 48" including mounting plate
3 ft. swinging jib includes balancer
trolley, end stop, and cap

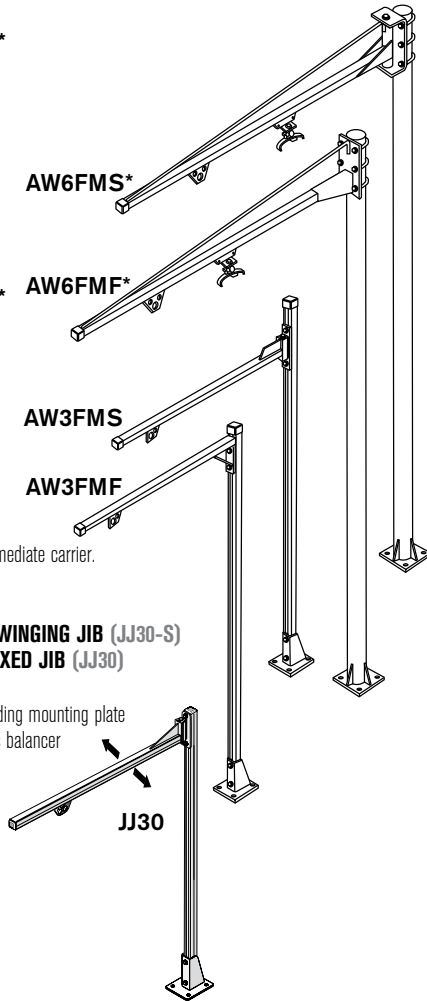

AIMCO WORKSTATION KIT

**BENCH MOUNTED WORKSTATION
WITH TORQUE ARM (JJ30-TA**)**

- 5 lb. maximum weight (RPA-3 included)
- 5' column height including mounting plate
- 38" jib length (swinging)
- 15 ft-lb torque rating
- 3/8" NPT inlet
- 1/4" NPT outlet
- Beige polyester finish
- 1/4" braided air hose
- 21" maximum vertical arm travel

**Additional freight may apply
**For use with pneumatic tools only

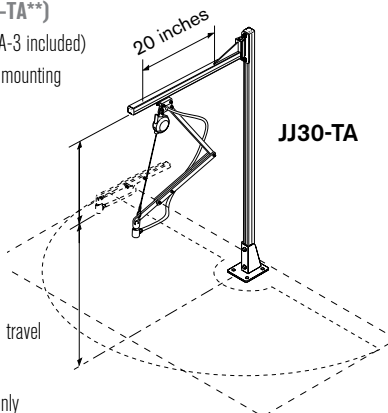

CREATE A CUSTOM SUPPORT SYSTEM USING AIMCO'S QUALITY PRODUCTS

- Organize work area to create a safe, productive working environment
- Reduce risk of injury to assembler by providing support for heavy tools
- Protect valuable tools, fixtures, and monitoring devices from damage by suspending them out of the way

AIMCO BASIC WORKSTATION KIT (ATW-50)



- 50 lb maximum weight capacity
- 48" uprights
- 36" extensions
- Table mounts included
- 6' tool rail with rolling trolley included
- All necessary hardware included

TROLLEY MOUNTED TORQUE ARM WITH 3-LB RETRACTOR AND HOSE (FA-50-2*)

Ergonomic arm absorbs torque reaction.
Moves front to back along overhead jib.

(TA-50-2)

Moves side to side on overhead track.

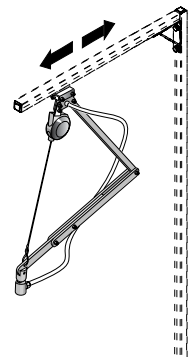

AIMCO can customize a workstation for you.
Contact an AIMCO Customer Service Associate
1-800-852-1368.

AIR PREPARATION UNITS

AFRL STACKING FILTER/REGULATORS

Stacking filter/regulator combinations provide air filtration and precise regulation in a single unit for easy mounting and installation.

FEATURES AND BENEFITS

- All models include L-mount bracket, gauge, and metal bowl shields
- Polycarbonate filter and lubricator bowls (metal bowls standard on AFRL-8)
- 25-micron filter included on all models
- Regulating range: 7 – 125 PSI
- Custom order upgrade items include metal bowl, 5 micron filter, semi-automatic filter drain, and reduced PSI range regulator. Contact an AIMCO Customer Service Associate for more information, 1-800-852-1368



**AFRL-2-C
AFRL-3-C**

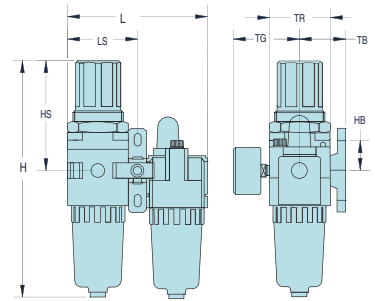

**AFRL-3
AFRL-4
AFRL-8**

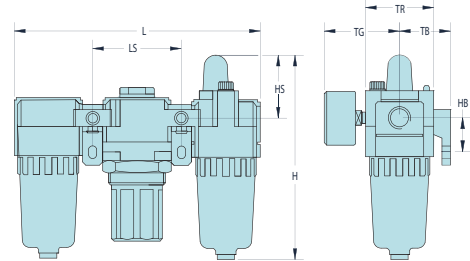

**28178
HT Air Tool/AFRL
Carrying Kit**



**AFRL-4HTA
Standalone Unit**

MODEL	PORT	GAUGE PORT	FLOW RATE CFM	FLOW RATE L/MIN	BOWL SHIELD	H IN/MM	HB IN/MM	HS IN/MM	L IN/MM	LS IN/MM	TB IN/MM	TG IN/MM	TR IN/MM
AFRL-2	1/4"	1/8"	70	2,000	yes	6.16 (156.5)	1.39 (35.3)	1.50 (38.1)	7.13 (181.1)	2.52 (64.0)	1.61 (41.0)	2.39 (60.7)	2.09 (53.1)
AFRL-2-C	1/4"	1/8"	60	1,700	yes	8.31 (211.1)	1.38 (35.1)	3.64 (92.5)	4.61 (117.1)	2.30 (58.4)	1.61 (40.9)	2.39 (60.7)	2.09 (53.1)
AFRL-3	3/8"	1/4"	140	4,000	yes	7.54 (191.5)	1.57 (40.0)	1.61 (40.9)	9.37 (238.0)	3.31 (84.1)	1.97 (50.0)	2.58 (65.5)	2.76 (70.1)
AFRL-3-C	3/8"	1/4"	105	3,000	yes	10.31 (261.9)	1.57 (39.9)	4.41 (112.0)	6.06 (153.9)	3.03 (77.0)	1.97 (50.0)	2.58 (65.5)	2.76 (70.1)
AFRL-4	1/2"	1/4"	140	4,000	yes	7.54 (191.5)	1.57 (40.0)	1.61 (40.9)	9.37 (238.0)	3.31 (84.1)	1.97 (50.0)	2.58 (65.5)	2.76 (70.1)
AFRL-8	1"	1/4"	180	5,000	yes	10.69 (271.5)	1.97 (50.0)	1.89 (48.0)	11.81 (300.0)	4.13 (104.9)	2.75 (69.9)	2.97 (75.4)	3.54 (89.9)

AIR PREPARATION UNITS: BASIC FUNCTIONS

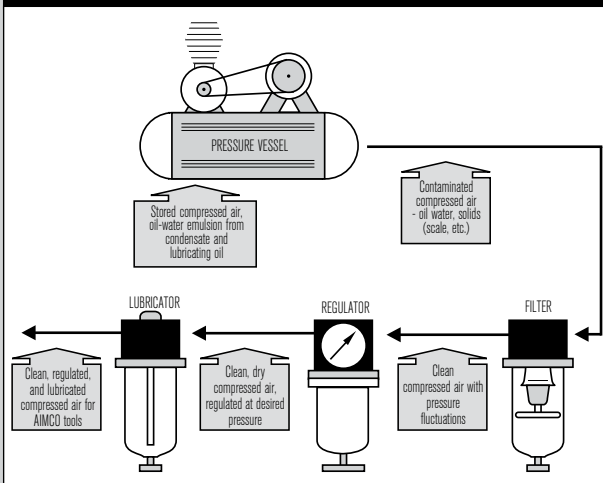

The supply of clean, dry air is essential to the operation of pneumatic powered tools. Use only clean filtered air for longer tool life. Provide proper airflow (CFM) and regulate air pressure (PSI) for optimum performance.

To determine unit size for application, you need to know:

- Total air flow (CFM) required for application
- Size of incoming air line and size of air line required by tool
- Air supply pressure (PSI)
- Allowable pressure drop
- Does the application require lubrication?
- Does the overall system have the required capacity?

AIR LINE

Polyurethane Hose



- Durable Polyurethane is chemical resistant and lightweight, and provides excellent recoil memory and maximum flexibility
- Available in transparent hose color (opaque also available)
- Assemblies for coiled hose include reusable swivel fitting. Straight hose available with or without fittings
- Working temperature: -104° F to 175° F

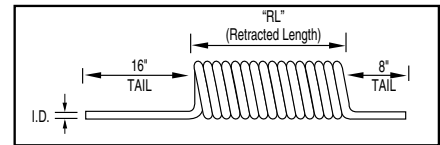

SINGLE AIR HOSE ASSEMBLIES (COILED)

MODEL	DESCRIPTION (O.D. x I.D. x LENGTH)	RETRACTED LENGTH	WORKING PRESSURE	NPT FITTINGS
ASH-250C-10MSZ	3/8" x 1/4" x 10'	7"	100 psi	1/4"
ASH-250C-15MSZ	3/8" x 1/4" x 15'	9 1/2"	100 psi	1/4"
ASH-250C-25MSZ	3/8" x 1/4" x 25'	15 1/2"	100 psi	1/4"
ASH-375C-15MSZ	9/16" x 3/8" x 15'	10"	100 psi	3/8"
ASH-375C-25MSZ	9/16" x 3/8" x 25'	14"	100 psi	3/8"
ASH-500C-15MSZ	3/4" x 1/2" x 15'	13"	100 psi	1/2"
ASH-500C-25MSZ	3/4" x 1/2" x 25'	23"	100 psi	1/2"

Custom length coil assemblies and special colors available in minimum order quantities. Contact an AIMCO Customer Service Associate, 1-800-852-1368.



STRAIGHT AIR HOSE (SOLD PER FOOT)

MODEL	DESCRIPTION
ASH-375Z	3/8" I.D.
ASH-500Z	1/2" I.D.

Contact an AIMCO Customer Service Associate about full reel pricing, 1-800-852-1368.

Rubber Hose



- Designed for use in a wide range of industrial, construction, and agricultural applications
- Constructed of high grade, reinforced EPDM synthetic rubber
- Working temperature: -40° F to 190° F

SINGLE AIR HOSE (RUBBER)

I.D.	O.D.	LENGTH	WORKING PRESSURE	WEIGHT
3/16"	0.44"	10 ft	200 psi	0.8 lb
1/4"	0.5	10 ft	200 psi	0.9 lb
5/16"	0.58	10 ft	200 psi	1.2 lb
3/8"	0.67"	10 ft	200 psi	1.5 lb
1/2"	0.81"	10 ft	200 psi	2.0 lb
5/8"	0.97"	10 ft	200 psi	2.7 lb
3/4"	1.12"	10 ft	200 psi	3.4 lb

Custom lengths available. Contact an AIMCO Customer Service Associate for more details, 1-800-852-1368.

HELPFUL HINTS FOR AIR HOSE USE

- Use recommended I.D. air hose and fittings
- Replace air hose regularly to help maintain clean air
- A clear hose allows you to see water or dirt accumulation in hose
- Use correct length of hose to reduce air loss and pressure drop
- Use locking quick-disconnect couplers for additional safety

AIR LINE ACCESSORIES

BRASS QUICK COUPLERS

Manual ball couplers designed for use with ergonomic twist plugs. Brass with nitrile seals, rated to 300 PSI, from -40° to +250° F.

MODEL	DESCRIPTION
B23	1/4" NPT F x 1/4" QC Brass Coupler
B23E	1/4" NPT F x 3/8" QC Brass Coupler
B25	3/8" NPT F x 3/8" QC Brass Coupler



SWIVEL AIR FITTINGS

For use with most portable air tools, including grinders, drills, screwdrivers, buffers, sanders, staple guns, and more. Rotates 360° for awkward angles.

MODEL	INLET	WEIGHT	MAX PSI	TOOL CFM
7021	1/4" NPT	3 oz	Up to 125	25
7041A	3/8" NPT	11 oz	Up to 125	50
7051	1/2" NPT	7 oz	Up to 125	60

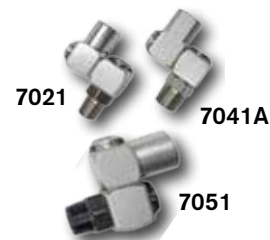

IN-LINE MINI REGULATORS

Easily adjust airflow with the turn of a dial.

MODEL	CAPACITY
932-100-0	1/8" NPT
932-110-0A	1/4" NPT



AIR LINE FITTINGS

MODEL	CAPACITY
250-RZ	1/4" NPT Rigid Fitting
250-SZ	1/4" NPT Swivel Fitting
375-RZ	3/8" NPT Rigid Fitting
375-SZ	3/8" NPT Swivel Fitting
500-SZ	1/2" NPT Swivel Fitting



MINI AIR GAUGE SWIVEL JOINT KITS

- Bi-directional 360° rotation
- Keeps air hose straight and untwisted
- Decreases operator fatigue



MODEL	INLET	WEIGHT	MAX PSI	TOOL CFM
7021AG	1/4" NPT	3 oz	Up to 125	25
7041AG	3/8" NPT	3 oz	Up to 125	50



7021AG

BRASS ADAPTERS AND BUSHINGS

Pipe fittings for use as medium and low pressure connectors. Meets functional requirements of SAE J530, SAE J531, ASME and ASA. Rated 1,000 PSI from -65° to +250° F.

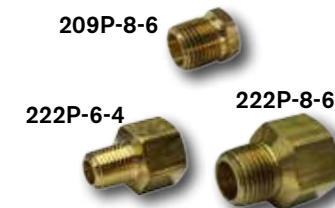

MODEL	DESCRIPTION
222P-6-4	3/8 NPT F x 1/4 NPT M Adapter
222P-8-6	1/2 NPT F x 3/8 NPT M Adapter
222P-12-8	3/4 NPT F x 1/2 NPT M Adapter
209P-6-4	1/4 NPT F x 3/8 NPT M Bushing
209P-8-6	3/8 NPT F x 1/2 NPT M Bushing

ERGONOMIC TWIST PLUGS

These unique, ergonomically designed hose fittings provide 360° rotation and 35° angled rotation in any direction.

- Two rotation points prevent kinking of air hose
- Design ensures full air pressure flow
- Rotating joint comes with polyurethane dust cover
- Heavy duty construction

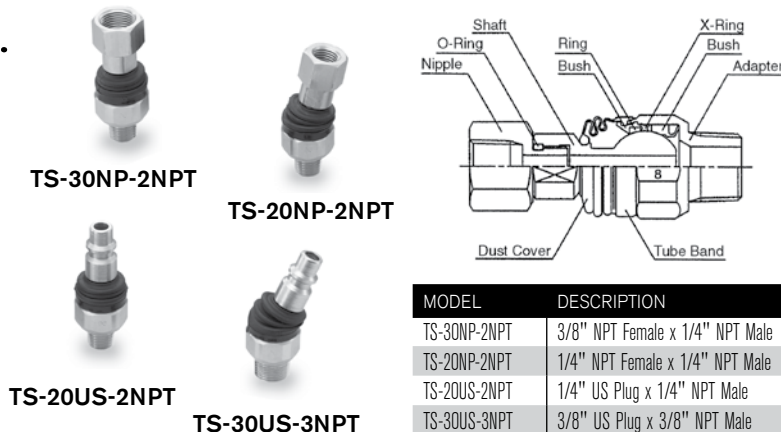

MODEL	DESCRIPTION
TS-30NP-2NPT	3/8" NPT Female x 1/4" NPT Male
TS-20NP-2NPT	1/4" NPT Female x 1/4" NPT Male
TS-20US-2NPT	1/4" US Plug x 1/4" NPT Male
TS-30US-3NPT	3/8" US Plug x 3/8" NPT Male

INDEX

MODEL #	PAGE	MODEL #	PAGE	MODEL #	PAGE	MODEL #	PAGE	MODEL #	PAGE
A									
AB-3	12	ACA-P2220-1500	10	AHB-3	12	F - H			
AB-3/5	12	ACA-P2220-2000	10	AHB-5	12	F70	8	TW-60	4
AB-5	12	ACA-P2220-2500	10	AIC3-2	12	F600	8	TW-70	4
ABT-3	12	ACA-POSIX	10	AIC5-2	12	F1500	8	W - Z	
ABT-5	12	ACA-V15-1000	10	AJH-3	12	F3000	8	WSCH	12
ABT5-R	12	ACA-V15-1500	10	AJH-5	12	F7500	8	Numbers	
ACA10-1000	10	ACA-V15-2000	10	AJS3	12	FA-50-2	13	209P-6-4	16
ACA10-1500	10	ACA-V40-1000	10	AMP-5	12	I			
ACA15-1000	10	ACA-V40-1500	10	ASB-0C	4	IP4	8	209P-8-6	16
ACA15-1500	10	ACA-V40-2000	10	ASB-3C	4	IP5	8	222P-6-4	16
ACA15-2000	10	ACA-V40-2500	10	ASB-5C	4	IP7	8	222P-8-6	16
ACA40-1000	10	ACA-V80-1500	10	ASC-3	12	IP8T	8	222P-12-8	16
ACA40-1500	10	ACA-V80-2000	10	ASC-5	12	IPT150	8	250-RZ	16
ACA40-2000	10	ACA-V80-2500	10	ASH-250C-10MSZ	15	IPT375	8	250-SZ	16
ACA40-2500	10	ACA-V150-1500	10	ASH-250C-15MSZ	15	J - K			
ACA40-2500	10	ACA-V150-2000	10	ASH-250C-25MSZ	15	JJ30	13	28178	14
ACA80-1500	10	ACA-V150-2500	10	ASH-375C-15MSZ	15	JJ30-S	13	28796	15
ACA80-2000	10	ACA-V220-1500	10	ASH-375C-25MSZ	15	JJ30-TA	13	375-RZ	16
ACA80-2500	10	ACA-V220-2000	10	ASH-375Z	15	L - Q			
ACA150-1500	10	ACA-V220-2500	10	ASH-500C-15MSZ	15	LQ-0002	7	375-SZ	16
ACA150-2000	10	ACPTT-V15-510 150	11	ASH-500C-25MSZ	15	LQ-0004	7	500-SZ	16
ACA150-2500	10	ACPTT-V15-710 300	11	ASH-500Z	15	LQ-0024H	7	7021	16
ACA220-1500	10	ACPTT-V40-510 150	11	AT3-3	12	LR-09B-90	5	7021AG	16
ACA220-2000	10	ACPTT-V40-760 300	11	AT3-4	12	LR-09B-200	5	7041A	16
ACA220-2500	10	ACPTT-V40-1410 600	11	AT3-6	12	R			
ACAH-15	11	ACPTT-V80-810 300	11	AT3-9	12	RMA-7L	5	7041AG	16
ACAH-15-MPE2745	11	ACPTT-V80-1410 600	11	AT5-3	12	RMA-15L	5	7051	16
ACAH-40-80	11	ACSA-600-1500	11	AT5-4	12	RMA-20L	5	932-100-0	16
ACAH-150-220	11	ACSA-800-1500	11	AT5-6	12	RPA-1	5	932-110-0A	16
ACAH-4080-MPE2745	11	ACSA-1000-1500	11	AT5-9	12	RPA-2	5		
ACAH-150220-MPE4070	11	ACTT-V15-600 150	11	AT5-12	12	RPA-3	5		
ACAH-S154080	11	ACTT-V15-800 300	11	ATN-3	12	S			
ACAH-SL15150	11	ACTT-V40-600 150	11	ATN-5	12	SH-5	12		
ACAHTT-15A-3060	11	ACTT-V40-850 300	11	ATW-50	13	T - V			
ACAHTT-15S-2745	11	ACTT-V40-1500 600	11	AUB-5	12	TA-50-2	13		
ACAHTT-40S-2745	11	ACTT-V80-900 300	11	AVC-5	12	TS-20NP-2NPT	16		
ACAHTT-4080A-3165	11	ACTT-V80-1500 600	11	AW3F	12	TS-20US-2NPT	16		
ACA-P2BK-4	11	ACTT-V80-2100 900	11	AW3FMF	13	TS-30NP-2NPT	16		
ACA-P2BK-6	11	AD-D1098-P	6	AW3FMS	13	TS-30US-3NPT	16		
ACA-P2BK-8	11	AD-D1098-PAC	6	AW3S	12	TW-00	4		
ACA-P2BK-10	11	AD-D1098-PACE	6	AW6F	12	TW-0	4		
ACA-P2BK-14	11	AD-D1098-S	6	AW6FMF	13	TW-3	4		
ACA-P215-1000	10	AD-D1098-SAC	6	AW6FMS	13	TW-5	4		
ACA-P215-1500	10	AEC5-2	12	AW6S	12	TW-9	4		
ACA-P215-2000	10	AEP-3	12	B - D				TW-15	4
ACA-P240-1000	10	AEP-5	12	B23	16	TW-22	4		
ACA-P240-1500	10	AES-3	12	B23E	16	TW-30	4		
ACA-P240-2000	10	AES-5	12	B25	16	TW-40	4		
ACA-P240-2500	10	AFRL-4	14	E				TW-50	4
ACA-P280-1500	10	AFRL-4HTA	14	EAA-04	7				
ACA-P280-2000	10	AFRL-2	14	EAP-202ASSY	7				
ACA-P280-2500	10	AFRL-2-C	14	EAP-202ED-KIT	7				
ACA-P2150-1500	10	AFRL-3	14	EAP-203-ASSY	7				
ACA-P2150-2000	10	AFRL-3-C	14						
ACA-P2150-2500	10	AFRL-8	14						

AIMCO CORPORATE HEADQUARTERS

10000 SE Pine Street
Portland, Oregon 97216
Phone: (503) 254-6600
Toll Free: 1-800-852-1368

AIMCO CORPORATION DE MEXICO SA DE CV

Ave. Cristobal Colon 14529
Chihuahua, Chihuahua. 31125
Phone: (01-614) 380-1010
Fax: (01-614) 380-1019

AIMCO SOUTH AMERICA

Carrera 29A, #7B-91.
Origami Building. Int604.
Medellin; Colombia 050021

AIMCO EUROPE

Dibao Plaza Avenida Río Gallo, 431
19174 Galápagos - Guadalajara
Spain
Phone: +34 673 34 99 25

AIMCO CHINA

Room 607, No. 3998 Hongxin Rd
Minhang District, Shanghai
China
Phone: 0086-21-34319246
Fax: 0086-21-34319245

