

COMMENTS	ITEM NO.	PART NUMBER	QTY.	DESCRIPTION
	1	UXR-1820(124T5)	1	HANDLE & MOTOR ASSY.
	2	195-867-9	1	GASKET
	3	27752	1	CLUTCH PINION ADAPTER, HT AIR TOOLS
	4	BB69032RS	1	BALL BEARING, DBL. SEAL, ABEC-1
	5	28300	1	CLUTCH ADAPTER HT AIR TOOLS
	6	28454	4	SCREW, BHSC, M6 X 20mm, STEEL
	7	28291	1	CLUTCH PLATE ASSY, HT AIR TOOLS
	8	28174	4	SPRING, COMPRESSION
	9	20105	4	DETENT BALL
	10	26488	1	O-RING, MOTOR HOUSING
	11	27744	1	CLUTCH DETENT PLATE
	12	24900	4	SCREW, SHC 6-32 X 1/2
	13	29149	1	GEARBOX ASSY, 348.053:1
	14	29285	6	SCREW, BHSC, TORX, 8-32 x .38, STEEL
	15	29374	1	LABEL, 2000Nm AIR TOOLS, 7000-SERIES
	16	26897	1	CHOOSE REACTION BAR
	17	26243	1	RETAINING RING, SPIRAL, Ø2.864 X Ø2.464 X .078
	18	29797	1	SAFETY LABEL, ISO M002/M003/M004
	19	29854	1	LABEL, YEAR OF MANUFACTURE

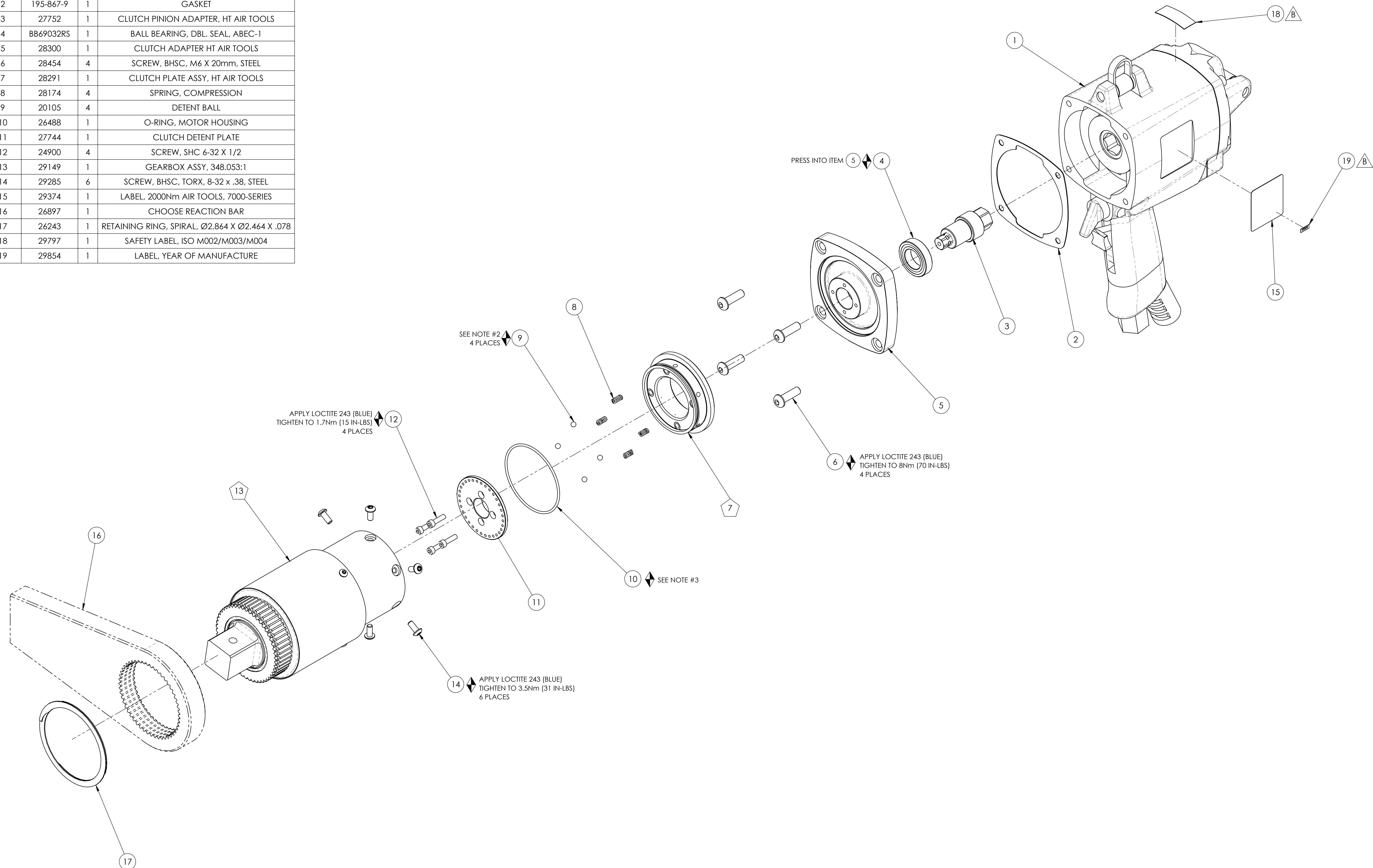

- ◆ ASSEMBLY INSTRUCTIONS
 - ◇ SUB-ASSEMBLY
- 1) GEARS & SPLINES: LUBRICATE WITH DOW CORNING MOLYKOTE BR2 PLUS GREASE.
 - 2) BEARINGS: LUBRICATE WITH CHEVRON SR1 GREASE
 - 3) O-RINGS: LUBRICATE WITH O-RING LUBE



DOCUMENT CONTROL
 PRINTED COPIES OF THIS DOCUMENT ARE CONSIDERED TO BE UNCONTROLLED DOCUMENTS. HOLDERS ARE RESPONSIBLE FOR VERIFYING THE CURRENT REVISION LEVEL WITH PURCHASING OR ENGINEERING PRIOR TO USE OR FABRICATION. THE CONTROLLED VERSION OF THIS DOCUMENT IS ELECTRONICALLY MAINTAINED.

PROPRIETARY AND CONFIDENTIAL
 THIS DRAWING CONTAINS INFORMATION STRICTLY CONFIDENTIAL TO ACRADYNE/AIMCO. IN THE ABSENCE OF EXPRESSED WRITTEN PERMISSION, ACRADYNE/AIMCO HAS LOANED THIS COPY WITH THE MUTUAL UNDERSTANDING THAT (A) IT WILL NOT BE USED FOR ANY PURPOSE OTHER THAN FOR THAT IN WHICH IT WAS PROVIDED, (B) THE DATA CONTAINED HEREIN WILL NOT BE DISCLOSED TO OTHERS, (C) IT WILL NOT BE REPRODUCED, AND (D) IT WILL BE RETURNED TO ACRADYNE/AIMCO IMMEDIATELY UPON DEMAND.

REVISION LEVEL	REVISION RELEASE DATE	DESCRIPTION OF CHANGES MADE TO PART	ECN #	AUTHOR/ APPROVAL

UNLESS OTHERWISE SPECIFIED, DIMENSIONS ARE IN INCHES
 DIMENSIONS AND TOLERANCING PER ANSI Y14.5
 SURFACE ROUGHNESS PER ANSI Y14.36

BLOCK TOLERANCING PER DECIMAL:
 .X = ±.030 .XX = ±.010 .XXX = ±.005 .XXXX = ±.0005
 ANGLE = ±0° 30'

REMOVE BURRS AND SHARP EDGES: R.015 MAX
 MACHINE SURFACE FINISH: 125 RMS OR BETTER

DRAWINGS AND TECHNICAL DOCUMENTS CONTROLLED BY:
ACRADYNE MECHANICAL ENGINEERING

HT AIR PISTOL NUTRUNNER
 7000 - SERIES

SIZE D	PART / DRAWING NUMBER AAP1B772000A	REVISION B
SCALE 2:3	DO NOT SCALE DRAWING	SHEET 1 OF 2

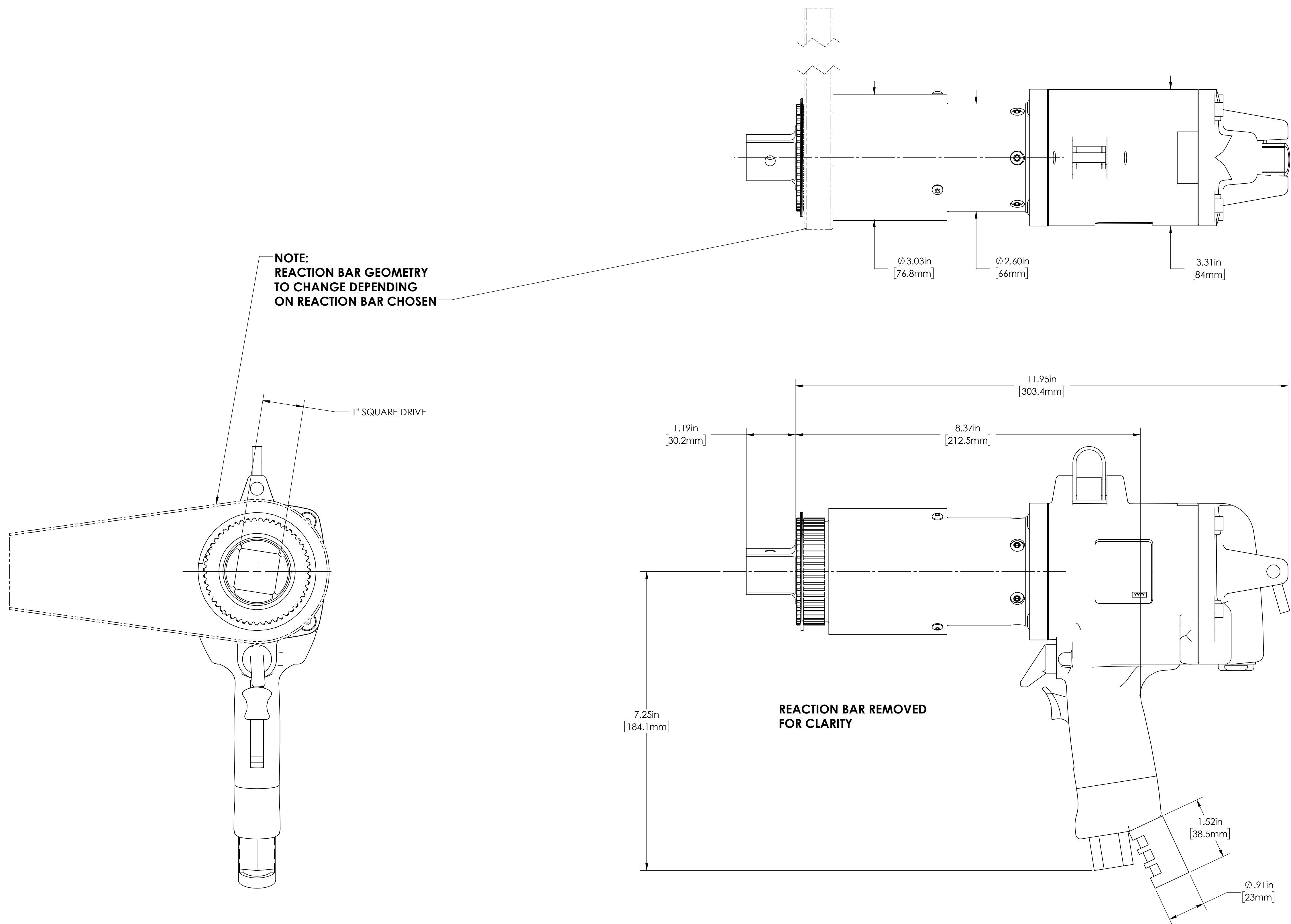

DOCUMENT CONTROL
PRINTED COPIES OF THIS DOCUMENT ARE CONSIDERED TO BE UNCONTROLLED DOCUMENTS. HOLDERS ARE RESPONSIBLE FOR VERIFYING THE CURRENT REVISION LEVEL WITH PURCHASING OR ENGINEERING PRIOR TO USE OR FABRICATION. THE CONTROLLED VERSION OF THIS DOCUMENT IS ELECTRONICALLY MAINTAINED.

PROPRIETARY AND CONFIDENTIAL
THIS DRAWING CONTAINS INFORMATION STRICTLY CONFIDENTIAL TO ACRADYNE/AIMCO. IN THE ABSENCE OF EXPRESSED WRITTEN PERMISSION, ACRADYNE/AIMCO HAS LOANED THIS COPY WITH THE MUTUAL UNDERSTANDING THAT (A) IT WILL NOT BE USED FOR ANY PURPOSE OTHER THAN FOR THAT IN WHICH IT WAS PROVIDED, (B) THE DATA CONTAINED HEREIN WILL NOT BE DISCLOSED TO OTHERS, (C) IT WILL NOT BE REPRODUCED, AND (D) IT WILL BE RETURNED TO ACRADYNE/AIMCO IMMEDIATELY UPON DEMAND.

REVISION LEVEL	REVISION RELEASE DATE	DESCRIPTION OF CHANGES MADE TO PART	ECN #	AUTHOR/ APPROVAL

UNLESS OTHERWISE SPECIFIED, DIMENSIONS ARE IN INCHES
DIMENSIONS AND TOLERANCING PER ANSI Y14.5
SURFACE ROUGHNESS PER ANSI Y14.36

BLOCK TOLERANCING PER DECIMAL:
X = ±.030 .XX = ±.010 .XXX = ±.005 .XXXX = ±.0005
ANGLE = ±0° 30'

REMOVE BURRS AND SHARP EDGES: R.015 MAX
MACHINE SURFACE FINISH: 125 RMS OR BETTER

HT AIR PISTOL NUTRUNNER
7000 - SERIES

SIZE	PART / DRAWING NUMBER	REVISION
D	AAP1B772000A	B
SCALE 3:4	DO NOT SCALE DRAWING	SHEET 2 OF 2

REVISION BLOCK

DRAWINGS AND TECHNICAL DOCUMENTS CONTROLLED BY:
ACRADYNE MECHANICAL ENGINEERING