

MODEL NO.	ANGLE HEAD G.C. ASM.
AEH32040C-1	27699
AEH32040C-2	27701

COMMENTS	ITEM NO.	PART NUMBER	QTY.	DESCRIPTION
	1	25426	1	MOTOR ASM., 7:1, 2000 SERIES GEN III
	2	25063	1	LED BOARD ASM.
	3	25075	2	SCREW, SHC 4-40X.375, STEEL, BLACK OXIDE
	4	25429	2	STAND-OFF, LED, 2000 SERIES
	5	27027	1	SCREW, SET 5-40X.188, STEEL, BLK OXIDE
	6	25104	1	RETAINING RING
	7	25103	1	PIN RETAINER RING
	8	25993	1	O-RING, RING GEAR TO MOTOR, GEN 3B 2000 SERIES
	9	SEE CHART	1	HOLD & DRIVE ANGLE HEAD G. C. ASM., 40Nm
	10	24272	2	ADAPTOR INSERT
	11	24324	2	DOWEL PIN 3/32 Dia x 7/8 LONG
	12	26102	1	TOOL CONNECTOR ASM., LEVER
	13	25745	5	SCREW, BHSC 4-40 STEEL, BLACK OXIDE
	14	25847	1	TID BOARD ASM.
	15	24934	2	SCREW, FHC 4-40 X .312, STEEL, BLACK OXIDE
	16	27030	1	HOUSING MOTOR/HANDLE ASSY
	17	20061	2	SCREW, LEVER
	18	26532	1	GEN 3 TRIGGER ASSY, CAST
	19	20132	1	THROTTLE SPRING
	20	25072	1	O-RING, LED LIGHT RING COVER
	21	20534	1	3000 SERIAL/MODEL LABEL
	22	25058	1	LIGHT RING COVER, LED
	23	26084	1	HANDLE COVER, MFB
	24	24679	1	RETAINING RING
	25	24683	1	SPRING, REV BUTTON
	26	24706	1	REV BUTTON SUB-ASSEMBLY
	27	26083	1	HANDLE COVER
	28	24940	10	SCREW, FHSC 4-40 X .25 LG., STEEL, BLACK OXIDE
	29	22141	1	SAFETY LABEL
	30	25796	1	O-RING, TRANSDUCER
SEE SHEET #3, COLUMN #3	31	26564	1	BIT HOLDER, 1/4" HEX
SEE SHEET #3, COLUMN #3	32	26565	1	BIT HOLDER, 5/16" HEX
SEE SHEET #3, COLUMNS #3 & #4	33	26557	1	TANG HOLDER
SEE SHEET #3, COLUMN #4	34	26640	1	1/4" HEX BIT
SEE SHEET #3, COLUMN #4	35	26645	1	5/16" HEX BIT
USE WITH ITEM #33 OR #34 ONLY	36	26571	1	SCREW, SET 8-32X.125, STEEL, BLACK OXIDE
SEE SHEET #3, COLUMNS #1 & #2	37	26554	1	HEX SOCKET, HOLD & DRIVE
	38	26555	2	DOWEL PIN, Ø1/8 X 7/16, ALLOY STEEL
	39	26556	2	SCREW, SET 10-32X.188, STEEL, BLACK OXIDE

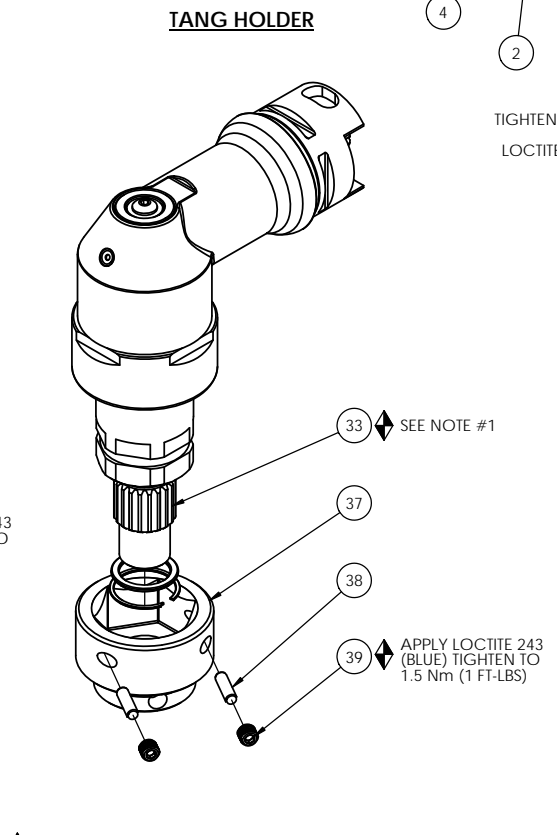
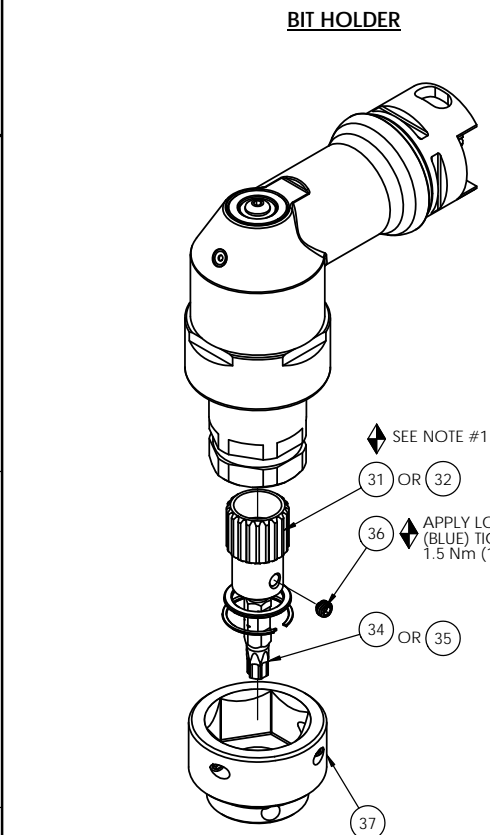

- ◆ ASSEMBLY INSTRUCTIONS
 - ◊ SUB-ASSEMBLY
- 1) GEARS & SPLINES: LUBRICATE WITH DOW CORNING MOLYKOTE BR2 PLUS GREASE.
 - 2) BEARINGS: LUBRICATE WITH CHEVRON SR1 GREASE
 - 3) O-RINGS: LUBRICATE WITH O-RING LUBE
 - 4) TIGHTEN TO 1 NM (9 IN-LBS.)
LOCTITE 243 (BLUE)

REQUIRED TOOLING
LOCTITE 243 (BLUE)
1/16 HEX WRENCH
5/64 HEX WRENCH
3/32 HEX WRENCH
SNAP RING PLIERS - EXTERNAL TYPE



DOCUMENT CONTROL
PRINTED COPIES OF THIS DOCUMENT ARE CONSIDERED TO BE UNCONTROLLED DOCUMENTS. HOLDERS ARE RESPONSIBLE FOR VERIFYING THE CURRENT REVISION LEVEL WITH PURCHASING OR ENGINEERING PRIOR TO USE OR FABRICATION. THE CONTROLLED VERSION OF THIS DOCUMENT IS ELECTRONICALLY MAINTAINED.

PROPRIETARY AND CONFIDENTIAL
THIS DRAWING CONTAINS INFORMATION STRICTLY CONFIDENTIAL TO ACRADYNE/AIMCO. IN THE ABSENCE OF EXPRESSED WRITTEN PERMISSION, ACRADYNE/AIMCO HAS LOANED THIS COPY WITH THE MUTUAL UNDERSTANDING THAT (A) IT WILL NOT BE USED FOR ANY PURPOSE OTHER THAN FOR THAT IN WHICH IT WAS PROVIDED, (B) THE DATA CONTAINED HEREIN WILL NOT BE DISCLOSED TO OTHERS, (C) IT WILL NOT BE REPRODUCED, AND (D) IT WILL BE RETURNED TO ACRADYNE/AIMCO IMMEDIATELY UPON DEMAND.

REVISION LEVEL	REVISION RELEASE DATE	DESCRIPTION OF CHANGES MADE TO PART	ECN #	AUTHOR/ APPROVAL

UNLESS OTHERWISE SPECIFIED, DIMENSIONS ARE IN INCHES
DIMENSIONS AND TOLERANCING PER ANSI Y14.5 SURFACE ROUGHNESS PER ANSI Y14.36

BLOCK TOLERANCING PER DECIMAL:
.X = ±.030 .XX = ±.010 .XXX = ±.005 .XXXX = ±.0005
ANGLE = ±0°30'

REMOVE BURRS AND SHARP EDGES: R.015 MAX MACHINE SURFACE FINISH: 125 RMS OR BETTER

DRAWINGS AND TECHNICAL DOCUMENTS CONTROLLED BY:
ACRADYNE MECHANICAL ENGINEERING

AEH32040C- HOLD & DRIVE NUTRUNNER 2000 SERIES, GEN 3C	
SIZE D	PART / DRAWING NUMBER AEH32040C- B
SCALE 1:1	DO NOT SCALE DRAWING
SHEET 1 OF 3	REVISION B

BASE MODEL	DOT	SOCKET BASE	COLUMN 1	SOCKET SIZE	COLUMN 2	HOLDER BASE	COLUMN 3	HOLDER SIZE	COLUMN 4
AEH32040C-	.	X	SOCKET TYPE & EXTENSION	X	HEX SIZE	X	TANG/BIT HOLDER & EXTENSION	X	SIZE
							BIT HOLDER		
	A		26554-1 SINGLE HEX (NO EXTENSION)	A	14mm	A	26564-1 (1/4" BIT)(NO EXTENSION)	A	4mm
	B		26554-2 SINGLE HEX (3mm EXTENDED)	B	15mm	B	26564-2 (1/4" BIT)(3mm EXTENDED)	B	5mm
	C		26554-3 SINGLE HEX (9mm EXTENDED)	C	16mm	C	26564-3 (1/4" BIT)(9mm EXTENDED)	C	6mm
	D		26554-4 SINGLE HEX (12mm EXTENDED)	D	17mm	D	26564-4 (1/4" BIT)(12mm EXTENDED)	D	7mm
	E		26554-5 SINGLE HEX (24mm EXTENDED)	E	18mm	E	26564-5 (1/4" BIT)(24mm EXTENDED)	E	8mm
				F	19mm			F	9mm
	F		26554-1 SURFACE DRIVE (NO EXTENSION)	G	20mm	F	26565-1 (5/16" BIT)(NO EXTENSION)	G	10mm
	G		26554-2 SURFACE DRIVE (3mm EXTENDED)	H	21mm	G	26565-2 (5/16" BIT)(3mm EXTENDED)	H	3/16"
	H		26554-3 SURFACE DRIVE (9mm EXTENDED)	I	9/16"	H	26565-3 (5/16" BIT)(9mm EXTENDED)	I	1/4"
	J		26554-4 SURFACE DRIVE (12mm EXTENDED)	J	5/8"	I	26565-4 (5/16" BIT)(12mm EXTENDED)	J	5/16"
	K		26554-5 SURFACE DRIVE (24mm EXTENDED)	K	11/16"	J	26565-5 (5/16" BIT)(24mm EXTENDED)	K	3/8"
				L	3/4"		FEMALE TANG HOLDER	L	T15
	L		26554-1 DOUBLE HEX (NO EXTENSION)	M	13/16"	K	26557-1 HEX (NO EXTENSION)	M	T20
	M		26554-2 DOUBLE HEX (3mm EXTENDED)	N		L	26557-2 HEX (3mm EXTENDED)	N	T25
	N		26554-3 DOUBLE HEX (9mm EXTENDED)	O		M	26557-3 HEX (9mm EXTENDED)	O	T30
	P		26554-4 DOUBLE HEX (12mm EXTENDED)	P		N	26557-4 HEX (12mm EXTENDED)	P	T40
	Q		26554-5 DOUBLE HEX (24mm EXTENDED)	Q		P	26557-5 HEX (24mm EXTENDED)	Q	T45
				R				R	T50
				S		Q	26557-1 TORX (NO EXTENSION)	S	E8
				T		R	26557-2 TORX (3mm EXTENDED)	T	E10
				U		S	26557-3 TORX (9mm EXTENDED)	U	E11
				V		T	26557-4 TORX (12mm EXTENDED)	V	E12
				W		U	26557-5 TORX (24mm EXTENDED)		
				X					
				Y		V	26557-1 D-TYPE (NO EXTENSION)	W	4 x 6
				Z		W	26557-2 D-TYPE (3mm EXTENDED)	X	5 x 8
						X	26557-3 D-TYPE (9mm EXTENDED)	Y	6 x 8
						Y	26557-4 D-TYPE (12mm EXTENDED)	Z	6.4 x 8
						Z	26557-5 D-TYPE (24mm EXTENDED)	1	TBD

****EXAMPLE MODEL NUMBER:** AEH32040C-1.CDCJ = 1" TRAVEL, SINGLE HEX EXT. 9mm, 17mm HEX, 1/4" BIT HOLDER EXT. 9mm WITH 5/16" HEX BIT

 <p>10000 SE PINE STREET PORTLAND, OREGON 97216 503.254.6600</p>	<p>DOCUMENT CONTROL PRINTED COPIES OF THIS DOCUMENT ARE CONSIDERED TO BE UNCONTROLLED DOCUMENTS. HOLDERS ARE RESPONSIBLE FOR VERIFYING THE CURRENT REVISION LEVEL WITH PURCHASING OR ENGINEERING PRIOR TO USE OR FABRICATION. THE CONTROLLED VERSION OF THIS DOCUMENT IS ELECTRONICALLY MAINTAINED.</p>						<p>UNLESS OTHERWISE SPECIFIED, DIMENSIONS ARE IN INCHES DIMENSIONS AND TOLERANCING PER ANSI Y14.5 SURFACE ROUGHNESS PER ANSI Y14.36</p> <p>BLOCK TOLERANCING PER DECIMAL: .X = ±.030 .XX = ±.010 .XXX = ±.005 .XXXX = ±.0005 ANGLE = ±0° 30'</p> <p>REMOVE BURRS AND SHARP EDGES: R.015 MAX MACHINE SURFACE FINISH: 125 RMS OR BETTER</p> <p>DRAWINGS AND TECHNICAL DOCUMENTS CONTROLLED BY: ACRADYNE MECHANICAL ENGINEERING</p>	<p>AEH32040C-_- HOLD & DRIVE NUTRUNNER 2000 SERIES, GEN 3C</p>											
	<p>PROPRIETARY AND CONFIDENTIAL THIS DRAWING CONTAINS INFORMATION STRICTLY CONFIDENTIAL TO ACRADYNE/AIMCO. IN THE ABSENCE OF EXPRESSED WRITTEN PERMISSION, ACRADYNE/AIMCO HAS LOANED THIS COPY WITH THE MUTUAL UNDERSTANDING THAT (A) IT WILL NOT BE USED FOR ANY PURPOSE OTHER THAN FOR THAT IN WHICH IT WAS PROVIDED, (B) THE DATA CONTAINED HEREIN WILL NOT BE DISCLOSED TO OTHERS, (C) IT WILL NOT BE REPRODUCED, AND (D) IT WILL BE RETURNED TO ACRADYNE/AIMCO IMMEDIATELY UPON DEMAND.</p>	<table border="1"> <tr> <th>REVISION LEVEL</th> <th>REVISION RELEASE DATE</th> <th>DESCRIPTION OF CHANGES MADE TO PART</th> <th>ECN #</th> <th>AUTHOR/ APPROVAL</th> </tr> <tr> <td> </td> <td> </td> <td> </td> <td> </td> <td> </td> </tr> </table>	REVISION LEVEL	REVISION RELEASE DATE	DESCRIPTION OF CHANGES MADE TO PART	ECN #		AUTHOR/ APPROVAL						<table border="1"> <tr> <td>SIZE</td> <td>PART / DRAWING NUMBER</td> <td>REVISION</td> </tr> <tr> <td>B</td> <td>AEH32040C-_-</td> <td>B</td> </tr> </table>	SIZE	PART / DRAWING NUMBER	REVISION	B	AEH32040C-_-
REVISION LEVEL	REVISION RELEASE DATE	DESCRIPTION OF CHANGES MADE TO PART	ECN #	AUTHOR/ APPROVAL															
SIZE	PART / DRAWING NUMBER	REVISION																	
B	AEH32040C-_-	B																	

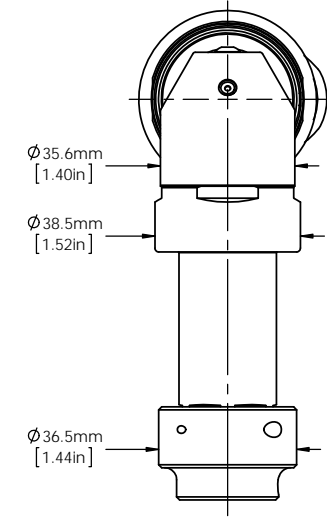
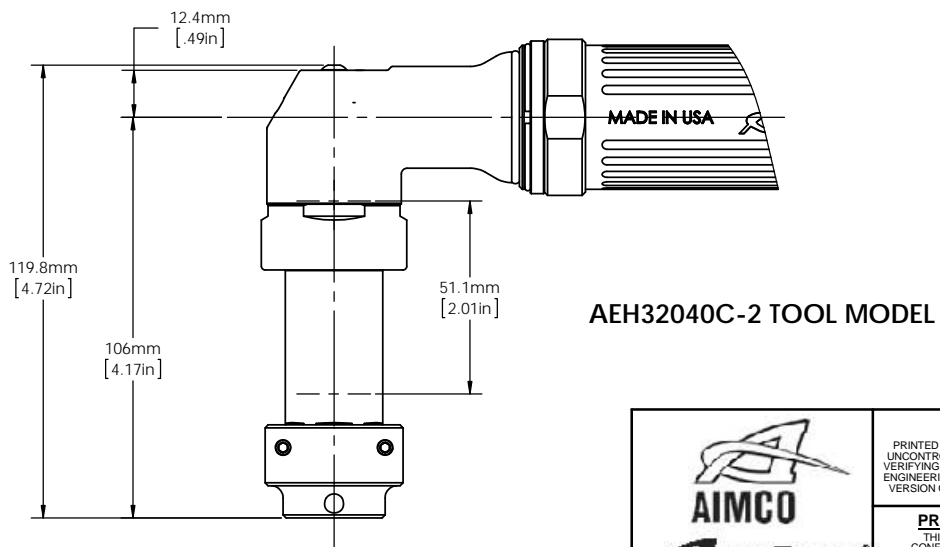
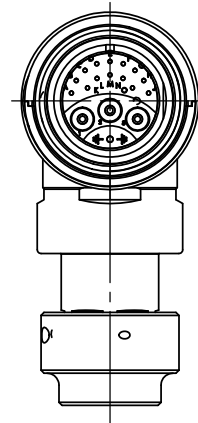
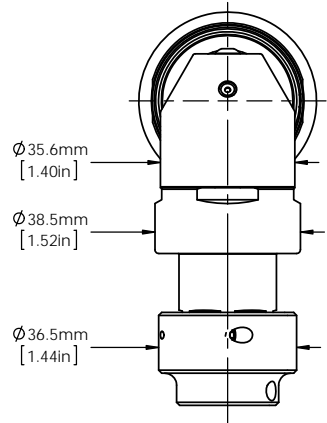
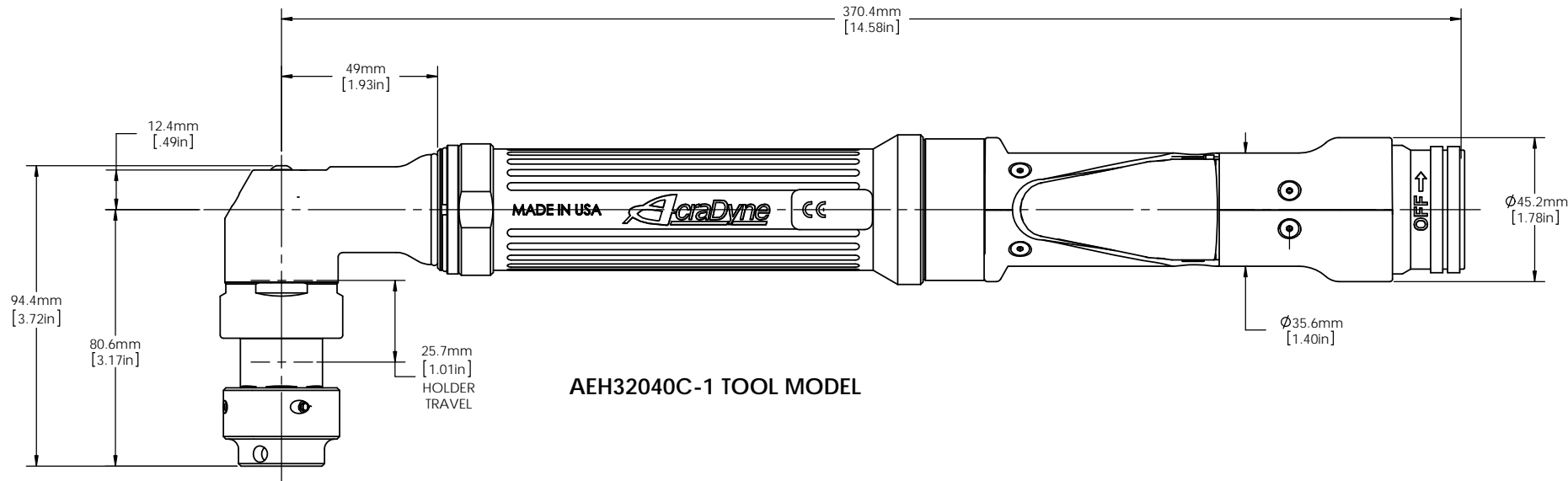
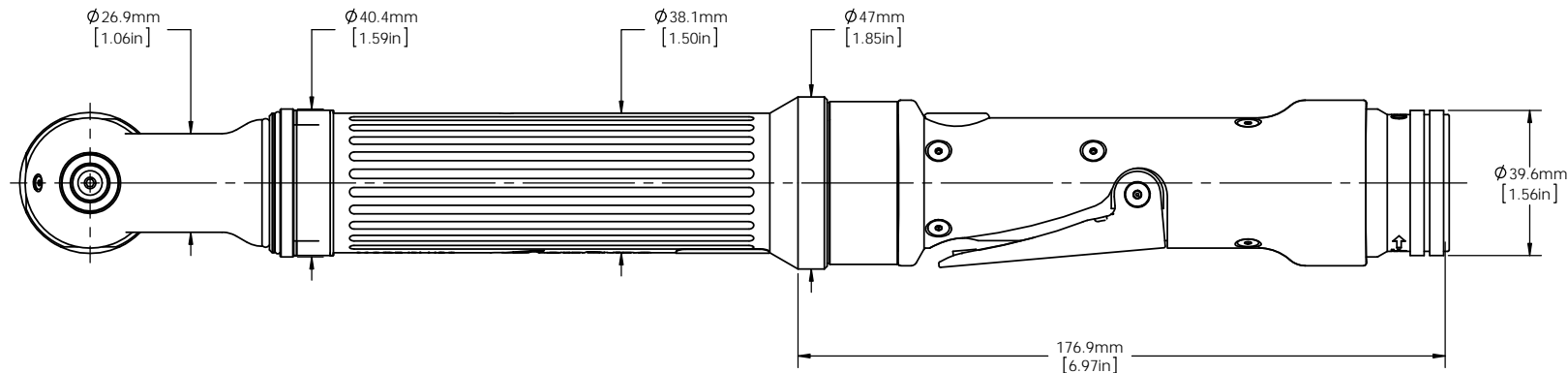

DOCUMENT CONTROL
 PRINTED COPIES OF THIS DOCUMENT ARE CONSIDERED TO BE UNCONTROLLED DOCUMENTS. HOLDERS ARE RESPONSIBLE FOR VERIFYING THE CURRENT REVISION LEVEL WITH PURCHASING OR ENGINEERING PRIOR TO USE OR FABRICATION. THE CONTROLLED VERSION OF THIS DOCUMENT IS ELECTRONICALLY MAINTAINED.

PROPRIETARY AND CONFIDENTIAL
 THIS DRAWING CONTAINS INFORMATION STRICTLY CONFIDENTIAL TO ACRADYNE/AIMCO. IN THE ABSENCE OF EXPRESSED WRITTEN PERMISSION, ACRADYNE/AIMCO HAS LOANED THIS COPY WITH THE MUTUAL UNDERSTANDING THAT (A) IT WILL NOT BE USED FOR ANY PURPOSE OTHER THAN FOR THAT IN WHICH IT WAS PROVIDED, (B) THE DATA CONTAINED HEREIN WILL NOT BE DISCLOSED TO OTHERS, (C) IT WILL NOT BE REPRODUCED, AND (D) IT WILL BE RETURNED TO ACRADYNE/AIMCO IMMEDIATELY UPON DEMAND.

REVISION LEVEL	REVISION RELEASE DATE	DESCRIPTION OF CHANGES MADE TO PART	ECN #	AUTHOR/ APPROVAL

REVISION BLOCK

UNLESS OTHERWISE SPECIFIED, DIMENSIONS ARE IN INCHES
 DIMENSIONS AND TOLERANCING PER ANSI Y14.5
 SURFACE ROUGHNESS PER ANSI Y14.36

BLOCK TOLERANCING PER DECIMAL:
 .X = ±.030 .XX = ±.010 .XXX = ±.005 .XXXX = ±.0005
 ANGLE = ±0° 30'

REMOVE BURRS AND SHARP EDGES: R.015 MAX
 MACHINE SURFACE FINISH: 125 RMS OR BETTER

DRAWINGS AND TECHNICAL DOCUMENTS CONTROLLED BY:
ACRADYNE MECHANICAL ENGINEERING

AEH32040C- HOLD & DRIVE NUTRUNNER TOOL OUTLINE 2000 SERIES, GEN 3C		
SIZE	PART / DRAWING NUMBER	REVISION
D	AEH32040C-<u> </u>	B
SCALE 1:1	DO NOT SCALE DRAWING	SHEET 2 OF 3