

COMMENTS	ITEM NO.	PART NUMBER	QTY.	DESCRIPTION
	1	26058	1	MOTOR ASM., 5000 SERIES
	2	26082	1	LEVER HANDLE
	3	26198	1	THRUST WASHER
	4	26074	1	BELLEVILLE WASHER
	5	26530	2	DOWEL PIN, Ø1/8 x 1.00, STEEL
	6	28138	1	GEAR TRAIN ASM. (18.38:1), HT ANGLE TOOLS, 540 & 1600Nm
	7	20912	1	WAVE SPRING --- 3000 SERIES
	8	26117	1	ASSEMBLY, GEAR CARRIER, 2ND STAGE
	9	20911	2	BELLEVILLE WASHER
	10	27637	1	ANGLEHEAD ASM., HT ANGLEHEAD, 540 Nm, 6000-SERIES
	11	20913	2	PIN, RETAINING
	12	27391	1	PIN RETAINER RING
	13	26077	2	M-F THREADED HEX STANDOFF
	14	26095	1	LED BOARD ASM.
	15	26078	2	SHC SCREW, 4-40, BLACK OXIDE
	16	26102	1	TOOL CONNECTOR ASM., LEVER
	17	25102	1	SCREW, BHC 4-40X.188, STEEL, BLACK OXIDE
	18	25847	1	TID BOARD ASM.
	19	24934	2	SCREW, FHC 4-40 X .312, STEEL, BLACK OXIDE
	20	20132	1	THROTTLE SPRING
	21	26532	1	GEN 3 TRIGGER ASSY, CAST
	22	20061	2	SCREW, LEVER
	23	26080	1	O-RING, LED LIGHT RING COVER
	24	20534	1	3000 SERIAL/MODEL LABEL
	25	26079	1	LIGHT RING COVER, LED
	26	26084	1	HANDLE COVER, MFB
	27	24706	1	REV BUTTON SUB-ASSEMBLY
	28	24683	1	SPRING, REV BUTTON
	29	24679	1	RETAINING RING
	30	24940	10	SCREW, FHSC 4-40 X .25 LG., STEEL, BLACK OXIDE
	31	26083	1	HANDLE COVER
	32	22141	1	SAFETY LABEL
	33	25745	6	SCREW, BHSC 4-40 STEEL, BLACK OXIDE
	34	25457	2	SCREW, BHSC 4-40, STEEL, BLACK OXIDE
	35	26081	2	MOTOR HOUSING COVER
	36	25385	8	SCREW, FHSC 6-32 X .375, STEEL
	37	26088	6	SCREW, BHC 8-32X.25, STEEL, BLACK OXIDE
	38	27636	1	GEARBOX ASSY, HT ANGLEHEAD, 500 Nm
	39	27640	1	RETAINER, HT ANGLE TOOLS
	40	26488	1	O-RING, MOTOR HOUSING
	41	27672	1	GEAR CASE COVER 500 NM, HT ANGLE TOOL
	42	26319	3	SCREW, BHSC 6-32 X .188, 18-8 SS
	43	27671	1	WIREWAY 500 NM & 1600 NM
	44	27670	1	WIREWAY MOUNTING BLOCK 500 NM
	45	26896	1	CHOOSE REACTION BAR
	46	26514	1	RETAINING RING, SPIRAL, Ø2.441 X Ø2.105 X .078

REQUIRED TOOLING
LOCTITE 243 (BLUE)
1/16 HEX WRENCH
5/64 HEX WRENCH
3/32 HEX WRENCH
7/32 HEX WRENCH
SNAP RING PLIERS - EXTERNAL TYPE

- ◆ ASSEMBLY INSTRUCTIONS
  - ◊ SUB-ASSEMBLY
- 1) GEARS & SPLINES: LUBRICATE WITH DOW CORNING MOLYKOTE BR2 PLUS GREASE.
  - 2) BEARINGS: LUBRICATE WITH CHEVRON SR1 GREASE
  - 3) O-RINGS: LUBRICATE WITH O-RING LUBE
  - 4) APPLY LOCTITE 243 (BLUE), TIGHTEN TO 1.0 Nm (9 IN-LBS)



**DOCUMENT CONTROL**  
 PRINTED COPIES OF THIS DOCUMENT ARE CONSIDERED TO BE UNCONTROLLED DOCUMENTS. HOLDERS ARE RESPONSIBLE FOR VERIFYING THE CURRENT REVISION LEVEL WITH PURCHASING OR ENGINEERING PRIOR TO USE OR FABRICATION. THE CONTROLLED VERSION OF THIS DOCUMENT IS ELECTRONICALLY MAINTAINED.

**PROPRIETARY AND CONFIDENTIAL**  
 THIS DRAWING CONTAINS INFORMATION STRICTLY CONFIDENTIAL TO ACRADYNE/AIMCO. IN THE ABSENCE OF EXPRESSED WRITTEN PERMISSION, ACRADYNE/AIMCO HAS LOANED THIS COPY WITH THE MUTUAL UNDERSTANDING THAT (A) IT WILL NOT BE USED FOR ANY PURPOSE OTHER THAN FOR THAT IN WHICH IT WAS PROVIDED, (B) THE DATA CONTAINED HEREIN WILL NOT BE DISCLOSED TO OTHERS, (C) IT WILL NOT BE REPRODUCED, AND (D) IT WILL BE RETURNED TO ACRADYNE/AIMCO IMMEDIATELY UPON DEMAND.

REVISION LEVEL	REVISION RELEASE DATE	DESCRIPTION OF CHANGES MADE TO PART	ECN #	AUTHOR/ APPROVAL

**REVISION BLOCK**

**UNLESS OTHERWISE SPECIFIED, DIMENSIONS ARE IN INCHES**  
 DIMENSIONS AND TOLERANCING PER ANSI Y14.5 SURFACE ROUGHNESS PER ANSI Y14.36

**BLOCK TOLERANCING PER DECIMAL:**  
 .X = ±.030 .XX = ±.010 .XXX = ±.005 .XXXX = ±.0005  
 ANGLE = 40°/30°

REMOVE BURRS AND SHARP EDGES: R.015 MAX MACHINE SURFACE FINISH: 125 RMS OR BETTER

DRAWINGS AND TECHNICAL DOCUMENTS CONTROLLED BY:  
**ACRADYNE MECHANICAL ENGINEERING**

<b>AEN356540A HT ANGLE NUTRUNNER 5000-SERIES</b>		
SIZE <b>D</b>	PART / DRAWING NUMBER <b>AEN356540A</b>	REVISION <b>B</b>
SCALE 1:8	DO NOT SCALE DRAWING	SHEET 1 OF 2

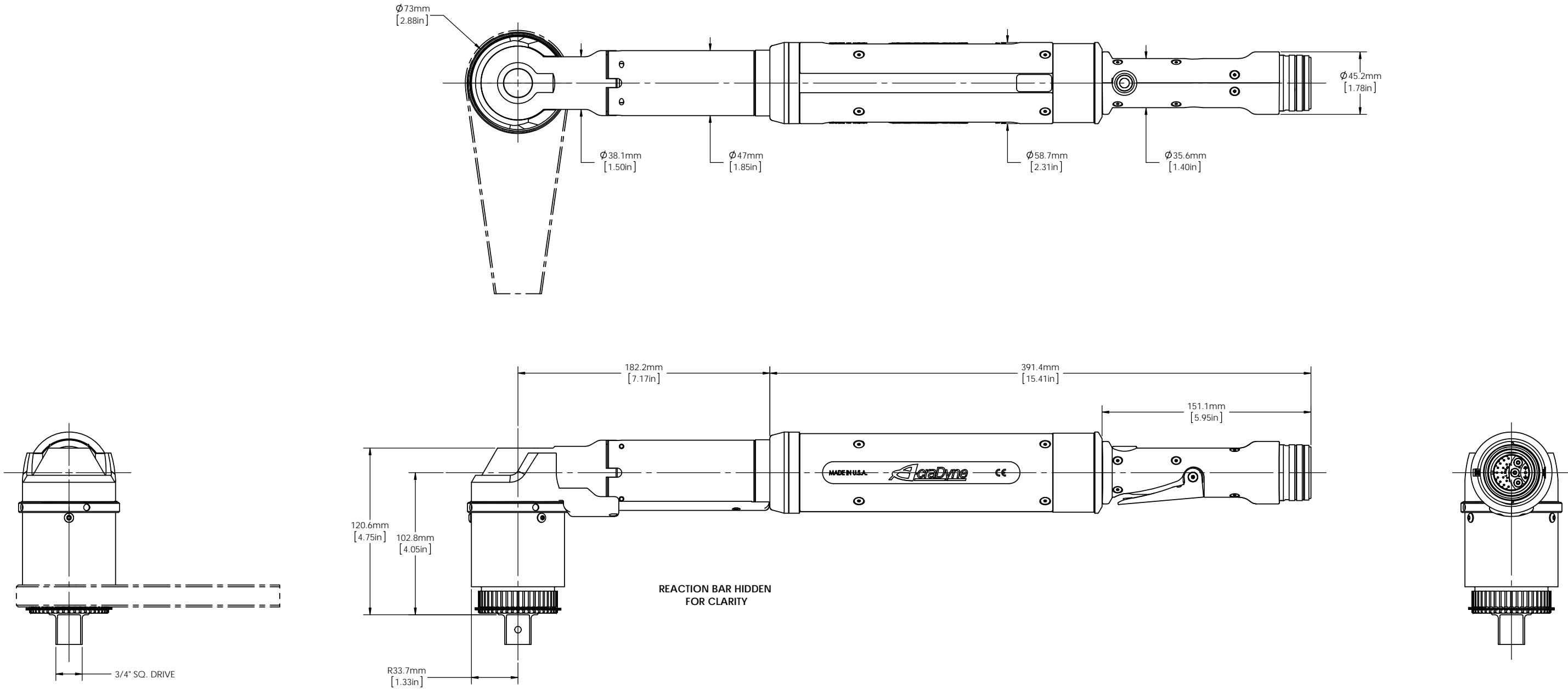

**DOCUMENT CONTROL**  
 PRINTED COPIES OF THIS DOCUMENT ARE CONSIDERED TO BE UNCONTROLLED DOCUMENTS. HOLDERS ARE RESPONSIBLE FOR VERIFYING THE CURRENT REVISION LEVEL WITH PURCHASING OR ENGINEERING PRIOR TO USE OR FABRICATION. THE CONTROLLED VERSION OF THIS DOCUMENT IS ELECTRONICALLY MAINTAINED.

**PROPRIETARY AND CONFIDENTIAL**  
 THIS DRAWING CONTAINS INFORMATION STRICTLY CONFIDENTIAL TO ACRADYNE/AIMCO. IN THE ABSENCE OF EXPRESSED WRITTEN PERMISSION, ACRADYNE/AIMCO HAS LOANED THIS COPY WITH THE MUTUAL UNDERSTANDING THAT (A) IT WILL NOT BE USED FOR ANY PURPOSE OTHER THAN FOR THAT IN WHICH IT WAS PROVIDED, (B) THE DATA CONTAINED HEREIN WILL NOT BE DISCLOSED TO OTHERS, (C) IT WILL NOT BE REPRODUCED, AND (D) IT WILL BE RETURNED TO ACRADYNE/AIMCO IMMEDIATELY UPON DEMAND.

REVISION LEVEL	REVISION RELEASE DATE	DESCRIPTION OF CHANGES MADE TO PART	ECN #	AUTHOR/ APPROVAL

**UNLESS OTHERWISE SPECIFIED, DIMENSIONS ARE IN INCHES**  
 DIMENSIONS AND TOLERANCING PER ANSI Y14.5  
 SURFACE ROUGHNESS PER ANSI Y14.36

**BLOCK TOLERANCING PER DECIMAL:**  
 .X = ±.030 .XX = ±.010 .XXX = ±.005 .XXXX = ±.0005  
 ANGLE = ±0° 30'

REMOVE BURRS AND SHARP EDGES: R.015 MAX  
 MACHINE SURFACE FINISH: 125 RMS OR BETTER

**DRAWINGS AND TECHNICAL DOCUMENTS CONTROLLED BY:**  
 ACRADYNE MECHANICAL ENGINEERING

<b>AEN356540A</b> HT ANGLE NUTRUNNER 5000-SERIES		
SIZE <b>D</b>	PART / DRAWING NUMBER <b>AEN356540A</b>	REVISION <b>B</b>
SCALE 2:3	DO NOT SCALE DRAWING	SHEET 2 OF 2