



SOCKET TRAYS

2-, 4-, 6-, or 8-Position Operation Manual



PO Box 16460, Portland OR 97292-0460 • 800-852-1368 • Fax 800-582-9015

www.aimco-global.com

Description



Model #AMPST-2-I
#AMPST-2-U



Model #AMPST-4-I
#AMPST-4-U



Model #AMPST-6-I
#AMPST-6-U
#AMPST-6S-I
#AMPST-6S-U



Model #AMPST-8-I
#AMPST-8-IL
#AMPST-8-U

The AIMCO Socket Tray is an accessory used in conjunction with AcraDyne™ and URYU controlled Nutrunning equipment. The AIMCO Socket Tray allows the user to associate a specific socket position with a particular control strategy.

The AIMCO Socket Trays also provide an Inhibit function that disables the operator's tool when more than one Socket/Test pin is removed from the tray or if all Sockets/Test Pins are in place.

AIMCO provides Socket Trays in 2-, 4-, 6-, and 8-position configurations:

AMPST-2-I 2-Position AIMCO Socket Tray for IEC Controller
AMPST-2-U 2-Position AIMCO Socket Tray for UEC Controller

AMPST-4-I 4-Position AIMCO Socket Tray for IEC Controller
AMPST-4-U 4-Position AIMCO Socket Tray for UEC Controller
AMPST-6-I 6-Position AIMCO Socket Tray for IEC Controller
AMPST-6-U 6-Position AIMCO Socket Tray for UEC Controller
AMPST-6S-I 6-Position AIMCO Socket Tray for ??
AMPST-6S-U 6-Position AIMCO Socket Tray for ??
AMPST-8-I 8-Position AIMCO Socket Tray for IEC Controller
AMPST-8-IL 8-Position AIMCO Socket Tray for ??
AMPST-8-U 6-Position AIMCO Socket Tray for UEC Controller

The AIMCO Socket Tray comes with generic Delrin® Socket Holders pre-installed. The Socket Holder must be bored to accommodate the desired Socket to be used in the specific position.

Operational Notes

The AIMCO socket tray is designed to assist in the proper selection of parameter sets (also known as applications, p-sets, or selects). This is accomplished through the use of proximity sensors mounted in such a way as to sense the presence of a socket in close proximity.

The system is designed to ensure that the controller will allow the assembly tool to operate when one, and only one, socket has been pulled from the socket tray, so that all but one socket is still present in the tray.

If any other condition exists (more than one socket pulled or all sockets in position) then the socket tray will send a signal or combination of signals to alert the controller of a socket error condition. This is achieved in one of two ways, depending on the configuration of the socket tray dip switches, located on the circuit board inside the socket tray:

1. A digital signal is turned on to enable or disable the tool (brand-specific).

2. A series of digital signals is turned on to select an "unused" parameter set. For tool controllers which do not allow for a remote enable or disable, the strategy is to activate a parameter set which is unprogrammed, which will affectively disable the tool through the controller.

It is the responsibility of the end-user to ensure the following:

1. The socket tray pucks have been machined in such a way that sockets can fit only in one particular socket tray position.
2. The actual socket to be used for a given application has been appropriately tied to a particular application.
3. The software and system configurations necessary to allow successful communication between the socket tray and the tool controller have been properly set.

System Setup

Socket Tray Setup

It is the responsibility of the end-user to ensure the following:

- The socket tray pucks have been machined in such a way that sockets can fit only in one particular socket tray position.
- The actual socket to be used for a given application has been appropriately tied to a particular application.
- The software and system configurations necessary to allow successful communication between the socket tray and the tool controller have been properly set.

Connections

Connect the 10-pin cable provided to connector shown and to the controller IO connector.



Precautionary Measures

Every brand and series of tool controller has unique operational features. It is important that the user be familiar with these features, and be vigilant in planning for lost communication/socket tray failure. For instance, with some brands/series of controllers, the controller will default to parameter set 1 when no inputs are received from the socket tray. In this scenario, it is possible that if the socket tray lost power, the operator could unknowingly pull sockets and assemble products with the controller continually set to parameter set 1. It is therefore recommended that these scenarios be considered prior to operation of the socket tray to ensure proper use of the programmed parameters. In the scenario described above, it would be prudent to leave parameter set 1 “empty,” which would prevent the tool from running in the absence of a socket tray input.

Customizing Your Socket Tray

To customize the AIMCO Socket Tray locations to your sockets, perform the following operations:

DO NOT MODIFY HOLDERS WHEN THEY ARE MOUNTED IN THE ENCLOSURE.

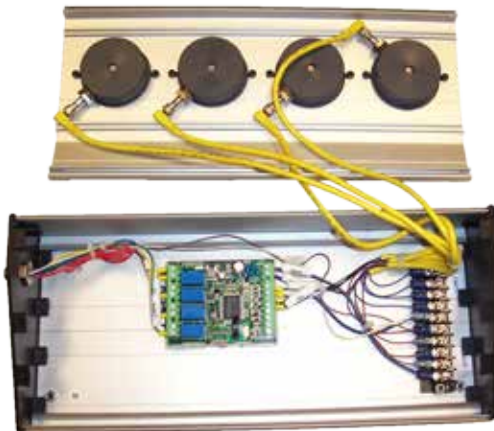

1. Remove the top (2) two Philips screws on each end of the enclosure that hold the black end caps on the enclosure.
2. Pop the top cover off and lay the plate face down behind the enclosure (see photo above. Four-position socket tray shown as an example).
3. Unscrew the sensor cables from the sensors and unscrew the sensors from the individual Delrin socket holders.
4. Unscrew the two (2) socket head cap screws and remove the desired socket holders from the plate.
5. Remove the test pin(s) from the Delrin holder(s).

6. Using a bore or lathe, increase the diameter of the holder to match the OD of the socket. The bore must be 0.95”–1.0” deep, which should be just below the threaded hole for the sensor.
7. Replace the socket holder(s) into the top plate and secure with two (2) socket head cap screws.
8. Re-install the sensor into the socket holder(s). The sensor should be screwed in just far enough to reach the edge of the sidewall, but still allow the socket to seat fully into the holder without impacting the sensor.
9. Attach the corresponding cables to the sensor(s) according to the position number. Position One (1) is always on the left.
10. Test
 - a. Plug the unit in to the power supply.
 - b. Insert sockets or test pins into each socket holder.
 - c. Remove one socket/test pin at a time and check to see if yellow LED changes from a bright illumination to dim.

When sensors are powered without a socket/pin present, the yellow LEDs will be dim. When a metal socket is present, the yellow LEDs will be bright.

11. Place the top plate on to the enclosure, being careful to tuck the cables neatly back inside.
12. Replace the top two (2) Philips screws on each end of the enclosure that hold the black end caps to complete the procedure.
13. Hook up the cable to the controller and retest to insure that the cable is communicating with the controller. (Program the controller individual parameter sets according to the parameter section of the controller’s manual).

Connecting Your AIMCO Socket Tray

Connecting the AIMCO Socket Tray to varied controllers is simple.

Necessary Accessories

013-13-IEC	Cable/Power Supply for AcraDyne™ IEC Controllers
013-13-EV	Cable/Power Supply for AcraDyne™ Evolution Controllers
013-13-45	Cable/Power Supply for Uryu UEC-4500 Controllers
013-13-48	Cable/Power Supply for Uryu UEC-4800 Controllers
MME-44ZES-D024	Normally Open Solenoid Valve for 1/4" NPT pneumatic tools
N3754904549	Normally Open Solenoid Valve for 3/8" and 1/2" NPT pneumatic tools

AcraDyne™ IEC Controller

In addition to the AIMCO Socket Tray, the 013-13-IEC Cable/Power Supply is required

To connect to the IEC, simply plug the yellow connector into the left side of the AIMCO Socket Tray and the Power Supply into AC Power. Plug in the 25-pin connector into the I/O connector on the IEC controller and the AIMCO Socket Tray is ready to use.

AcraDyne™ Evolution Controller

In addition to the AIMCO Socket Tray, the 013-13-EV Cable/Power Supply is required

To connect to the Evolution controller, simply plug the yellow connector into the left side of the AIMCO Socket Tray and the Power Supply into AC Power. Plug in the two, 12-pin Phoenix connectors into the I/O connectors on the Evolution controller (12 position, top right, Inputs. Connector with jumper wires should be placed on the front connection) and the AIMCO Socket Tray connection is complete. It will be necessary to setup logic using Toolware™ in the Evolution controller. Please refer to the Evolution Controller and Toolware manuals for further guidance.

When writing the logic within Toolware™, Input 3 = Disable, Input 4 = BCD 1, Input 5 = BCD 2, Input 6 = BCD 3 .

AIMCO Technical Services can assist with the installation by e-mailing an appropriate logic program upon request.

Uryu UEC-4500 Controller

In addition to the AIMCO Socket Tray, the 013-13-45 Cable/Power Supply is required.

To connect to the UEC-4500:

1. Plug the yellow connector into the left side of the AIMCO Socket Tray.
2. Connect the COM wire from the AIMCO Socket Tray to the COM terminal (top row, inputs) on the UEC-4500.
3. Connect the Reset wire from the AIMCO Socket Tray to the Reset terminal (top row, inputs) on the UEC-4500.
4. Connect the Work A wire from the AIMCO Socket Tray to the LS1 terminal on the UEC-4500.
5. Connect the Work B wire from the AIMCO Socket Tray to the Start terminal on the UEC-4500.

For UEP tools:

- Connect the LS1 wire to one of the Cut terminals on the UEP driver box
- Using a jumper wire (supplied), connect the COM terminal (top row, inputs) to the other Cut terminal on the UEP driver box

Pneumatic Tools

For UL Series Tools:

Connect the Inhibit wire from the AIMCO Socket Tray to the 0 volt connection on the UL Tool Solenoid Valve.

For Non-UL Series Tools:

- Install the correct, normally open solenoid valve (MME-44ZES-D024 for 1/4" NPT tools or N3754904549 for 3/8" NPT tools or larger) in the air supply line to the tool close to the supply fitting.
- Connect the LS1 wire to one terminal on the solenoid valve.
- Using a jumper wire (not supplied) connect the COM terminal (top row, inputs) to the other terminal on the solenoid valve.

Changes to the factory defaulted Modes within the UEC-4500 will need to be made prior to use of the AIMCO Socket Tray. Please consult the UEC-4500 manual for details.

Connecting Your AIMCO Socket Tray

Uryu UEC-4800 Controller

In addition to the AIMCO Socket Tray, the 013-13-48 Cable/Power Supply is required.

To connect to the UEC-4800:

1. Plug the yellow connector into the left side of the AIMCO Socket Tray.
2. Connect the COM wire from the AIMCO Socket Tray to the COM terminal (top row, inputs) on the UEC-4800.
3. Connect the Work A wire from the AIMCO Socket Tray to the Work A terminal on the UEC-4800.
4. Connect the Work B wire from the AIMCO Socket Tray to the Work B terminal on the UEC-4800.
5. Connect the Start wire from the AIMCO Socket Tray to the Start terminal on the UEC-4800.

For UEP Tools:

- Connect the LS1 wire to one of the Cut terminals on the UEP driver box.
- Using a jumper wire (supplied with socket tray).

- Connect the COM terminal (top row, inputs) to the other Cut terminal on the UEP driver box.

For Pneumatic Tools:

- Install the correct, normally open solenoid valve (MME-44ZES-D024 for 1/4" NPT tools or N3754904549 for 3/8" NPT tools or larger) in the air supply line to the tool close to the supply fitting.
- Connect the LS1 wire to one terminal on the solenoid valve
- Using a jumper wire (supplied with socket tray) connect the COM terminal (top row, inputs) to the other terminal on the solenoid valve

Changes to the factory defaulted Modes within the UEC-4800 will need to be made prior to use of the AIMCO Socket Tray. Please consult the UEC-4800 manual for details.

I-Socket Tray Position vs. BCD Output

Removed	BCD Output Status			
	BCD #1	BCD #2	BCD #3	BCD #4
1	off	off	off	off
2	ON	off	off	off
3	off	ON	off	off
4	ON	ON	off	off
5	off	off	ON	off
6	ON	off	ON	off
7	off	ON	ON	off
8	ON	ON	ON	off
>2	off	off	off	ON
All in	off	off	off	ON

Switch Settings

Dip Switch Settings

Prior to shipment, it is advisable to consult with AIMCO regarding the proper setup of the dip switches inside the socket tray. However, this is not always possible, due to specification changes, use of multiple brands/series of controllers, etc.

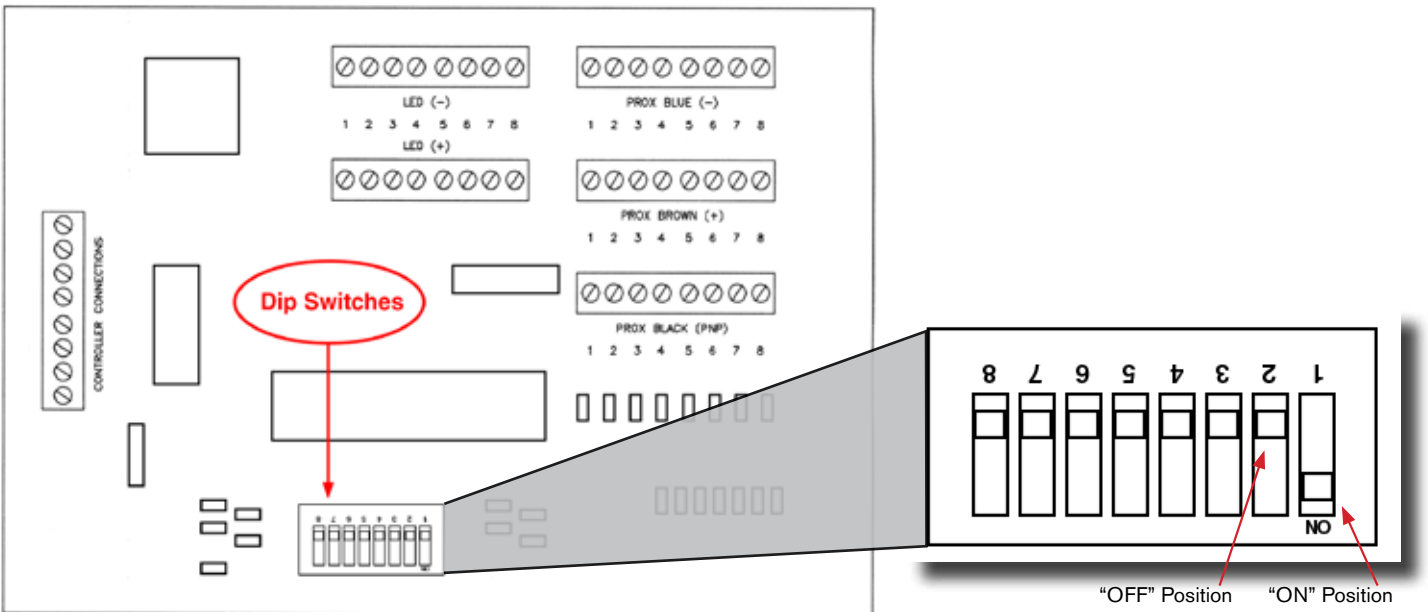

Switch Functions

Switch	Function	OFF Position	ON Position
1	No. of sockets	See below	See below
2	No. of sockets	See below	See below
3	No. of sockets	See below	See below
4	Binary Number Type	Binary	Binary + 1
5	LED Mode	LEDs on with socket out	LEDs off with socket out
6	Disable Method	All PS bits on	Output for enable/disable
7	Enable Mode*	Enable high	Enable low
8	Spare		

*Switch must be set to "on" for switch 7 function properly.

Setting the Number of Sockets in the Tray

# SKTS	Switch 1	Switch 2	Switch 3
2	0	0	0
3	1	0	0
4	0	1	0
5	1	1	0
6	0	0	1
7	1	0	1
8	0	1	1

Explanation of Switch Functions

Binary Number Type: Binary number produced is either pure binary or binary +1.

Example: 111 is pure binary 7. In binary +1, 111 actually produces 8.

LED Mode:

OFF When socket is removed, the associated LED light comes on.

ON When socket is removed, the LED light goes out.

Disable Method:

OFF When a socket error condition exists, all parameter set bits are turned on.

ON When a socket error condition exists, a single output is energized to disable the tool through the controller.

Enable Mode: Switch 6 must be set to "ON" for this function to apply.

OFF Signal goes high to enable a tool which is normally disabled.

ON Signal goes low to remove the disable signal from the tool.

Wiring for AcraDyne Controller

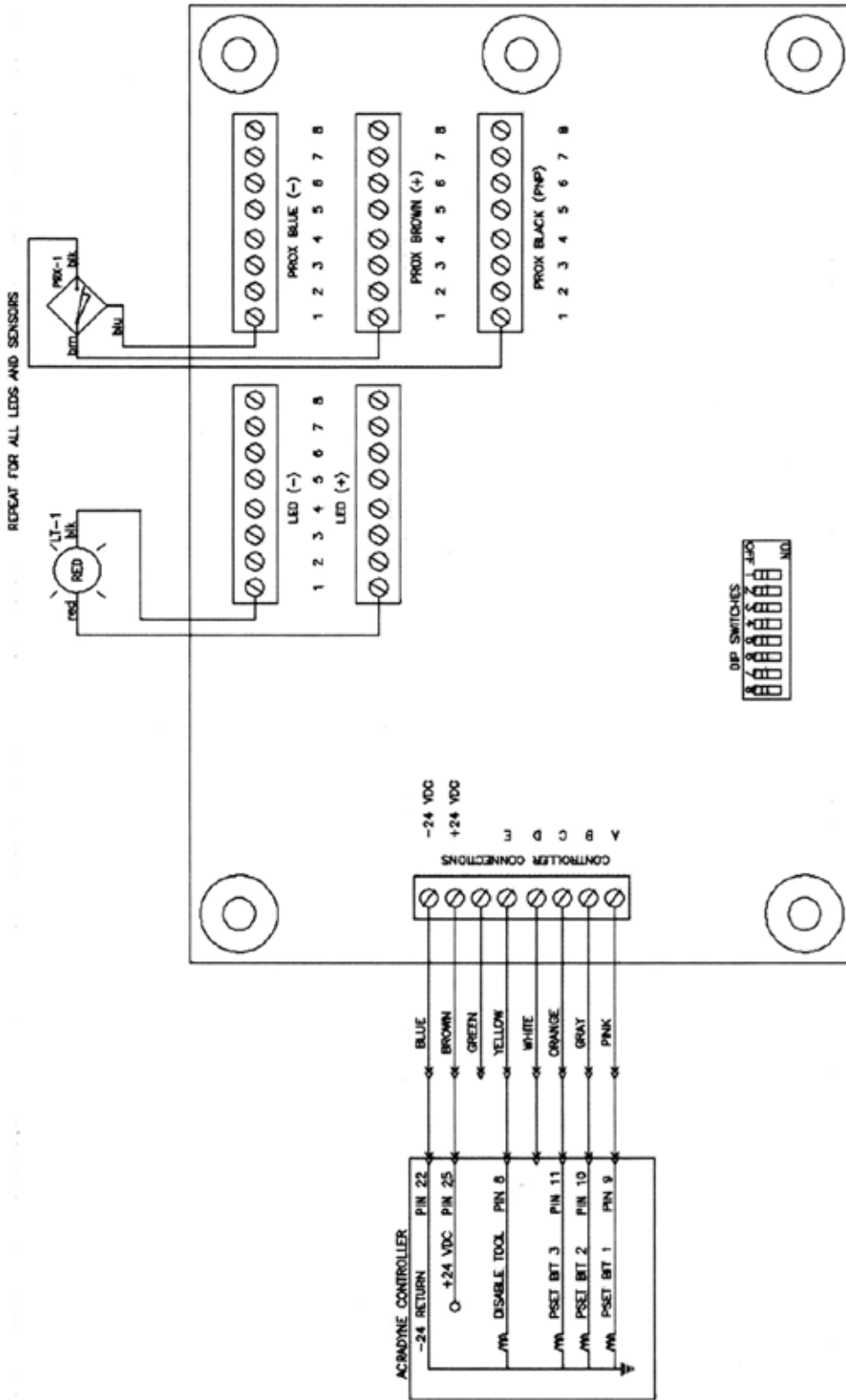

Wiring for UEC Controller

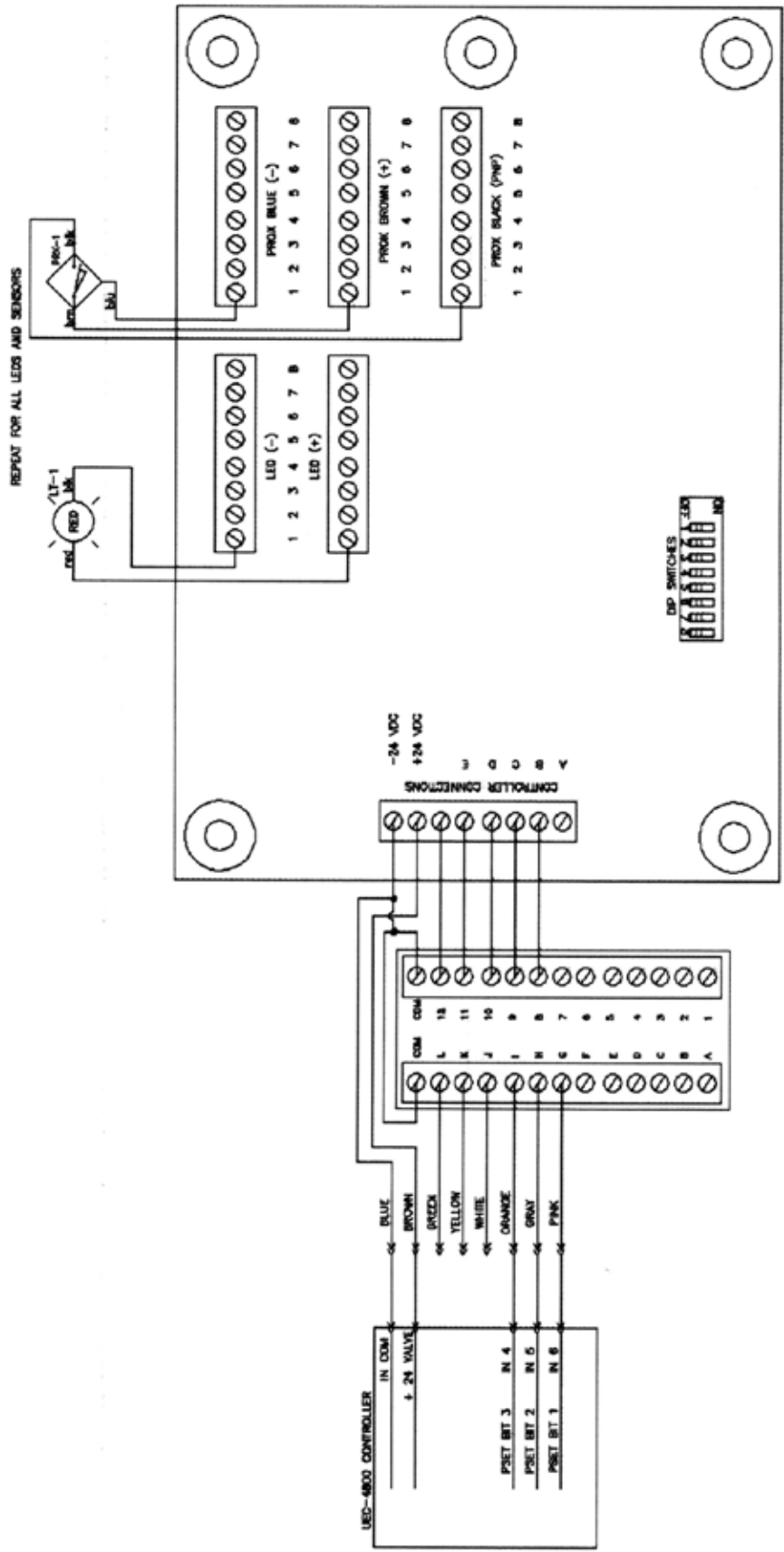

Board Input/Output

Inputs

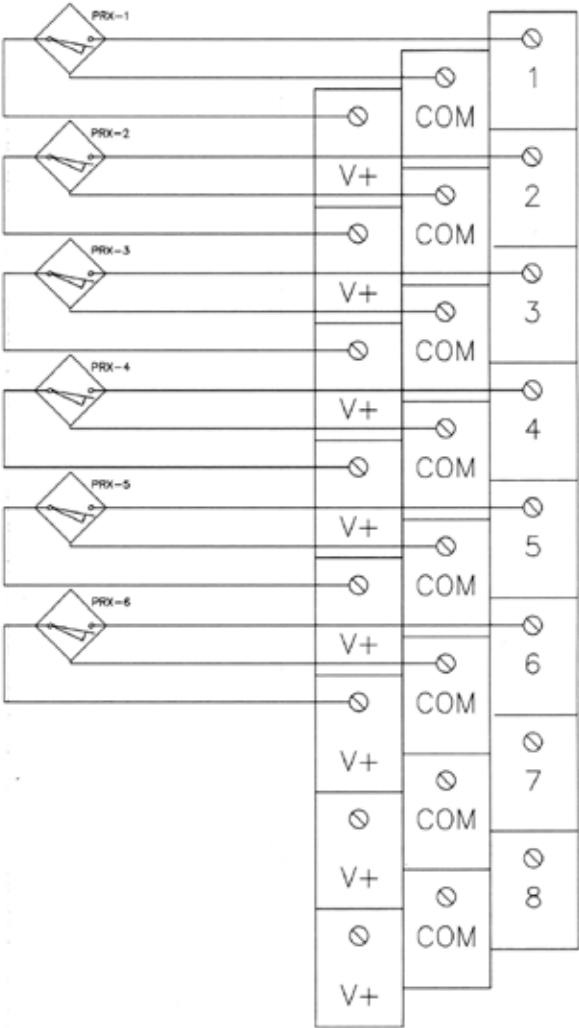

Outputs

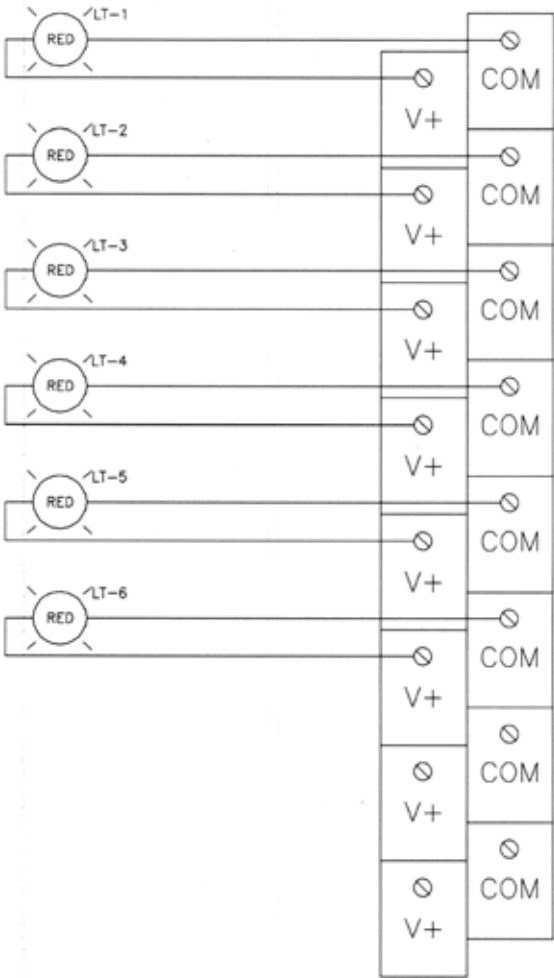



CORPORATE HEADQUARTERS

10000 S.E. Pine St.
Portland, OR 97216

(800) 852-1368
FAX (800) 582-9015

Ave. Cristóbal Colon 14529
Chihuahua, Chihuahua. 31109
Mexico
52-614-380-1010
FAX 52-614-380-1019