



AcraDyne 1000 & 2000 Series Pistol Nutrunners Operations Manual



PO Box 16460, Portland OR 97292-0460 • 800-852-1368 • Fax 800-582-9015

www.aimco-global.com

Introduction

Thank you for purchasing this AcraDyne DC electric assembly tool, one of the lightest and fastest DC electric assembly tools on the market. When used with the AcraDyne iEC tool controller, this tool will provide excellent productivity, ergonomics, reliability and quality on a wide range of industrial assembly applications.

Safety Information

SAVE THESE INSTRUCTIONS

1) WORK AREA

- a) Keep work area clean and well lit. Cluttered and dark areas invite accidents.
- b) Do not operate power tools in explosive atmospheres, such as the presence of flammable liquids, gases or dust. Power tools create sparks which may ignite the dust or fumes.
- c) Keep children and bystanders away while operating a power tool. Distractions can cause you to lose control.

2) ELECTRICAL SAFETY

- a) Power tool plugs must match the outlet. Never modify the plug in any way. Do not use any adapter plugs with earthed (grounded) power tools. Unmodified plugs and matching outlets will reduce risk of electric shock.
- b) Avoid body contact with earthed or grounded surfaces such as pipes, radiators, ranges and refrigerators. There is an increased risk of electric shock if your body is earthed or grounded.
- c) Do not expose power tools to rain or wet conditions. Water entering a power tool will increase the risk of electric shock.
- d) Do not abuse the cord. Never use the cord for carrying, pulling or unplugging the power tool. Keep cord away from heat, oil, sharp edges or moving parts. Damaged or entangled cords increase the risk of electric shock.
- e) When operating a power tool outdoors, use an extension cord suitable for outdoor use. Use of a cord suitable of outdoor use reduces the risk of electric shock
- f) It is not recommended to use AcraDyne controllers or tools outside or to use an extension cord to connect the controller to a power source.

3) PERSONAL SAFETY

- a) Stay alert, watch what you are doing and use common sense when operating a power tool. Do not use a power tool while you are tired or under the influence of drugs, alcohol or medication. A moment of inattention while operating power tools may result in serious personal injury.
- b) Use safety equipment. Always wear eye protection. Safety equipment such as dust mask, non-skid safety shoes, hard hat, or hearing protection used for appropriate conditions will reduce personal injuries. If the maximum duty cycle of the attached tool is exceeded or the tool temperature exceeds 50° C., then the operator should wear protective hand wear (gloves).
- c) Avoid accidental starting. Ensure the switch is in the off-position before plugging in. Carrying power tools with your finger on the switch or plugging in power tools that have the switch on invites accidents.
- d) Remove any adjusting key or wrench before turning the power tool on. A wrench or a key left attached to a rotating part of the power tool may result in personal injury.
- e) Do not overreach. Keep proper footing and balance at all times. This enables better control of the power tool in unexpected situations.
- f) Dress properly. Do not wear loose clothing or jewelry. Keep your hair, clothing and gloves away from moving parts. Loose clothes, jewelry or long hair can be caught in moving parts.
- g) If devices are provided for the connection of dust extraction and collection facilities, ensure these are connected and properly used. Use of these devices can reduce dust-related hazards.

4) POWER TOOL USE AND CARE

- a) Do not force the power tool. Use the correct power tool for your application. The correct power tool will do the job better and safer at the rate for which it was designed.
- b) Do not use the power tool if the switch does not turn it on and off. Any power tool that cannot be controlled with the switch is dangerous and must be repaired.
- c) This product is designed to be used in combination with the AcraDyne iEC DC tool controller for intermittent hand-held or fixtured assembly processes.

OPERATIONS



1. Connect the tool cable to the iEC controller and the tool:

The tool cable has curved alignment tabs and slots built into the connectors at each end to ensure proper alignment and connection with the tool and controller.

Make sure that power is not turned on at the controller before making any connections. Align the female connector on the cable with the male connector on the tool and insert the cable onto the tool, then slide the connector nut onto the threads on the cable and turn clockwise until hand-tight.

Align the male connector tab on the other end of the tool cable with the female slot on the controller and insert the cable into the connector, then slide the metal outer cover onto the connection threads on the controller and turn clockwise until hand-tight.

2. Multifunction Button Operation:

The tool will flash all LED lights three times when power is first turned on at the controller. After the controller finishes initializing and displays a target torque value, the multifunction button (MFB) is used to toggle the tool from clockwise mode (FWD) to counter-clockwise operation mode (REV). The MFB is the small button opposite the trigger.

The tool will initially start in clockwise mode and will have no LED lights turned on. If the trigger is pressed, the tool will turn on the blue LED meaning the tightening operation is underway. Pressing the MFB will cause the tool to flash yellow and red LED lights. Pressing the MFB again will switch the tool back FWD mode and will indicate this with no LED lights turned on.

3. Start Trigger Operation:

To start the tool, depress the start trigger. Blue LED lights will be displayed while tightening a bolt. The tool will stop automatically when it senses its target torque value or if no torque is sensed in a specified time period. After a cycle is complete, the tool will display green LED lights for a success, or red LED lights for failure to reach torque/angle.

A complete tool system consists of the following items:



1000 SERIES PISTOL NUTRUNNERS

Assembly for: AEP4A12003A, AEP4A12006A, AEP4A12011A, AEP4A12014A, AEP4A12018A, AEP4A12022A

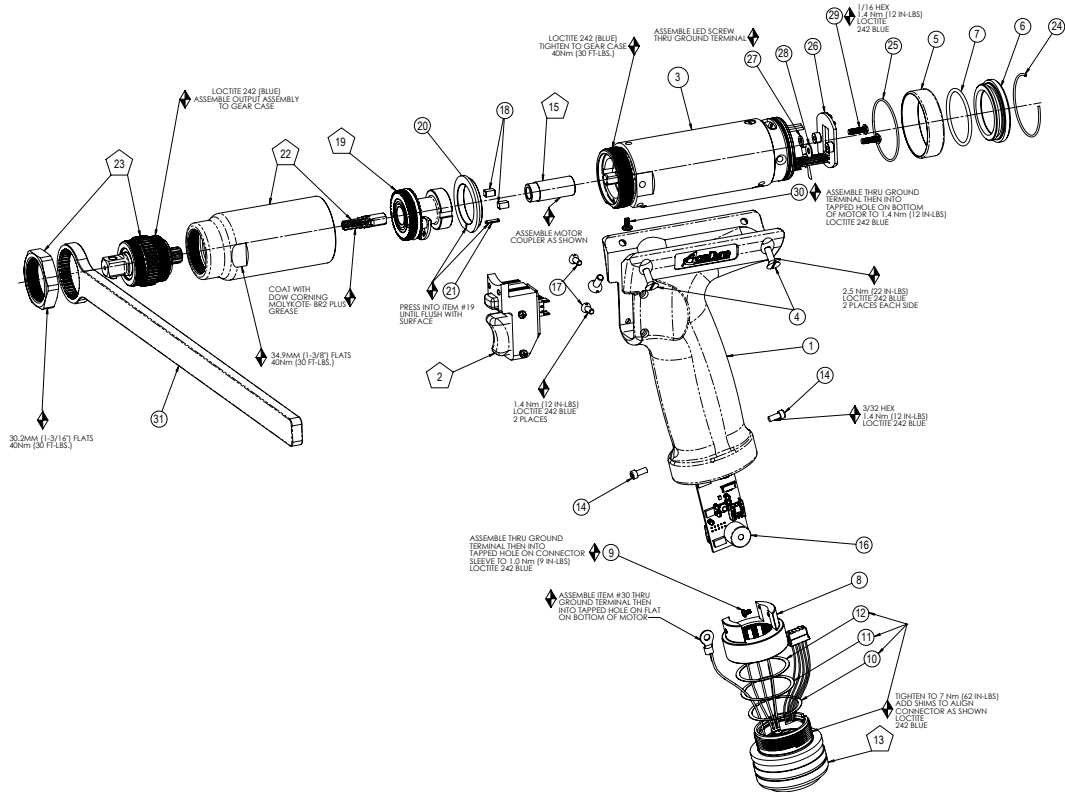

ITEM#	AEP4A 12003A	AEP4A 12006A	AEP4A 12011A	AEP4A 12014A	AEP4A 12018A	AEP4A 12022A	QTY.	PART #	DESCRIPTION
1	X	X	X	X	X	X	1	24867	PISTOL HANDLE, 1000 SERIES
2	X	X	X	X	X	X	1	24874	SWITCH SUB-ASSEMBLY
3	X	X	X	X	X	X	1	24863	PISTOL MOTOR ASM., 1000 SERIES
4	X	X	X	X	X	X	4	24933	FLAT HEAD CAP SCREW
5	X	X	X	X	X	X	1	24873	LIGHT RING
6	X	X	X	X	X	X	1	24871	END CAP, PISTOL MOTOR
7	X	X	X	X	X	X	1	24895	O-RING, END CAP, PISTOL MOTOR
8	X	X	X	X	X	X	1	24870	CONNECTOR SLEEVE, PISTOL HANDLE
9	X	X	X	X	X	X	1	25420	SCREW, PHM 2-56 X .125, STAINLESS STEEL, PLAIN
10	X	X	X	X	X	X	1	25271	SHIM. - .002
11	X	X	X	X	X	X	1	25272	SHIM. - .005
12	X	X	X	X	X	X	1	25273	SHIM. - .010
13	X	X	X	X	X	X	1	24677	TOOL CONNECTOR ASSEMBLY
14	X	X	X	X	X	X	2	24935	SOC HD CAP SCREWS
15	X	X	X	X	X	X	1	24780	MOTOR COUPLER SUB-ASM.
16	X	X	X	X	X	X	1	24888	T.I.D. BOARD ASM., GEN IV
17	X	X	X	X	X	X	2	24934	FLAT HEAD CAP SCREW
18	X	X	X	X	X	X	2	24729	KEY
19	X						1	24777	TRANSDUCER SUB-ASM., 3Nm
		X					1	24778	TRANSDUCER SUB-ASM., 8Nm
			X	X	X	X	1	24779	TRANSDUCER SUB-ASM., 20Nm
20	X	X	X	X	X	X	1	24719	TRANSDUCER ADAPTOR
21	X	X	X	X	X	X	1	24688	ROLL PIN, 1/16 x 5/16" LONG
22	X	X					1	24860	GEAR CASE SUB-ASM 6T
			X				1	24709	GEAR CASE SUB-ASM, 14T/14T
				X			1	24792	GEAR CASE SUB-ASM., 12T/12T
					X		1	24710	GEAR CASE SUB-ASM, 8T/14T
						X	1	24781	GEAR CASE ASM, 6T/14T
23	X	X					1	24896	STRAIGHT OUTPUT ASM, 1/4" HEX Q.C.
			X	X	X	X	1	24699	STRAIGHT OUTPUT ASM., 3/8" SQ. DR.
24	X	X	X	X	X	X	1	24686	RETAINING RING, LEVER LIGHT RING
25	X	X	X	X	X	X	1	24687	O-RING, LIGHT RING, LEVER
26	X	X	X	X	X	X	1	24886	CIRCUIT BOARD ASM - PISTOL/ FIXTURED TOOLS
27	X	X	X	X	X	X	1	25424	GROUND WIRE ASM.
28	X	X	X	X	X	X	1	25421	WASHER, #4 SCREW
29	X	X	X	X	X	X	2	24930	SCREW, AMP BOARD
30	X	X	X	X	X	X	1	25419	SCREW, PHM 4-40 X .188 , STEEL, PLAIN
31			X	X	X	X	1	24696	REACTION BAR, ALUMINUM, 1000 SERIES

2000 SERIES PISTOL NUTRUNNERS

Assembly for: AEP4A22020A, AEP4A22025A, AEP4A22030A,

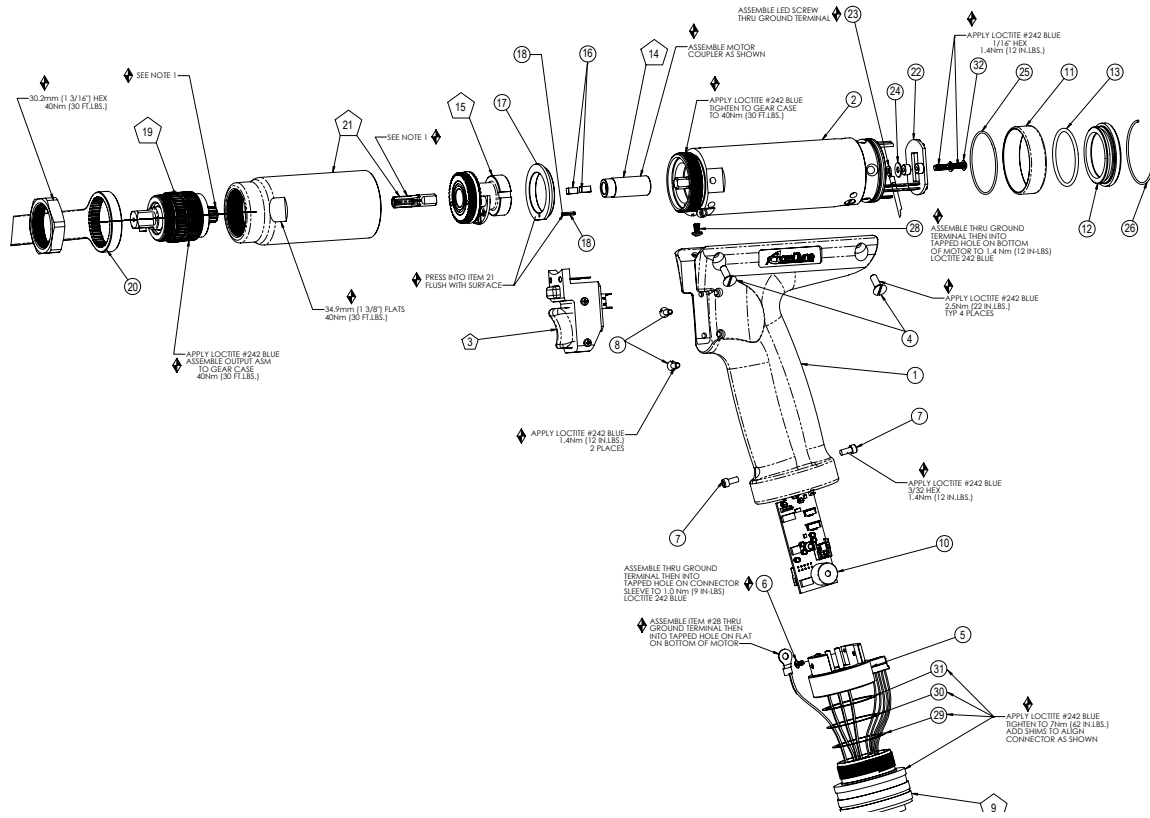

ITEM#	AEP4A 22020A	AEP4A 22025A	AEP4A 22030A	QTY.	PART #	DESCRIPTION
1	X	X	X	1	24868	PISTOL HANDLE, 2000 SERIES
2	X	X	X	1	24866	PISTOL MOTOR ASSEMBLY
3	X	X	X	1	24874	SWITCH SUB-ASSEMBLY
4	X	X	X	4	24933	FLAT HEAD CAP SCREW
5	X	X	X	1	24870	CONNECTOR SLEEVE, PISTOL HANDLE
6	X	X	X	1	25420	SCREW, PHM 2-56 X .125, STAINLESS STEEL, PLAIN
7	X	X	X	2	24935	SOC HD CAP SCREWS
8	X	X	X	2	24934	FLAT HEAD CAP SCREW
9	X	X	X	1	24677	TOOL CONNECTOR ASSEMBLY
10	X	X	X	1	24888	T.I.D. BOARD ASM., GEN IV
11	X	X	X	1	24873	LIGHT RING
12	X	X	X	1	24871	END CAP, PISTOL MOTOR
13	X	X	X	1	24895	O-RING, END CAP, PISTOL MOTOR
14	X	X	X	1	24780	MOTOR COUPLER SUB-ASM.
15	X			1	24779	TRANSDUCER SUB-ASM., 20Nm
		X	X	1	24908	TRANSDUCER SUB-ASM., 40Nm
16	X	X	X	2	24729	KEY
17	X	X	X	1	24719	TRANSDUCER ADAPTOR
18	X	X	X	1	24688	ROLL PIN, 1/16 x 5/16" LONG
19	X	X	X	1	24698	STRAIGHT OUTPUT ASM., 3/8" SQ. DR., 2000 SERIES
20	X	X	X	1	24697	REACTION BAR, STEEL, 2000 SERIES
21	X			1	24901	GEAR CASE SUB-ASM., 14T/14T
		X		1	24894	GEAR CASE SUB-ASM., 12T/12T
			X	1	24902	GEAR CASE SUB-ASM., 8T/14T
22	X	X	X	1	24886	CIRCUIT BOARD ASM - PISTOL/ FIXTURED TOOLS
23	X	X	X	1	25424	GROUND WIRE ASM.
24	X	X	X	1	25421	WASHER, #4 SCREW
25	X	X	X	1	24687	O-RING, LIGHT RING, LEVER
26	X	X	X	1	24686	RETAINING RING, LEVER LIGHT RING
27	X	X	X	1	25193	RING TERMINAL, #6, 22-18 AWG
28	X	X	X	1	25419	SCREW, PHM 4-40 X .188 , STEEL, PLAIN
29	X	X	X	1	25271	SHIM. -.002
30	X	X	X	1	25272	SHIM. -.005
31	X	X	X	1	25273	SHIM. -.010
32	X	X	X	2	24930	SCREW, AMP BOARD

Specifications

Environmental

- Operating Temperature: 0°C to 32°C
- Storage Temperature: 0°C to 65°C
- Humidity:
 - 5% to 90% RH, Non-Condensing, for temperatures 0°C to 40°C
 - 5% to 60% RH, Non-Condensing, for temperatures 0°C to 65°C
- Maximum Altitude of Operation: 3000m
- Maximum decibel level: 73 dB(A)

Electrical

- Motor Type: BLDC
 - Motor Phase Voltage: 160 Volts Pulse DC @ Controller Supply Voltage of 120 RMS, or 320 Volts Pulse DC @ Controller Supply Voltage of 230 RMS
- Duty Cycle: The Nutrunner tools are intended for intermittent operation with recommended maximum duty cycles not to exceed 33%. Note: actual maximum duty cycles are dependant upon several factors including: Ambient Temperature, Tool selection, Joint conditions, Fastening-parameter programming, and different applications and strategies. For optimum duty cycle determination, please contact your AcraDyne sales representative.

Physical

- 1000 Series Tool: 1.5 lbs/.68 kg - 2.6 lbs/1.18 kg
- 2000 Series Tool : 2.5 lbs/1.16 kg - 3.60 lbs/1.63 kg

Performance

1000 Series Tools

Torque Range: 3 - 22 NM

Speed Range: 560 - 2625 RPM

2000 Series Tools

Torque range: 10 - 68 NM

Speed Range: 320 - 2080RPM



CORPORATE HEADQUARTERS
10000 S.E. Pine St.
Portland, OR 97216

(800) 852-1368
FAX (800) 582-9015

Ave. Cristóbal Colon 14529
Chihuahua, Chihuahua. 31109
Mexico
52-614-380-1010
FAX 52-614-380-1019