



# **AcraDyne Gen III 2000 Series Tubenut runners Operations Manual**



---

PO Box 16460, Portland OR 97292-0460 • 800-852-1368 • Fax 800-582-9015

[www.aimco-global.com](http://www.aimco-global.com)

# Introduction

Thank you for purchasing this AcraDyne DC electric assembly tool, one of the lightest and fastest DC electric assembly tools on the market. When used with the AcraDyne iEC tool controller, this tool will provide excellent productivity, ergonomics, reliability and quality on a wide range of industrial assembly applications.

## Safety Information

### SAVE THESE INSTRUCTIONS

#### 1) WORK AREA

- a) Keep work area clean and well lit. Cluttered and dark areas invite accidents.
- b) Do not operate power tools in explosive atmospheres, such as the presence of flammable liquids, gases or dust. Power tools create sparks which may ignite the dust or fumes.
- c) Keep children and bystanders away while operating a power tool. Distractions can cause you to lose control.

#### 2) ELECTRICAL SAFETY

- a) Power tool plugs must match the outlet. Never modify the plug in any way. Do not use any adapter plugs with earthed (grounded) power tools. Unmodified plugs and matching outlets will reduce risk of electric shock.
- b) Avoid body contact with earthed or grounded surfaces such as pipes, radiators, ranges and refrigerators. There is an increased risk of electric shock if your body is earthed or grounded.
- c) Do not expose power tools to rain or wet conditions. Water entering a power tool will increase the risk of electric shock.
- d) Do not abuse the cord. Never use the cord for carrying, pulling or unplugging the power tool. Keep cord away from heat, oil, sharp edges or moving parts. Damaged or entangled cords increase the risk of electric shock.
- e) When operating a power tool outdoors, use an extension cord suitable for outdoor use. Use of a cord suitable of outdoor use reduces the risk of electric shock
- f) It is not recommended to use AcraDyne controllers or tools outside or to use an extension cord to connect the controller to a power source.

#### 3) PERSONAL SAFETY

- a) Stay alert, watch what you are doing and use common sense when operating a power tool. Do not use a power tool while you are tired or under the influence of drugs, alcohol or medication. A moment of inattention while operating power tools may result in serious personal injury.
- b) Use safety equipment. Always wear eye protection. Safety equipment such as dust mask, non-skid safety shoes, hard hat, or hearing protection used for appropriate conditions will reduce personal injuries. If the maximum duty cycle of the attached tool is exceeded or the tool temperature exceeds 50° C., then the operator should wear protective hand wear (gloves).
- c) Avoid accidental starting. Ensure the switch is in the off-position before plugging in. Carrying power tools with your finger on the switch or plugging in power tools that have the switch on invites accidents.
- d) Remove any adjusting key or wrench before turning the power tool on. A wrench or a key left attached to a rotating part of the power tool may result in personal injury.
- e) Do not overreach. Keep proper footing and balance at all times. This enables better control of the power tool in unexpected situations.
- f) Dress properly. Do not wear loose clothing or jewelry. Keep your hair, clothing and gloves away from moving parts. Loose clothes, jewelry or long hair can be caught in moving parts.
- g) If devices are provided for the connection of dust extraction and collection facilities, ensure these are connected and properly used. Use of these devices can reduce dust-related hazards.

#### 4) POWER TOOL USE AND CARE

- a) Do not force the power tool. Use the correct power tool for your application. The correct power tool will do the job better and safer at the rate for which it was designed.
- b) Do not use the power tool if the switch does not turn it on and off. Any power tool that cannot be controlled with the switch is dangerous and must be repaired.
- c) This product is designed to be used in combination with the AcraDyne iEC DC tool controller for intermittent hand-held or fixtured assembly processes.

# OPERATIONS

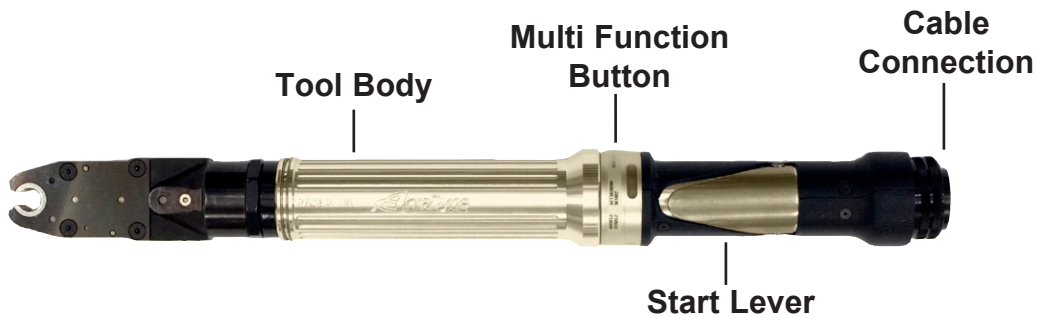

## 1. Connect the tool cable to the iEC controller and the tool:

The tool cable has curved alignment tabs and slots built into the connectors at each end to ensure proper alignment and connection with the tool and controller.

**Make sure that power is not turned on at the controller before making any connections.** Align the female connector on the cable with the male connector on the tool and insert the cable onto the tool, then slide the connector nut onto the threads on the cable and turn clockwise until hand-tight.

Align the male connector tab on the other end of the tool cable with the female slot on the controller and insert the cable into the connector, then slide the metal outer cover onto the connection threads on the controller and turn clockwise until hand-tight.

## 2. Multifunction Button Operation:

The tool will flash all LED lights three times when power is first turned on at the controller. After the controller finishes initializing and displays a target torque value, the multifunction button (MFB) is used to toggle the tool from clockwise mode (FWD) to counter-clockwise operation mode (REV). The MFB is the small button opposite the trigger.

The tool will initially start in clockwise mode and will have no LED lights turned on. If the trigger is pressed, the tool will turn on the blue LED meaning the tightening operation is underway. Pressing the MFB will cause the tool to flash yellow and red LED lights. Pressing the MFB again will switch the tool back FWD mode and will indicate this with no LED lights turned on.

## 3. Start Lever Operation:

To start the tool, depress the start lever. Blue LED lights will be displayed while tightening a bolt. The tool will stop automatically when it senses its target torque value or if no torque is sensed in a specified time period. After a cycle is complete, the tool will display green LED lights for a success, or red LED lights for failure to reach torque/angle.

## A complete tool system consists of the following items:

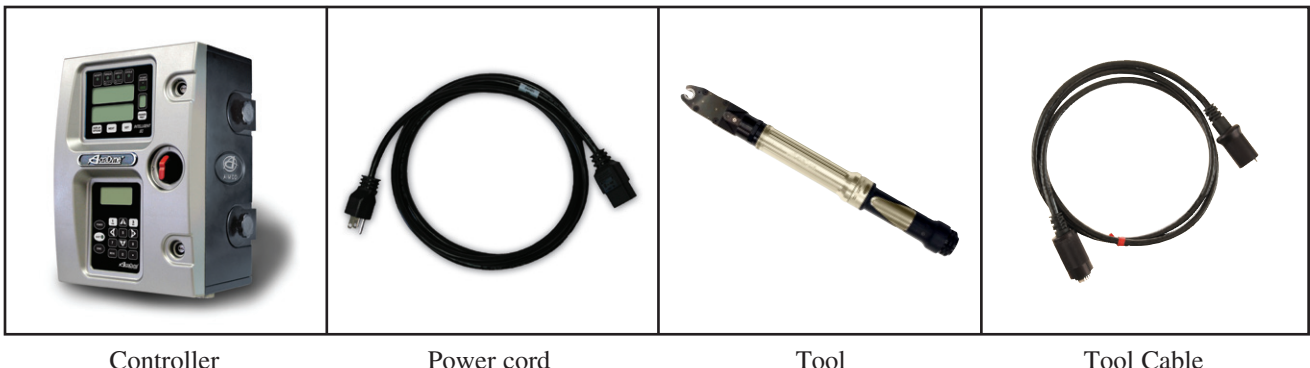

# GEN III 2000 SERIES TUBENUT RUNNERS

Assembly for: AET32020A, AET32025A, AET32035A and AET32050A

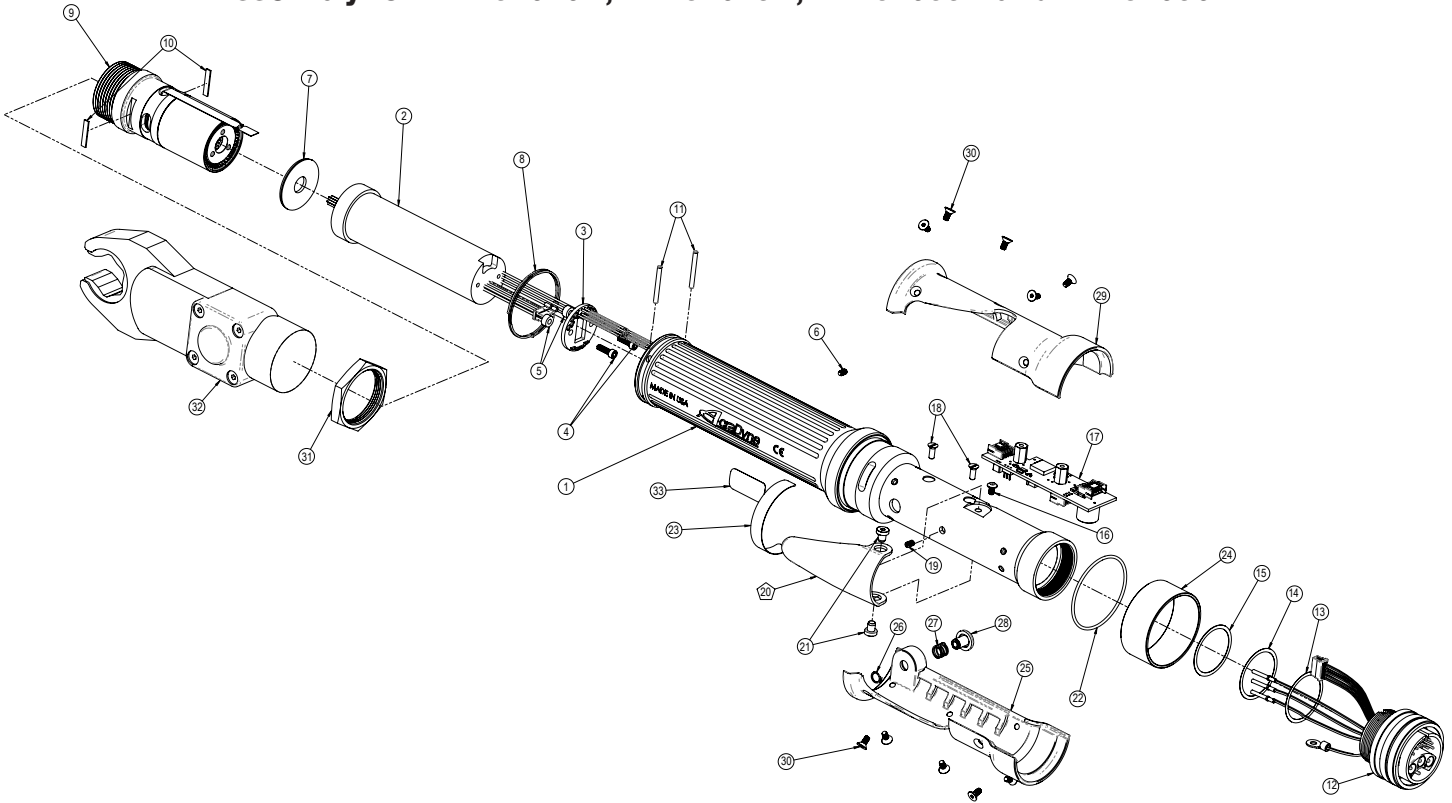

ITEM #	AET 32020A	AET 32025A	AET 32035A	AET 32050A	QTY.	PART #	DESCRIPTION
1	X	X	X	X	1	25064	MOTOR HOUSING
2	X	X	X	X	1	25425	MOTOR ASM., 5:1, 2000 SERIES GEN III
3	X	X	X	X	1	25063	LED BOARD ASM.
4	X	X	X	X	2	25075	SCREW, SHC 4-40X.375, STEEL, BLACK OXIDE
5	X	X	X	X	2	25429	STAND-OFF, LED, 2000 SERIES
6	X	X	X	X	1	25073	SCREW, SET 4-40X.375, STEEL, BLACK OXIDE
7	X	X	X	X	1	24254	SPACER, PILOT
8	X	X	X	X	1	25298	SPIRAL RETAINING RING
9	X	X	X	X	1	21122	TUBENUT ADAPTOR ASSEMBLY
10	X	X	X	X	2	24272	ADAPTOR INSERT
11	X	X	X	X	2	24324	DOWEL PIN 3/32 Dia x 7/8 LONG
12	X	X	X	X	1	25418	TOOL CONNECTOR ASM GEN III TOOLS
13	X	X	X	X	1	25271	SHIM. - .002
14	X	X	X	X	1	25272	SHIM. - .005
15	X	X	X	X	1	25273	SHIM. - .010
16	X	X	X	X	1	25102	Screw, BHC4-40X.188, STEEL, BLACK OXIDE
17	X	X	X	X	1	25402	T.I.D. BOARD ASM. - GEN III
18	X	X	X	X	2	24934	FLAT HEAD CAP SCREW
19	X	X	X	X	1	25071	SPRING, LEVER
20	X	X	X	X	1	25074	LEVER ASSEMBLY
21	X	X	X	X	2	20061	SCREW, LEVER
22	X	X	X	X	1	25072	O-RING, LED LIGHT RING COVER
23	X	X	X	X	1	20534	3000 SERIAL/MODEL LABEL
24	X	X	X	X	1	25058	LIGHT RING COVER, LED
25	X	X	X	X	1	25060	HANDLE COVER, REV. BUTTON
26	X	X	X	X	1	24679	RETAINING RNG
27	X	X	X	X	1	24683	SPRING, REV BUTTON
28	X	X	X	X	1	24706	REV BUTTON SUB-ASSEMBLY
29	X	X	X	X	1	25059	HANDLE COVER
30	X	X	X	X	10	24940	SCREW, FHSC 4-40 X .25 LG., STEEL, BLACK OXIDE
31	X	X	X	X	1	21748	LOCK NUT
32	X				1	21631	TUBENUT HEAD ASM.
		X			1	21632	
			X		1	21633	
				X	1	21634	
33	X	X	X	X	1	22141	SAFETY LABEL

# Specifications

## Environmental

- Operating Temperature: 0°C to 32°C
- Storage Temperature: 0°C to 65°C
- Humidity:
  - 5% to 90% RH, Non-Condensing, for temperatures 0°C to 40°C
  - 5% to 60% RH, Non-Condensing, for temperatures 0°C to 65°C
- Maximum Altitude of Operation: 3000m
- Maximum decibel level: 73 dB(A)

## Electrical

- Motor Type: BLDC
  - Motor Phase Voltage: 160 Volts Pulse DC @ Controller Supply Voltage of 120 RMS, or 320 Volts Pulse DC @ Controller Supply Voltage of 230 RMS
- Duty Cycle: The Nutrunner tools are intended for intermittent operation with recommended maximum duty cycles not to exceed 33%. Note: actual maximum duty cycles are dependant upon several factors including: Ambient Temperature, Tool selection, Joint conditions, Fastening-parameter programming, and different applications and strategies. For optimum duty cycle determination, please contact your AcraDyne sales representative.

## Physical

- 2.9 lbs/1.3 kg - 5.4 lbs/2.5 kg

## Performance

- Torque range: 4 - 40 NM
- Speed Range: 240 - 580 RPM







**CORPORATE HEADQUARTERS**  
10000 S.E. Pine St.  
Portland, OR 97216

(800) 852-1368  
FAX (800) 582-9015

Ave. Cristóbal Colon 14529  
Chihuahua, Chihuahua. 31109  
Mexico  
52-614-380-1010  
FAX 52-614-380-1019