



**UDBP-T Series 40, 50, 60 & 70**  
Lithium Ion Battery-powered  
Direct Drive Auto-shutoff Pulse

**INSTRUCTION MANUAL**





## **DANGER**

Indicates a critical operating step that must be followed. Carefully read this instruction for safe use, understand the contents, and use the tool properly. Keep this manual.



## **CAUTION**

Indicates that incorrect handling may create a hazardous condition, resulting in injury to an operator or physical damage to the tool.

## **For safety operation**

- Basic design of this tool is a lithium ion battery-powered brushless motor rotating an oil pulse unit, which converts the rotation to repeated pulsing for tightening or loosening the fastener. Never use or modify this tool for other purposes for safety and product longevity reasons. Keep hands clear of all rotating assemblies to avoid injury.
- Always follow these instructions to maintain operator safety.
- Operators should be trained using this manual and have access to it.
- When transferring this tool to new personnel, insure that this manual remains with it.



## **DANGER**

1. Wear ear protection if the noise level is higher than 85dB(A) at the worksite.  
Wearing eye protection glasses is recommended.
2. Do not overwork the tool. Doing so can cause motor damage or potentially damage the tool anvil.
3. Hold the tool body firmly during use to maintain control for operator safety.



4. Do not allow unauthorized persons at the worksite. Tool should be used by trained adult personnel and kept away from all children.
5. Use correct charger, power cord, and battery with this tool. Do not charge the battery by other charger. Do not use our charger for other maker's batteries. Doing so could result in battery explosion resulting in property damage or injuries.
6. Read this manual carefully, and charge the battery properly.
  - Use the charger by the specified rated power supply. Do not plug the charger into direct current, generators, or external transformer. This can cause abnormal heat resulting in damage or injury.
  - Do not charge the battery below 0°C or above 40°C.
  - Use charger and recharge batteries in a well ventilated area.
  - Do not cover the charger with any fabric or enclosure.
  - Unplug charger when not in use.
7. Keep foreign objects away from charger, charger contacts and battery contacts to avoid short-circuits at the charger or battery contacts.
8. Maintain a safe work environment/
  - Do not use the tool, charger, battery in any area subject to moisture. No portion of the tool, battery or charger should be exposed to water.
  - Maintain work place by proper lighting.
  - Do not use or charge the tool where any combustible gases are present.
9. Do not expose or dispose of the battery in fire, doing so can cause explosion or generate harmful matter. Do not heat battery by hot plate or others, doing so dissolves insulations, damages protective systems, or can cause explosion and or fire
10. Avoid accidental start of the tool.
  - Do not carry the tool with your fingers touching the trigger.



## DANGER

11. Release your finger from the trigger, and remove the battery from the tool whenever performing the following:
  - Torque adjustment.
  - Replace driver bit or socket.
  - Repairing the tool.
12. Wash your eyes should any battery liquid get to your eyes, and have your eyes examined and medically treated by an eye care doctor immediately.
13. Do not use battery whose running time per charge becomes short.
14. Make sure that your hand is off the trigger when you remove the battery from the tool.
15. Use genuine and original accessories and/or attachments.



## CAUTION

1. Proper fastening time
  - **Battery pulse tool will allow tightening an average of 6 cycles per minute when averaged on a B joint. Softer joints will require less aggressive duty cycles.**
  - Temperature protection will function to stop the tool when motor heats due to exceeding duty cycle.
2. Operation at low temperature extremes
  - The tool operates using a pulse unit containing hydraulic fluid. Should tool be left for extended periods at temperatures below 5°C, the tool may not deliver tightening force initially. This can be remedied by cycling the tool repeatedly on a test fixture which will preheat the pulsing unit to an operating range.
3. Cautions for operation
  - Always maintain good posture during operation.
  - Be sure to keep materials away from rotating parts of the tool at all times.
  - Avoid wearing loose clothing or accessories like necklaces when the tool is in use.
  - Insure that operators are trained on the tool and hold it securely during operation.
  - Unless otherwise necessary, do not run the tool off an application for long periods of time.
  - Do not touch the trigger when you carry the tool to avoid accidental start.
  - Insure that operators are alert and rested when working with the tool to eliminate potential injury from fatigue.
  - Make sure to confirm rotating direction before you operate the tool.
  - Do not give the tool shock by drop or throw handling. Reckless handling will result in accidents or breakage.



## CAUTION

4. Cautions for tool's operation
  - Confirm that no person interferes with work environment or is in a hazardous position.
  - Stop the operation at once, and request service if abnormalities are found with the tool's operation.
5. Do not do recklessly handle the power cord of the charger.
  - Do not pull or hold the power cord to disconnect the power cord or carry the charger.
  - Arrange the power cord so it may not be stepped on, caught, or stressed. Not doing so can cause early breakage.
6. Check for damaged parts.
  - Confirm that the tool functions normally before operation by visually checking the appearance of the battery connection.
  - Do not use charger if it is damaged by a drop or is with damaged power cord. Use of such a charger can cause electric shock or fire.
7. Keep the work place clean always.
  - Untidy place or work stand becomes a cause of accidents.
8. Keep children away from work place.
  - Do not allow others except authorized operators to touch the tool or power cord of the charger.
  - Keep others except authorized operators away from the work place.
9. Store the tool properly when not in use.
  - Keep the tool in a safe place out of the reach of children safe place or in a locked place.
  - Do not keep the tool in the place where the temperature can go up higher than 40°C (unventilated metal storage containers or in cars in summer).
10. Use the tool within it's design limits.
  - For safe and effective use, only use tool on applications that it's capacity can handle.



## CAUTION

11. Overload protect function of motor
  - This function will work to stop the motor when the anvil becomes locked for about 1 second with the trigger depressed.
12. Use appropriate tool whose capacity can cover the requirements of your work.
  - Only connect sockets or bits appropriate to the size of the tool anvil.
13. Perform regular maintenance inspections.
  - Check power cord for damages periodically, request replacements if damage is observed.
  - Maintain handle grips in a clean, dry condition. Avoid and oil or grease.
14. Do not wet battery by water, seawater or other fluids.
15. Charge battery by designated charger always. Charging the battery by non- designated charger will damage battery and can create an unsafe condition.
16. Battery has fixed electrodes of positive and negative. Do not connect battery and the charger when you feel difficulty in connecting the battery to the tool or charger. Incorrect alignment of positive and negative terminals will result in battery damage or injury.
17. Do not make any connections to the battery terminals on the battery or charger by any other means than normal connections as intended in the design of the tool. Any non-standard connections may result in damage or injury.



## CAUTION

18. Do not give battery shock due to drops. Do not throw batteries. Doing so will deform batteries, destroy integrated protection circuit, can result in a charge of the battery by abnormal current or voltage resulting in damage or injury.
19. Do not drive a nail into battery, hit battery by hammer, or impact the battery. Doing so can deform battery, destroy integrated protection circuit, and become a cause of heat, explosion, or fire.
20. Do not attempt to solder anything to batteries. Doing so will dissolve insulations, destroy gas exhaust valve or protection circuit, and becomes a cause of heat, explosion, or fire.
21. Do not place battery in a microwave oven or in a high-pressure container. Battery temperature may rise suddenly and can cause heat, explosion, or fire.
22. Do not cover the battery by flammable items while charging or discharging or place anything atop the charging station. This can cause heat, explode, or burn the battery.
23. Do not disassemble or modify the battery. Batteries have integrated protection mechanism to insure safety. Damaging the mechanism can cause heat, explosion, or fire of the battery.
24. Do stare directly at LED for long periods of time. Doing so will injure your eyes.

# Parts Name

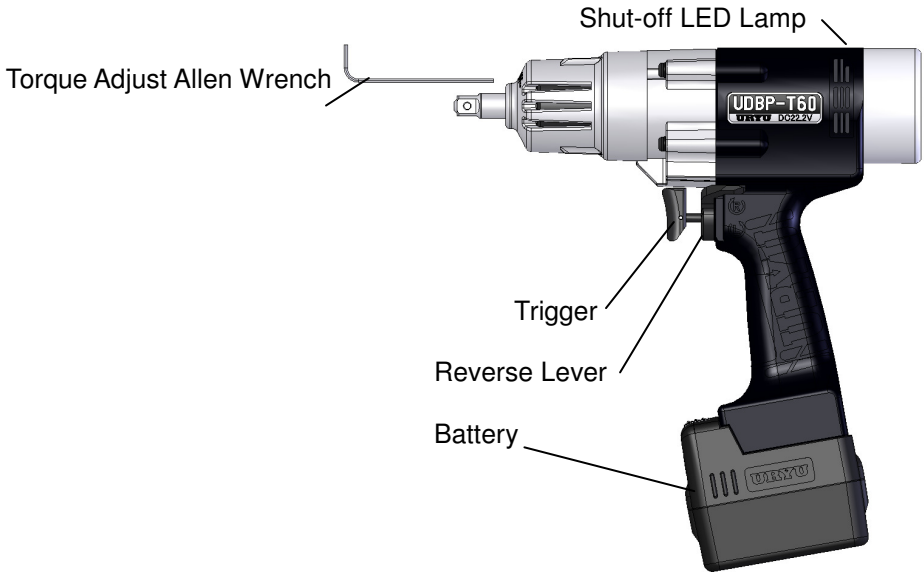

# Specifications

Model	Capacity (Nominal Bolt Size)		Torque Range		Free Speed (Approx.) rpm	Overall Length less Socket or Bit (Approx.)		Weight less Socket or Bit				From Center to Outside (Approx.)		Sq. Drive or Hex. Size		Noise Level dB(A)	Battery Voltage (Capacity)	Battery Model Number
	mm	in	Nm	ft-lbs		mm	in	with battery		with no battery		mm	in	mm	in			
								kg	lb	kg	lb							
UDBP-T40	5	13/64	4.5 - 8	3.3 - 5.9	4800	208	8 3/16	1.4	3.08	1.11	2.44	29.5	1 5/32	6.35Hex	1/4Hex	75	11.1V(1.5Ah)	UB111Li
UDBP-T50	6 - 8	1/4-5/16	6.5 - 13	4.8 - 9.6	4800	208	8 3/16	1.4	3.08	1.11	2.44	29.5	1 5/32	6.35Hex	1/4Hex	76	11.1V(1.5Ah)	UB111Li
UDBP-T50(P)	6 - 8	1/4-5/16	7 - 15	5.1 - 11.1	4800	205	8 5/64	1.4	3.08	1.11	2.44	29.5	1 5/32	9.5 sq.	3/8 sq.	76	11.1V(1.5Ah)	UB111Li
UDBP-T60	8	5/16	13 - 26	9.6 - 19.2	4800	223	8 25/32	1.7	3.74	1.25	2.75	29.5	1 5/32	6.35Hex	1/4Hex	77	22.2V(1.5Ah)	UB222Li
UDBP-T60(P)	8	5/16	15 - 28	11.1 - 20.7	4800	220	8 11/16	1.7	3.74	1.25	2.75	29.5	1 5/32	9.5 sq.	3/8 sq.	76	22.2V(1.5Ah)	UB222Li
UDBP-T70(P)	8 - 10	5/16-13/32	26 - 47	19.2 - 34.7	4800	234	9 7/32	2.0	4.4	1.39	3.06	29.5	1 5/32	9.5 sq.	3/8 sq.	76	33.3V(1.5Ah)	UB333Li

Ambient temperature: 0~40°C

Rotating speed change: 3 steps

Slow speed: 500rpm→1,000rpm for socket and bolt entry and tentative fastening

Free speed: 4,800rpm for regular fastening

# Handle Controls

## 1 Select rotating direction (factory supplied lever orientation)

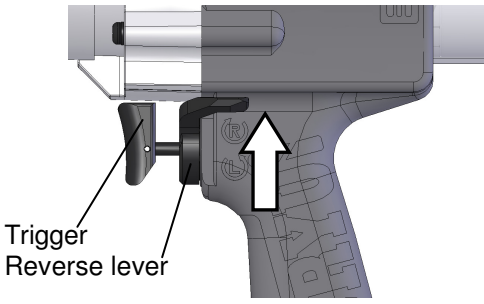

Set LEVER to R: Forward

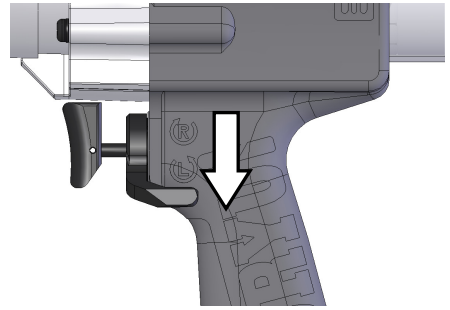

Set LEVER to L : Reverse

## 2 Press trigger

- 1) Speed increases in 3 steps as you press the trigger progressively for both forward and reverse.
- 2) Release your finger from the trigger, and the brake will work to stop the tool.

## 3 Fastening

- Fastening torque does not reach preset torque if you release trigger prior to automatic shut-off.
- Do not cover slit when the tool is in use. Doing so will restrict tool ventilation.
- Temperature protection

The tool will stop rotation with shut-off LED lamp lighting in red when the temperature gets high. Do not use the tool for approximately 30 minutes. Confirm the temperature has cooled. Restart after the temperature has reached room temperature.

### Guideline of temperature protection

Temperature protection will implement if duty cycle is greater than fastening 6 fasteners with a max 0.4 seconds fastening time on B-joint fasteners.

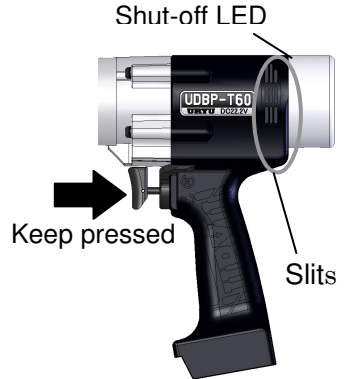

### SHUT-OFF LED LAMP

LED	Status
Green	OK
Red	Protected

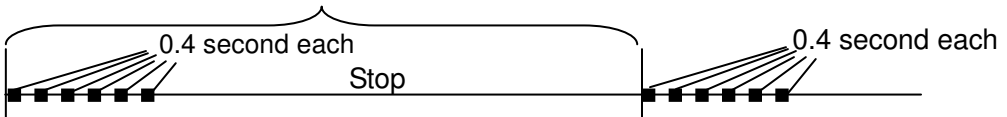

## Handling point

### 4 Torque adjustment in forward rotation (CW) only

- Release hands from trigger, then remove the battery from the tool.
- Insert an allen key in the hole to adjust relief valve as follow.
- Never touch oil plug. Removal of oil plug will result in leakage and tool requiring service.

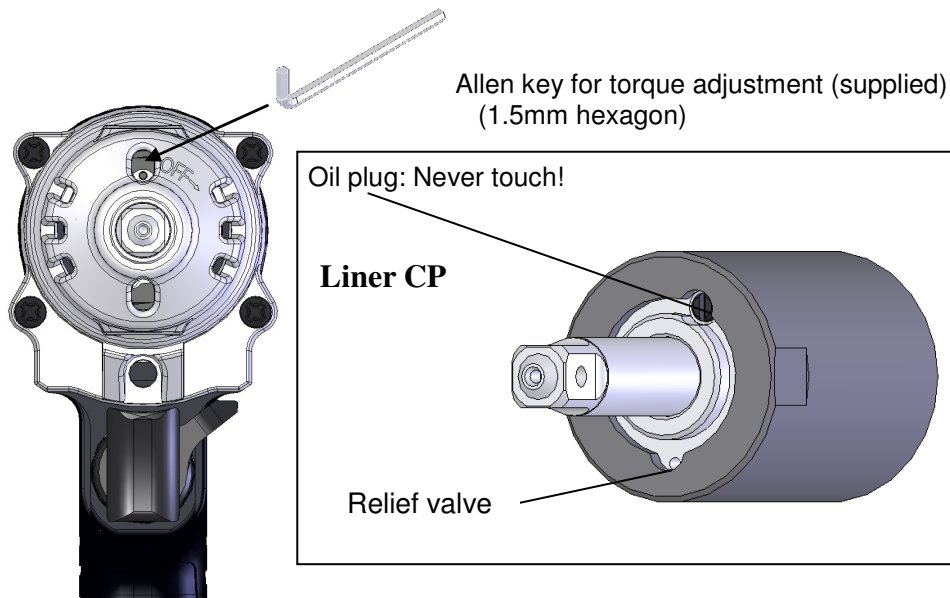

## Handle Operation

### 5 Changeable Fwd/Rev Lever (if desired)

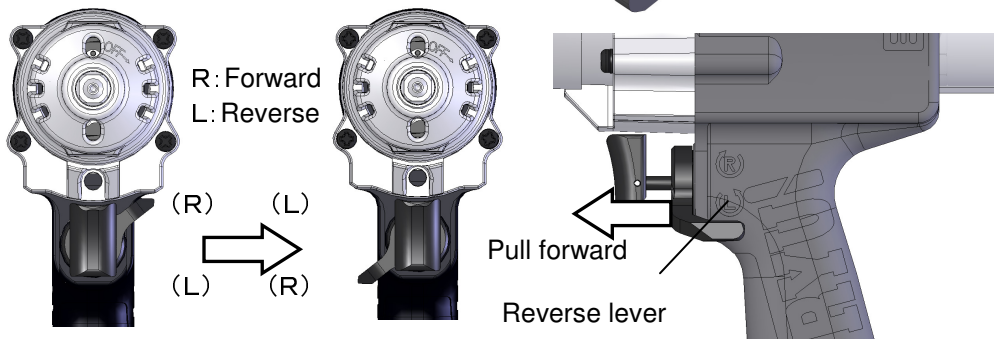

- 1) Remove allen bolt (use 2mm hexagon bar spanner).
- 2) Pull reverse lever forward to remove it.
- 3) Change the position and push it back to the tool.
- 4) Put glue (#221 LOCTITE is recommended) to thread of allen bolt and fix reverse lever to the tool by fastening the allen bolt by fastening torque 0.3~0.5Nm.

### 6 Battery gauge LED

Battery gauge LED will light for about 3 seconds first and then indicate the remaining capacity when you press the trigger or attach the battery to the tool.



Battery gauge LED

Battery gauge display while in use	
Capacity (%)	LED
Less than 10	Maintains red lamp lighting after shut-off, and goes off
10~20	Red
21~40	Yellow
41~100	Green
Battery error	Red and yellow by turns

### Battery

Model Number	UB111Li	UB222Li	UB333Li
Voltage	11.1V	22.2V	33.3V
Capacity	1.5Ah	1.5Ah	1.5Ah
Weight (Approx.)	0.29Kg	0.45Kg	0.61Kg

## Handling point

7 Press the trigger and the LED will light in white.



**CAUTION** Avoid staring at LED.

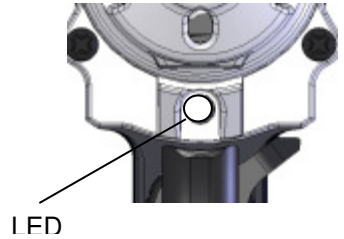

### 1 Factors that affects fastening torque

Fastening torque can change even for the same size bolt because of torque coefficient determined by finishing status of the bolt or the work such as industrial quality ranking of the bolt or the length.

### 2 Socket and anvil clearance

Use of worn or poorly engaging sockets will result in inaccurate torque delivery and potentially damage the tool. It is highly recommend to use **Ergo Drive™** sockets and accessories with these tools.

### 3 Trigger

Press the trigger firmly to operate the tool until the tool automatically shuts off.

# Battery charger

UDBP utilizes lithium ion battery.

## 1 Battery replacement interval

- Batteries may be charged up to 500 times after full discharge. This number of times can change depending upon the operating conditions. Consider that the battery has come to an end and replace with a new one when number of fasteners per full charge gets about a half of new battery condition.

## 2 Storage of battery

- Make sure to do full charge of the battery when you have not used the battery for a long time. Leaving the battery with less than 10% remaining capacity for long time can damage electrodes and damage the battery.
- Maintain storage temperature below 40°C. Storage above 40°C can accelerate deterioration.

## 3 Recycle of battery

- Lithium ion battery is a precious and recyclable resource. Recycle battery in your country in compliance with your local recycle system and the law.

## 4 Safety of battery



### CAUTION

Our battery has passed safety test in conforming to UL standard 1642 or to IEC62133. However, do not give an excessive shock or heat to battery.

## Tightening numbers per full charge

Model	Torque(Nm)	Tester & Bolt Size	Battery Model	Tightening Numbers (Approx.)	
				Hard Joint	Soft Joint
UDBP-T40	7	UFT-6(M6)	UB111Li	Hard Joint	840
				Soft Joint	270
UDBP-T50	11	UFT-10(M8)	UB111Li	Hard Joint	580
				Soft Joint	190
UDBP-T50(P)	12.5	UFT-10(M8)	UB111Li	Hard Joint	580
				Soft Joint	190
UDBP-T60	24	UFT-10(M10)	UB222Li	Hard Joint	500
				Soft Joint	170
UDBP-T60(P)	26	UFT-10(M10)	UB222Li	Hard Joint	500
				Soft Joint	170
UDBP-T70(P)	40	UFT-16(M12)	UB333Li	Hard Joint	600
				Soft Joint	210

## Charger

Model Number	UBC
Power Supply	AC100V - AC240V*
Power Consumption	100V: 225VA
	240V: 295VA
Weight (Approx.)	1.6kg
Operating Temperature Range	5-40°C

\*Torque is set at Hard Joint. Numbrs of tightening per charge varies depending on torque level, fastener length and application.

\*Use the power cable which URYU ships with the charger.



# Troubleshooting

Check the following before you ask for repair.

## When Charging

Symptom	Potential Cause	Remedy
Waiting lamp lights	Battery is overheated	Charge only room temperature batteries
Battery error lamp lights.	Battery is damaged or at the end of it's service life	Replace the battery with a new one.

## While in Operation

Symptom	Potential Cause	Remedy
Tool Does not Run	Battery depleted	Recharge the battery.
The tool gets hot.	Tool has been overworked. Duty cycle is 6 cycles per minute on a B Joint	Allow tool to reach room temperature
Tool makes "growling" sound at slow speed	Internal magnet reaction causes noise at motor to pulse connecting part.	This is a normal condition inherent to the tool design.
Anvil stops rotating at slow speed	Motor overheat protection activated	Release trigger, allow tool to cool
Torque found lower than preset torque.	Bit or socket worn out.	Replace bit or socket with a new one.
Number of tightening cycles less then normal experience	Battery charge low or battery is at end of lifespan	Recharge battery or replace with a new one.

Should the above steps fail to remedy a problem with the tool, deliver tool to an authorized service center for evaluation

## Maintenance



- 1 Check for any loose parts, breakage, or wear of all parts prior to each use.



- 1 Maintenance
  - Casing is made of plastic. Wipe it by soft cloth. Do not use volatile liquids or wet cloth because doing so will cause deterioration/discoloration of the materials.
- 2 Store the tool in a place that remains between 0°- 40°C, is moisture free, dust free, and free from direct rays of the Sun.
- 3 Periodic inspection
  - It is Recommend to allow a trained service center to disassemble and adjust the tool every 100,000 cycles or every 3 months whichever comes earlier.

## Disassembly and adjustment, inspection, and repair



• A battery pulse tool is a precision tool. Disassembly, assembly, adjustment requires exclusive JIGS plus testers, and trained techniques. Incorrect disassembly, re-assembly or adjustment can cause not only insufficient power but also accidents. Ask for these services from an authorized service center. The maker or supplier will not be held liable for any damages caused by factors found to be the cause of faulty use or repair by users or unauthorized service providers.







**Corporate Headquarters**

10000 SE Pine Street  
Portland, OR 97216  
800-852-1368  
FAX 800-582-9015  
[www.aimco-global.com](http://www.aimco-global.com)

Ave. Cristóbal Colon 14529  
Chihuahua, Chihuahua. 31109  
Mexico  
011- 52-(614) 380-1010  
FAX 011-52-52 (614) 380-1019

Global Assembly Solutions™