



**ALPHA-T42~T62 & 45~61 and
Larger ALPHA & ALPHA-T
Air Motor, Shut-off Section, and
Angle Head Repair Manual**

Contents

	<u>Page Number</u>
1. <u>Tools Needed for Repair</u>	1
2. <u>Air Motor Repair Fixtures</u>	2-3
3. <u>Disassembly and Reassembly of the Air Motor Section</u>	
• ALPHA-45 ~ 61 & ALPHA-T42 ~ T62 - Straight & Pistol Handle	4
• Exploded View of the Air Motor: ALPHA-45 ~ 61 & T42 ~ T62	5
• ALPHA & ALPHA-T Pistol Grip Handles	6
• Exploded View of the Air Motor: ALPHA-70 ~ 180 & T70 ~ T140	7
4. <u>Disassembly and Reassembly of the Shut-off Section</u>	
• ALPHA-T42S ~ T47S & ALPHA-T42 ~ T62	8
• Exploded View of the Shut-off Valve Section: ALPHA-T42S & T47S	9
• Exploded View of the Shut-off Valve Section: ALPHA-T42 & T62	10
• ALPHA-T	11
• Exploded View of the Shut-off Valve Section: ALPHA-T70 ~ T140	12
5. <u>Repair and Adjustment of the Angle Head Pulse Tool</u>	13
6. <u>Exploded View of the Angle Head Section</u>	
• ALPHA-70C, 70CH, T70C & T70CH	14
7. <u>Recommended Maintenance</u>	15

Tools Needed for Repair

1. One Set T-handle Metric Allen Wrenches
2. Flat-Bladed Screwdrivers
3. 10 oz. Ball Peen Hammer
4. One Set Pin Punches
5. One Set O-Ring Picks
6. 6" Adjustable End Wrench
7. 12" Adjustable End Wrench
8. Medium Pair Channel Locks or Adjustable Jaw Pliers
9. Medium Honing Stone
10. 220 Grit Wet/Dry Sandpaper
11. Lap Plate
12. Loc-Tite #242
13. CFC Free Degreaser/Cleanser
14. Loc-Tite Accelerator
15. Arbor Press
16. Two Torque Wrenches: 0-200 ft. lbs. and 50-600 ft. lbs.
17. Removal of Air Motor Connector (UX-450 through UX-612)
18. Auditor Series Monitor and Transducers with UFT Joint Simulators
19. Needle Nose Pliers
20. Propane Torch
21. Teflon Seal Setter
22. Bearing Removal Jig
23. Bearing Setter

Air Motor Repair Fixtures

Fixtures for Disassembly & Reassembly of Casing Connector

Part Number	Tools Used With			
161-036-6-5	ALPHA-50(S)D	ALPHA-60(S)D	ALPHA-60(S)D	
177-036-6-5	ALPHA-60 ALPHA-61	ALPHA-T45	ALPHA-T50	ALPHA-45 ALPHA-50

Fixtures for Removal of Ball Bearing for Cylinder Rear Plate

Part Number	Tools Used With			
982-401-0-2	ALPHA-45	ALPHA-50	ALPHA-60 ALPHA-61	ALPHA-T42 ALPHA-T52 ALPHA-T62
982-402-0-2	ALPHA-T70C	ALPHA-70	ALPHA-T70C	ALPHA-T70
982-403-0-2	ALPHA-T80	ALPHA-T90	ALPHA-T100	
982-404-0-2	ALPHA-T140			

Fixtures for Removal of Ball Bearing for Cylinder Front Plate

Part Number	Tools Used With			
982-402-0-2	ALPHA-45	ALPHA-50	ALPHA-61	ALPHA-T42 ALPHA-T47 ALPHA-T52 ALPHA-T62
982-951-0-2	ALPHA-T100			
982-950-0-2	ALPHA-T70(S)(C) (CH)	ALPHA-T80 ALPHA-T90		
982-906-0-2	ALPHA-T140	ALPHA-180		

Fixtures for Pressing in of Ball Bearing for Cylinder Rear Plate

Part Number	Tools Used With			
982-401-0-1				
982-402-0-1	ALPHA-T70(S) ALPHA-T70(C)(CH)			
982-403-0-1	ALPHA-45 ALPHA-50 ALPHA-61	ALPHA-T42 ALPHA-T47 ALPHA-T52 ALPHA-T62		
982-403-0-1	ALPHA-T80 ALPHA-T90	ALPHA-T100		
982-951-0-1	ALPHA-T140			
982-203-0-1	ALPHA-180			

Air Motor Repair Fixtures (cont.)

Fixtures for Pressing in of Ball Bearing for Cylinder Front Plate

Part Number	Tools Used With			
982-402-0-1	ALPHA-45(A) ALPHA-50 ALPHA-61	ALPHA-T42 ALPHA-T47 ALPHA-T52 ALPHA-T62		
982-903-0-1	ALPHA-T70(S)(C)	ALPHA-T70(CH)		
982-950-0-1	ALPHA-T80 ALPHA-T90			
982-906-0-1	ALPHA-T140	ALPHA-180		
982-951-0-1	ALPHA-T100			

Disassembly and Reassembly of the Air Motor Section

ALPHA & ALPHA-T

1. ALPHA-45 ~ 61 and ALPHA-T42 ~ T62 - Straight & Pistol Handle

A. Disassembly

1. Remove Front Casing and Pulse Unit.
2. Remove Casing Connector if it is on the model you are working on.
3. Take a hold of the Rotor and pull the whole Air Motor from the Handle.
4. Remove the Front Plate.
5. Remove the Front Plate Bearing from the Front Plate.
6. Remove the Cylinder.
7. Remove the Blades.
8. Press Rotor out of Bearing and away from Rear Plate.
9. Remove Rear Plate Bearing from the Rear Plate.

B. Inspection of Parts for Wear

1. Inspect Blades for splitting and side wear. Replace if worn.
2. Inspect Bearings for side play and knocking. Replace if worn.
3. Inspect Cylinder for waviness. Replace if worn.
4. Inspect Plates for grooving. Light marks can be lapped out using a figure-eight motion with 220 grit sandpaper on a Lap Plate. If heavy grooving exists, replace.
5. Inspect the Rotor for any sharp edges in the Blade Slots and pitting and grooving on the Plate Surface. Light marks can be stoned with a medium oil stone. If deep markings exist, replace.
6. Thoroughly clean all parts and blow dry.

C. Reassembly

1. Grease Rear Plate Bearing. Press into Rear Plate and over the rear of the Rotor at the same time.
2. There should be a small amount of drag between the Rear Plate and the Rotor. Some adjusting may be necessary.
3. Grease Front Plate Bearing and press into the Front Plate.
4. Oil Blades and install into the Rotor.
5. Slide Cylinder down over the Rotor lining up the ports on the Rear Plate with the ports on the Cylinder.
6. Set Front Plate down over the Rotor and onto the Cylinder.
7. Holding the Rotor, slide the Air Motor into the Handle.
8. Thread the Casing Connector into the Handle; this should be torqued to 25 ft. lbs.
9. Reassemble the Pulse Unit and Front Casing onto the tool.

Exploded View of the Air Motor

ALPHA-45 ~ 61 & T42 ~ T62

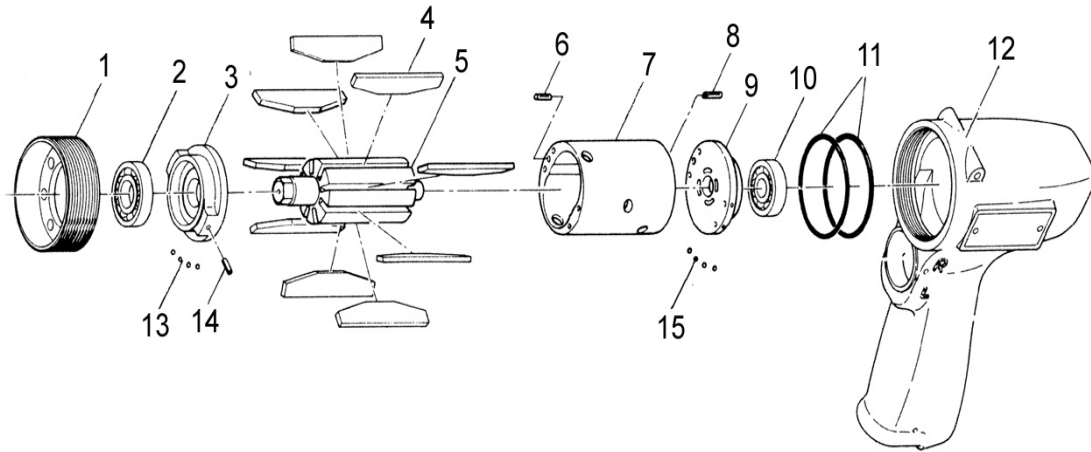

Part Number	Description	Part Number	Description
1	Casing Connector	9	Rear Plate
2	Front Plate Bearing	10	Rear Plate Bearing
3	Front Plate	11	O-Ring
4	Blades	12	Handle Casing
5	Rotor	13	Nylon Ball
6	Roll Pin	14	Roll Pin
7	Cylinder	15	Nylon Ball
8	Roll Pin		

Disassembly and Reassembly of the Air Motor Section (cont.)

2. ALPHA & ALPHA-T Pistol Grip Handles

A. Disassembly

1. Remove the Front Casing and Pulse Unit. On the T-Series, remove the Spacer and Piston Rod.
2. Remove the Head Cover and Head Cover Packing.
3. Hand Press the Air Motor out of the Casing.
4. Remove the Front Plate and the Front Plate Bearing.
5. Remove the Cylinder and Blades from the Rotor.
6. Press the Rotor out of the Rear Plate Bearing and away from the Rear Plate.

B. Inspection

1. Same as in the ALPHA-45 ~ 62 - Straight and Pistol Handle.
2. Inspect the O-Rings in the Handle for splitting or chipping and replace if necessary.

C. Reassembly

1. Grease the Rear Plate Bearing and press into the Rear Plate and onto the rear of the Rotor at the same time.
2. There should be a small amount of drag between the Rear Plate and Rotor. Some adjustment may be necessary.
3. Grease the Front Plate Bearing and press into the Front Plate.
4. Oil Blade and install into Rotor.
5. Install the Cylinder down over the Rotor and onto the Rear Plate, lining up the Port Holes and Roll Pin. Install the Front Plate bearing-side up, down over the Rotor and onto the Cylinder.
6. Install the Air Motor as an assembly into the Handle. Line up the Roll Pin on the side of the Rear Plate with the Notch in the Handle and slide the Air Motor into place.
7. Install the Head Cover Gasket, Head Cover, and the Allen head bolts. Loc-Tite all bolts with service removable Loc-Tite. Cross-tighten the bolts while rotating the Rotor with the Pulse Unit.
8. On the T-series, install the Piston Rod and Spacer.
9. Install Front Casing and Pulse Unit.

Exploded View of the Air Motor

ALPHA-70 ~ 180 & T70 ~ T140

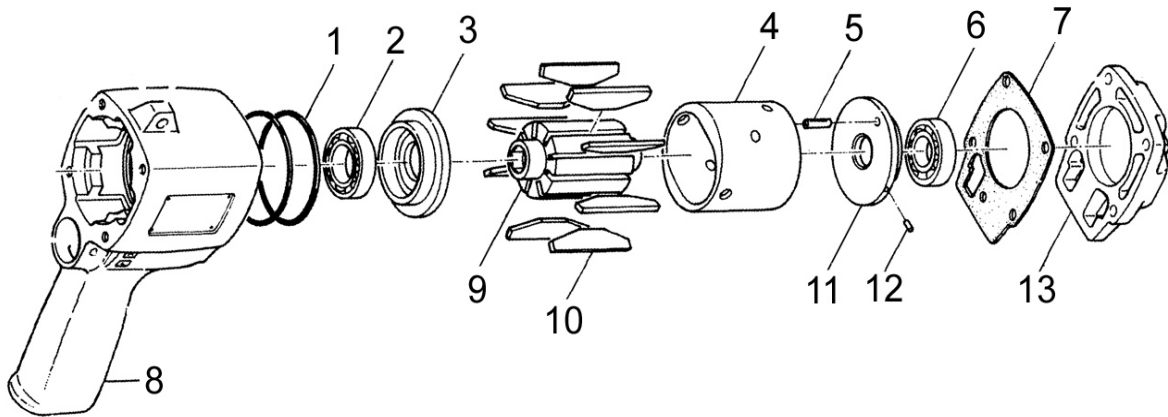

Part Number	Description	Part Number	Description
1	O-Ring	8	Handle Casing
2	Front Plate Bearing	9	Rotor
3	Front Plate	10	Blades
4	Cylinder	11	Rear Plate
5	Roll Pin	12	Roll Pin
6	Rear Plate Bearing	13	Head Cover
7	Head Cover Packing		

Disassembly and Reassembly of the Shut-off Section

ALPHA-T42S ~ T47S & ALPHA-T42 ~ T62

A. Disassembly of Shut-off Section

1. Remove the Front Casing, Pulse Unit, and Air Motor from the tool.
2. On the straight tools, remove the Reverse Lever; on the Pistol Tools, remove the Valve Plug from the side of the Handle Casing.
3. On the straight tool, remove the Rear Plate Spacer, Reverse Valve Spacer, Shut-off Valve Bushing, Ball, Spring, Shut-off Valve, Supporter Ring, and O-rings.
4. On the Pistol Tools, remove the Rear Plate Spacer, Shut-off Valve Bushing, Ball, Spring, Shut-off Valve, Spacer, Packings, and O-rings.

B. Inspection

1. **Shut-off Valve Bushing**
 - Inspect the Ball seat for oblonging. If damaged, replace.
2. **O-Ring**
 - Inspect for chipping, tears, and cuts. If damaged, replace.
3. **Packing**
 - Inspect for damage. If damaged, replace.

C. Reassembly

1. Install all O-rings.
2. On the Straight Tool, install the Ball and Spring into the back of the Shut-off Valve Bushing.
3. Install the Supporter Ring and Shut-off Valve into the Shut-off Valve Bushing.
4. Install the assembled Shut-off Valve Bushing into the Shut-off Valve Fixture with the Shut-off Valve up, lining up the threaded hole in the Shut-off Valve Bushing with the slot for the Reverse Lever and install it into the Handle Casing. Holding this in place, now install the Reverse Lever.
5. Install the Reverse Valve Spacer and the Rear Plate Spacer with the Air Motor.
6. On the Pistol Tools, install the Packing and the Spacer into the back of the Handle Casing.
7. Install the Ball and Spring into the back of the Shut-off Valve Bushing.
8. Install the Packing and Shut-off Valve into the back of the Shut-off Valve Bushing.
9. Install the Shut-off Valve Bushing Assembly into the Handle Casing. Make sure that the threaded hole in the side of the Shut-off Valve Bushing is lined up with the hole in the side of the Handle Casing and install the Valve Plug.
10. Install the Rear Plate Spacer with the Air Motor.
11. Install the Air Motor, Pulse Unit, and Front Casing.
12. You are now ready to test the tool.

Exploded View of the Shut-off Valve Section

ALPHA-T42S & T47S

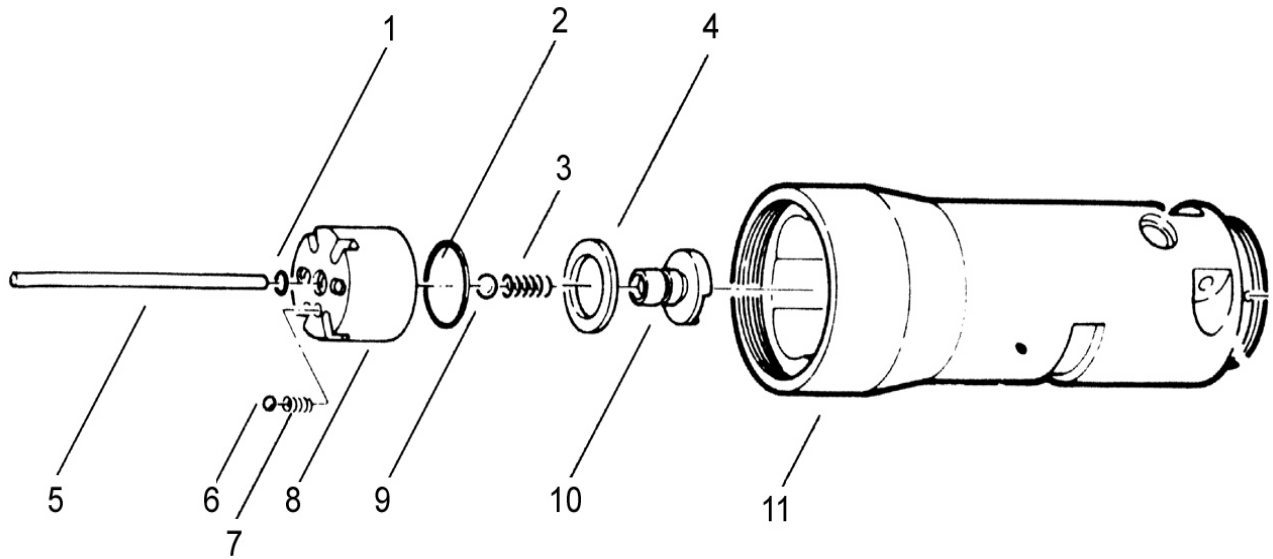

Part Number	Description	Part Number	Description
1	Piston Rod O-Ring	7	Spring
2	Shut-off Valve Bushing O-Ring	8	Shut-off Valve Bushing
3	Shut-off Spring	9	Shut-off Ball
4	Supporter Ring	10	Shut-off Valve
5	Piston Rod	11	Handle Casing
6	Ball		

Exploded View of the Shut-off Valve Section (cont.)

ALPHA-T42 ~ T62

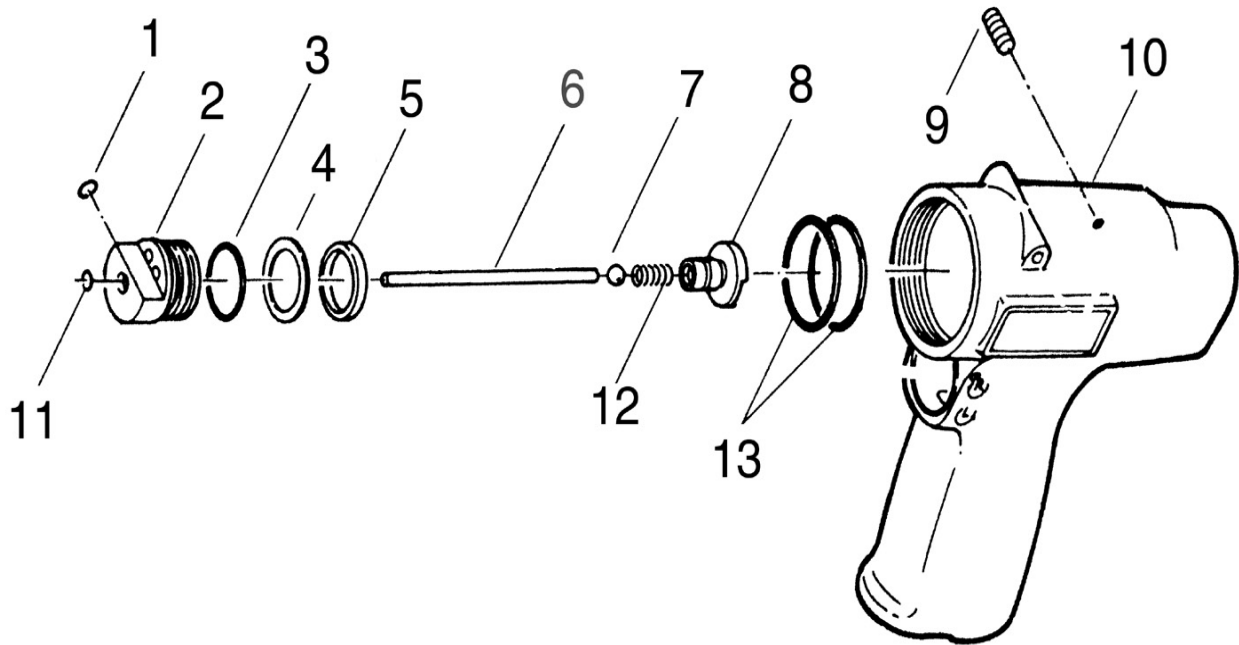

Part Number	Description	Part Number	Description
1	Valve Plug O-Ring	8	Shut-off Valve
2	Shut-off Valve Bushing	9	Valve Plug
3	Shut-off Valve Bushing O-Ring	10	Handle Casing
4	Shut-off Valve Bushing O-Ring	11	Piston Rod O-Ring
5	Supporter Ring	12	Shut-off Valve Spring
6	Piston Rod	13	Handle O-Rings
7	Shut-off Valve Ball		

Disassembly and Reassembly of the Shut-off Section (cont.)

ALPHA-T

A. Disassembly of the Shut-off Section

1. Remove the Shut-off Valve Cover using a 17mm wrench and remove the Shut-off Valve and Spring.
2. Remove the Head Cover and Head Cover Packing.
3. Remove the Piston Rod, Valve Cover, Pilot Valve Retainer, Ball, Spring, and O-rings. Some models have a Packing in the Shut-off Valve Bushing.

B. Inspection

1. O-Ring
 - Inspect for chipping, tears, and cuts. If damaged, replace.
2. Packing
 - Inspect for damage. If damaged, replace.

C. Reassembly

1. Install all O-rings and Packings.
2. Install the Pilot Valve Spring and Ball into the Head Cover.
3. Install the Pilot Valve Retainer with the small end up and the Valve Cover into the Head Cover.
4. Install the Piston Rod, Head Cover Packing, and Head Cover onto the Handle Casing.
5. Install the Shut-off Valve Spring, Shut-off Valve, and the Shut-off Valve Cover onto the Head Cover.
6. The tool is now ready to test.

Exploded View of the Shut-off Valve Section

ALPHA-T70 ~ T140

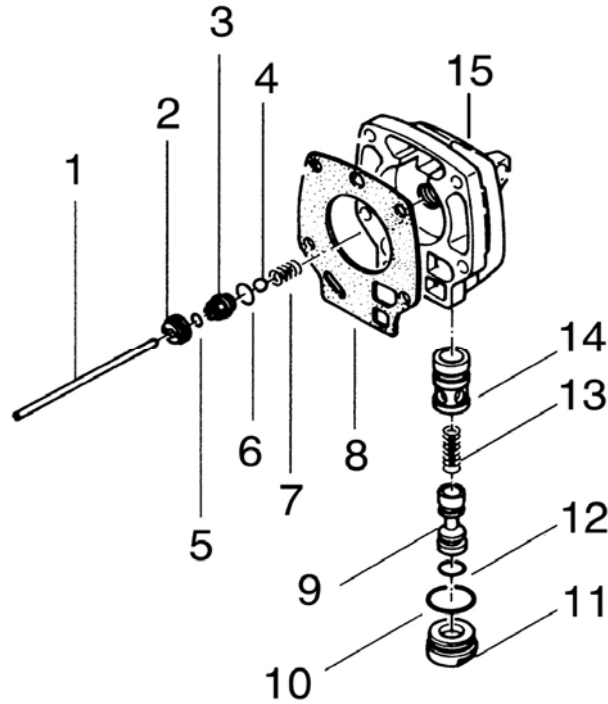

Part Number	Description	Part Number	Description
1	Piston Rod	9	Shut-off Valve
2	Valve Cover	10	Shut-off Valve Cover O-ring
3	Pilot Valve Retainer	11	Shut-off Valve
4	Pilot Valve Ball	12	Shut-off Valve O-Ring
5	Piston Rod O-Ring	13	Shut-off Valve Spring
6	Pilot Valve O-Ring	14	Shut-off Valve Bushing
7	Pilot Valve Spring	15	Head Cover
8	Head Cover Packing		

Repair and Adjustment of the Angle Head Pulse Tool

CAUTION: Read all instructions thoroughly before repairing tool.

Safety:

- Disconnect the air supply from the tool before repairing, adjusting torque, and changing sockets or extensions.
- Wear eye and hearing protection when using hammers or power tools.
- Do not wear loose clothing around power equipment.
- Dispose of all oil and grease properly.

A. Disassembly of the Angle Head

1. Remove the Front Casing Nut and remove the Angle Head Assembly from the tool
2. Remove the Angle Head Casing Cover, Driven Gear, Bushing, Spindle Spacers, and Bearings.
3. Remove the Bearing Setter Nut from inside of the Front Casing.
4. Remove the Angle Casing, Bearing Setter, Bearings, Spacers, and Driving Gear.
5. Clean all parts and inspect for wear.

B. Inspection

1. Inspect all Bearings for side play and knocking. Replace as needed.
2. Inspect Driven and Driving Gear for grooving and pitting. If present, replace as a set.

C. Reassembly

CAUTION: All shimming of the Gear Lash is performed on the Driven Gear.

1. Grease all Bearings, Driven, and Driving Gears.
2. Install the Driving Gear, Spacer, Bearings, Adjusting Spacer (if present when the tool was disassembled) and Bearing Setter into the Angle Head Casing.
3. Install the Angle Casing onto the Front Casing and secure with the Bearing Setter Nut. **Note:** Use a service removable thread locker on the Bearing Setter Nut.
4. Install the Front Casing onto the Air Motor.
5. Install the Wheel Spindle Rear Cover and Bearing into the front of the Angle Head Casing.
6. Install the Bearing onto the Driven Gear.
7. Install the Driven Gear Spindle and Driven Gear Collar into the Driven Gear.
8. Install the Driven Gear and Adjusting Spacers (quantity may vary) and tighten the Angle Head Cover so that the Driven Gear turns freely with no up and down movement. **Note:** Adjusting Spacers come in different thicknesses so be sure to order a larger quantity than needed.
9. If Driven Gear is binding, add the Adjusting Spacer; if it moves up and down too much, remove the Adjusting Spacers.

Exploded View of the Angle Head Section

ALPHA-70C, 70CH, T70C & T70CH

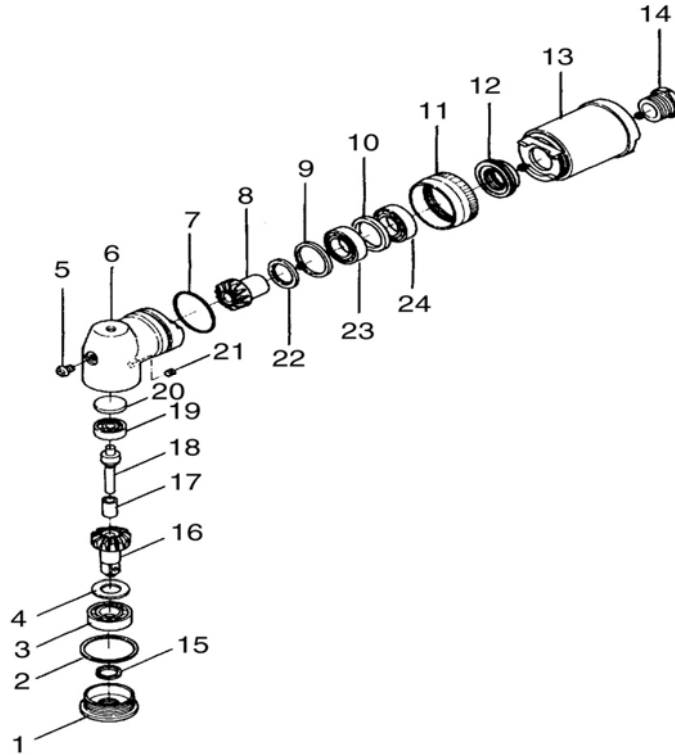

Part Number	Description	Part Number	Description
1	Angle Casing Cover	13	Front Casing
2	Angle Casing Cover Felt Ring	14	Bearing Setter Nut
3	Bearing	15	Adjusting Spacer
4	Driven Gear Spacer	16	Driven Gear
5	Hexagon Round Head Bolt	17	Driven Gear Collar
6	Angle Casing	18	Driven Gear Spindle
7	Angle Casing O-Ring	19	Bearing
8	Driving Gear	20	Driven Gear Spindle Cover
9	Adjusting Spacer	21	Allen Head Cone Point Screw
10	Driving Gear Metal Spacer	22	Driving Gear Spacer
11	Hammer Casing Nut	23	Bearing
12	Bearing Setter	24	Bearing

Recommended Maintenance

Air Motor & Angle Head Section

The Air Motor should be cleaned and inspected every 300,000 cycles or six months, whichever comes first. Replace worn parts as needed.

The Angle Head Section should be cleaned and inspected every 300,000 cycles or six months, whichever comes first. Replace worn parts as needed.

Notes



AIMCO

Corporate Headquarters

1204 E Maple Road
Troy, MI 48083
248-583-1180
FAX 248-583-7115

10000 SE Pine Street
Portland, OR 97216
800-852-1368
FAX 800-582-9015
www.aimco-global.com

Ave. Morones Prieto 2110 Pte.
Col. Loma Larga
Monterrey, NL CP 64710, Mexico
011-52-81-1001-1600
FAX 011-52-81-1001-1630

Global Assembly Solutions™