



**AIMCO**

**UAN Series  
Pneumatic Nutrunner  
Repair Manual**



---

# Contents

---

	<b><u>Page Number</u></b>
1. Tools Needed for Repair of UAN Series Pneumatic Nutrunner	1
2. Disassembly and Reassembly of Clutch (UAN 611R & 701R)	2-3
3. Disassembly and Reassembly of Clutch (UAN 830 & 950)	4-5
4. Disassembly and Reassembly of Gear Section	6-7
5. Disassembly and Reassembly of the Angle Head Section	8-9
6. Disassembly and Reassembly of the Air Motor	10-11
7. Troubleshooting and Preventative Maintenance	12

---

## Tools Needed for Repair of UAN Series

---

1. Phillips Driver #1 and #2
2. Dental Pick
3. Pin Spanner (351)
4. Needle Nose Pliers
5. Pin Punch
6. Ball Peen Hammer (8 oz.)
7. Standard Pliers
8. Snap Ring Pliers
9. Crescent Wrench
10. Lock Ring and Horseshoe Washer Pliers (Proto-P250)
11. Propane Torch (Turner Self-Lighting)
12. 471-670-7-1 Jig to Insert the Notch Pin Band on the Cam Guide
13. 517-065-4-5 Jig for Disassembly and Assembly of Driving Gear Spindle Screw
14. 268-488-6-5 Jig for Disassembly and Assembly of Angle Casing Cover for the UAN-611R & 701R-60C
15. 259-488-6-5 Jig for Disassembly and Assembly of Angle Casing Cover for the UAN-701R-30C & 40C

---

# Disassembly and Reassembly of Clutch UAN-611R and 701R

---

## **Disassembly**

1. Separate the clutch casing (left hand) from the gear casing and remove the clutch assembly.
2. Remove the regulator screw by inserting a Phillips driver between it and the stopper and turn the Phillips driver counter-clockwise to remove the regulator screw.
3. Remove the stopper being careful not to lose the pin that locks the stopper to the cam guide.
4. Remove the torque spring and spring setter from the cam guide.
5. Remove the cam rollers, cam ring, balls, and cam from the cam guide.
6. Remove the ball and spring from the cam.
7. Lift the hooked end of the notch pin band out of the hole in the cam guide and slide it around the cam guide until the end of the notch pin is exposed. Now remove the notch pin and pilot pin from the cam guide.

## **Inspection**

1. **CAM:** Inspect the cam lobes for grooving where they push the balls out against the cam ring.  
**PILOT PIN:** Inspect the shoulder that is pushed up against the notch pin for rounding.  
**NOTCH PIN:** Inspect the ends for rounding.  
**BAND:** Inspect the band. The band should set down in the groove of the cam guide so that space from the band to the outside of the cam guide is the same all the way around.  
**BALLS:** Inspect for pitting.
2. Inspect all springs for tension.
3. Replace all worn parts.

## **Reassembly**

1. Install the spring and ball into the cam.
2. If replacing the pilot pin, press the new "G" pin into the pilot pin. Install the pilot pin "G" pin out into the cam guide.
3. Install the cam into the cam guide. Rotate the cam. The lobe on the pilot pin should appear in the hole that the notch pin goes into at the same time that the lobe comes up in the slot of the cam guide. If it does not pull the cam out halfway and rotate 180°, push it back into the cam guide and try again. **Note:** The lobe on the pilot pin and the lobe on the cam need to line up.
4. Holding the cam and cam guide together, put grease into each of the slots in the cam guide.
5. Install two of the larger balls into the slot of the cam guide and put a shot of grease on top of the balls. On the 701R, install the three smaller balls. On the 611R, install the three balls of the same size on top of the two larger balls.
6. Install the cam ring over the balls and install the cam roller into the slot on the cam guide and push them down against the balls. Install the spring setter over the cam roller.
7. Install the notch pin and notch pin band. If you are replacing the band, slide the Jig #471-670-7-1 down over the cam guide and install the new band.
8. Install the torque spring, stopper, pin, and regulator screw.

# Disassembly and Reassembly of Clutch UAN-611R and 701R (cont.)

## UAN-611R & 701R Clutch

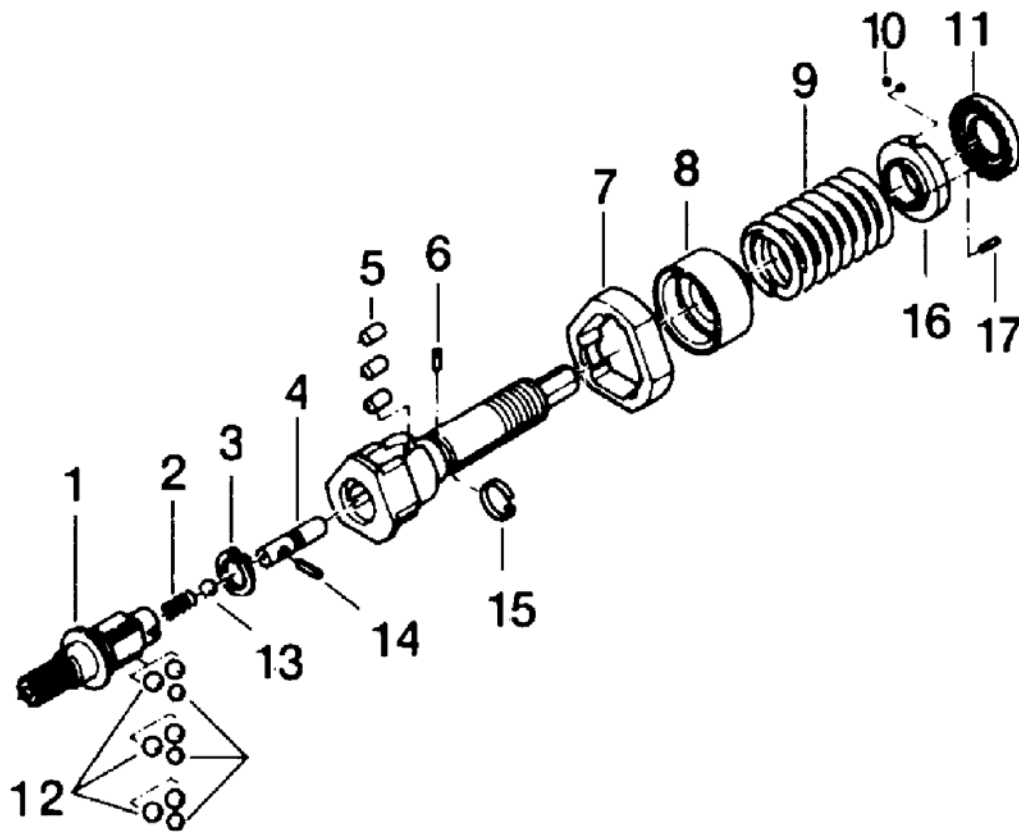

Part Number	Description	Part Number	Description
1	Cam	10	Steel Ball
2	Pilot Pin Reset Spring	11	Regulator Screw
3	Inner Snap Ring	12	Cam Balls
4	Pilot Pin	13	Pilot Pin Reset Ball
5	Cam Roller	14	G Pin
6	Notch Pin	15	Notch Pin Band
7	Cam Ring	16	Stopper
8	Spring Setter	17	Stopper Pin
9	Torque Spring		

---

# Disassembly and Reassembly of Clutch UAN-830 & 950

---

## **Disassembly**

1. Remove the gear casing from the clutch casing (right hand).
2. Locate the lock pin on the side and in the threaded portion of the clutch casing.
3. Push down on the adjusting shaft and remove the lock pin.
4. Remove the adjusting shaft, spring, cam shaft, adjusting ring, and cam setter from the clutch casing.

## **Inspection**

1. Inspect the cam shaft lobes for pitting and grooving.
2. Inspect the cam roller for pitting and grooving.
3. Inspect the cam roller pins for wear.
4. Replace all worn parts.

## **Reassembly**

1. If you replaced the cam rollers and/or cam roller pins, be sure topeen the cam setter bushing to the cam roller pins.
2. Install the cam setter (put grease on the cam rollers), adjusting ring, cam shaft, and spring into the clutch casing.
3. Thread the adjusting shaft nut onto the adjusting shaft. Now, align the cut outs on the adjusting shaft nut with the tabs on the adjusting ring and align the hole on the adjusting shaft with the hole in the clutch casing and push the adjusting shaft down into the clutch casing and install the lock pin.
4. Install the gear casing onto the clutch casing. **Note:** Use a good service removable thread locker on threaded parts.

# Disassembly and Reassembly of Clutch UAN-830 & 950 (cont.)

## UAN-830 & 950 Clutch

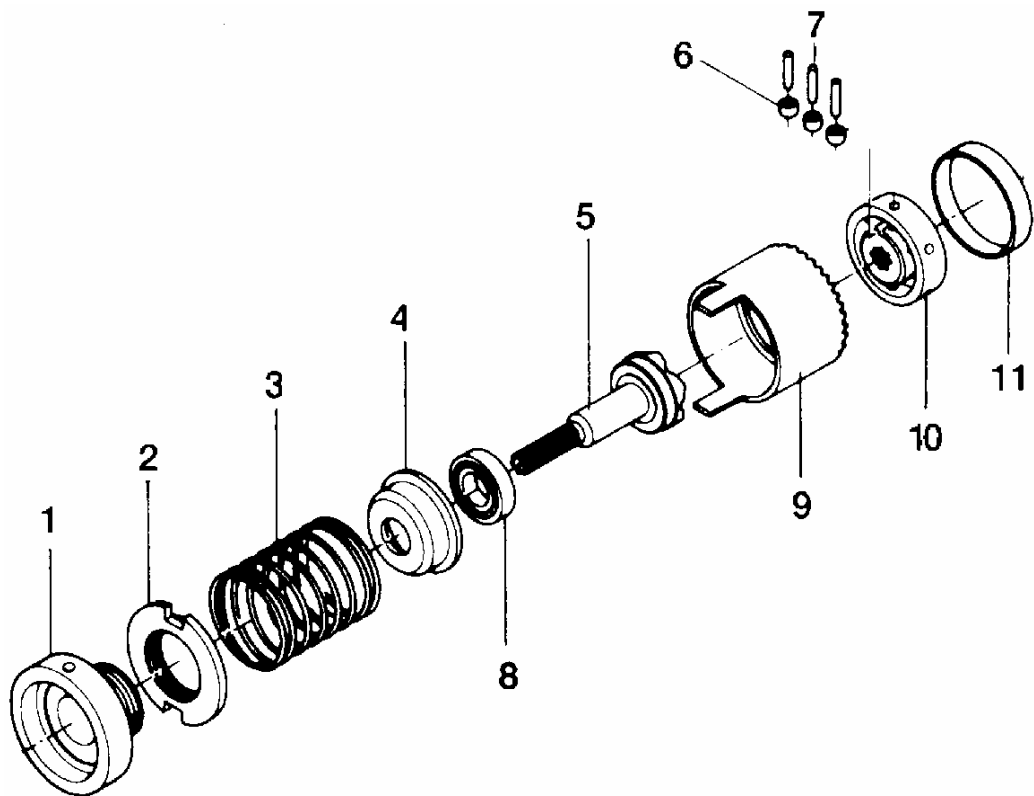

Part Number	Description	Part Number	Description
1	Adjusting Shaft	7	Cam Roller Pin
2	Adjusting Shaft Nut	8	Cam Shaft Bearing
3	Torque Spring	9	Adjusting Ring
4	Spring Setter	10	Cam Setter
5	Cam Shaft	11	Cam Setter Bushing
6	Cam Roller		

---

## Disassembly and Reassembly of Gear Section

---

### **Disassembly**

1. Using the flats on the angle casing to put your crescent wrench on, remove the second gear section (left hand).
2. Remove the clutch casing (left hand) and then remove the first gear section (right hand).
3. Now remove the snap rings, bearings, gear cases, roller pin, and planet gears from the gear casings.

### **Inspection**

1. Inspect the teeth of the gear casing, internal gear, and planet gears for pitting and grooving.
2. Inspect needle rollers for wear.
3. Inspect bearings for side play and knocking.
4. Replace all worn parts.

### **Reassembly**

1. Grease all bearings, planet gears, gear casing, and internal gears.
2. Install snap rings, bearings, planet gears, needle rollers, and gear cages into gear casings and internal gears.
3. Install gear casings and internal gears on the casing and clutch casing. **Note:** Use a good service removable thread locker on all threaded parts.

# Disassembly and Reassembly of Gear Section (cont.)

## First Gear Section UAN-611R & 701R

## Second Gear Section UAN-611R & 701R

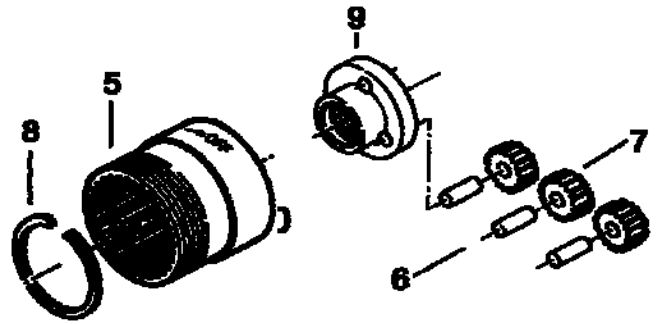
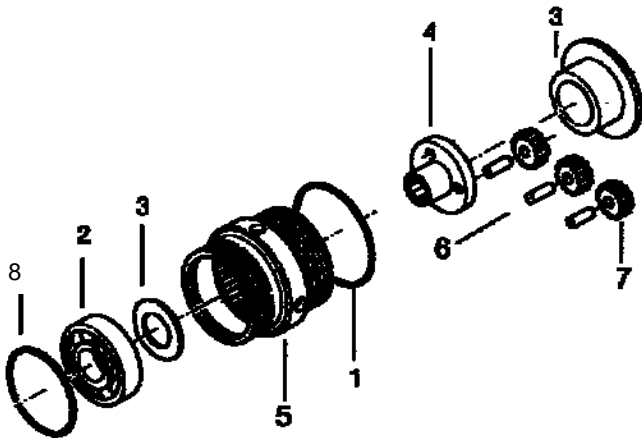

## Gear Section UAN-830 & 950

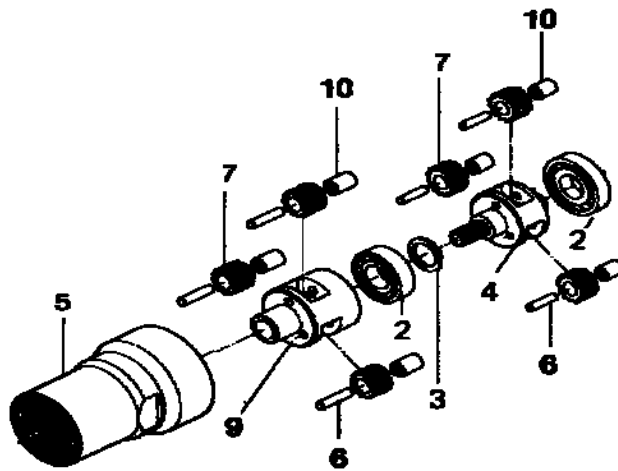

Part Number	Description	Part Number	Description
1	O-Ring	6	Needle Roller
2	Bearing	7	Planet Gear
3	Spacer	8	Snap Ring
4	First Gear Cage	9	Second Gear Cage
5	Gear Casing	10	Needle Roller Bearing

---

# Disassembly and Reassembly of the Angle Head Section

---

## **Disassembly**

1. On the UAN-611R and 701R, loosen the locking nut (right hand) and remove the angle head casing on the UAN-830 and 950. Remove the angle head casing (left hand).
2. Remove the angle head casing cover on the UAN-611R and 701R. Use Jig #268-488-6-5 to remove the angle head casing cover.
3. Remove the driving gear, bearing, adjusting spacers, and O-rings from the angle head.
4. Remove the driving gear spindle or gear cage bearing collar, bearings, spacers, bushings, and driving gear. On the UAN-611R and 701R, use Jig #517-06504-5 to remove the driving gear spindle.

## **Inspection**

1. Inspect the driver and driving gear for pitting and grooving.
2. Inspect all bearings for side play and knocking.
3. Replace all worn parts.

## **Reassembly**

1. Install the driving gear, bushings, spacers, and driving gear spindle or gear cage bearing collar. **Note:** The adjustment spacers are for adjusting the gear lash.
2. Install driving gear, spacers, O-ring, and angle head casing cover. **Note:** The adjustment spacers are used to adjust the gear lash.
3. Install the angle head casing onto tool. On the UAN-830 and 950, use a small amount of a service removable thread locker.

# Disassembly and Reassembly of the Angle Head Section (cont.)

UAN-611R & 701R

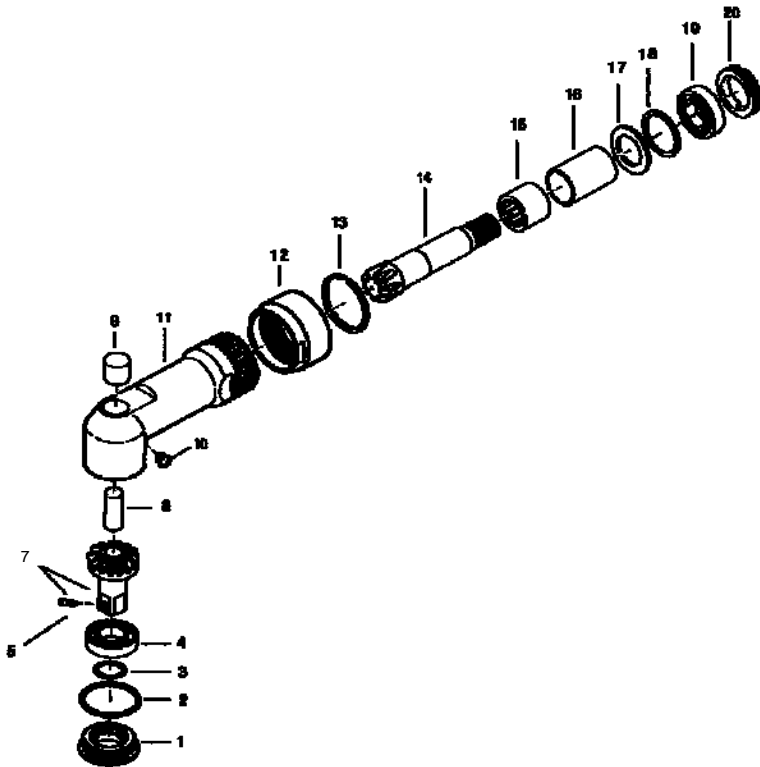

UAN-830 & 950

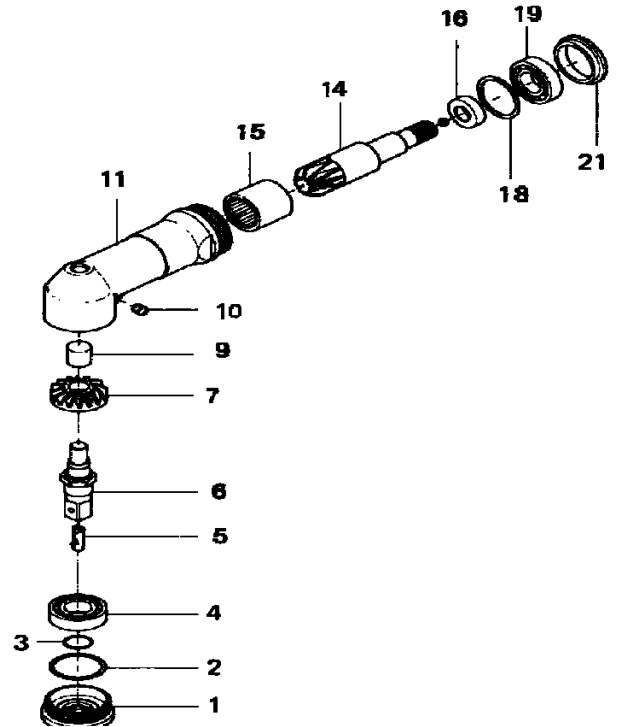

Part Number	Description	Part Number	Description
1	Angle Casing Cover	12	Locking Nut
2	Adjusting Spacer	13	Snap Ring
3	O-Ring	14	Driving Gear
4	Bearing	15	Needle Roller Bearing
5	Retainer Pin	16	Bushing
6	Anvil	17	Spacer
7	Driving Gear	18	Adjustment Spacer
8	Roller Pin	19	Bearing
9	Needle Roller Bearing	20	Driving Gear Spindle Retainer Screw
10	Grease Cup	21	Gear Cage Bearing Collar
11	Angle Casing		

---

## Disassembly and Reassembly of the Air Motor

---

### **Disassembly**

1. On the UAN-611R and 701R, separate the air motor casing and the gear casing. On the UAN 830 and 950, separate the handle casing from the air motor casing by loosening the valve body nut (right hand).
2. On the UAN 611R and 701R, pull the air motor out of the casing. On the UAN-830 and 950, the air motor slides out the back of the casing.
3. Pull the front plate off and remove the bearing.
4. Remove the blades from the rotor.
5. Press the rotor out of the rear plate bearing and remove the bearing from the rear plate.

### **Inspection**

1. Inspect bearings for knocking and side play.
2. Inspect cylinder for waviness.
3. Inspect plate for grooving.
4. Inspect blades for splitting and grooving on the sides and ends.
5. Inspect the exhaust filter for dirt.
6. Replace all worn parts.

### **Reassembly**

1. Press the greased bearing into the rear plate and over the rotor. **Note:** There should be a small amount of drag between the rotor and the rear plate but no light.
2. Lightly oil the blades and install into the rotor with the flat side out.
3. Slide the cylinder down over the rotor, lining up the roll pin with the hole in the rear plate.
4. Grease the bearing and press it into the front plate. Install the front plate onto the rotor with the bearing side up. **Note:** The cylinder should be tight between the plate, but the rotor should turn freely.
5. Slide the air motor into the casing. On the UAN-611R and 701R, line up the pin on the side of the front plate with the notch in the casing.
6. Install the gear casing or handle back on to the air motor casing.

## Disassembly and Reassembly of the Air Motor (cont.)

**UAN-611R & 701R**

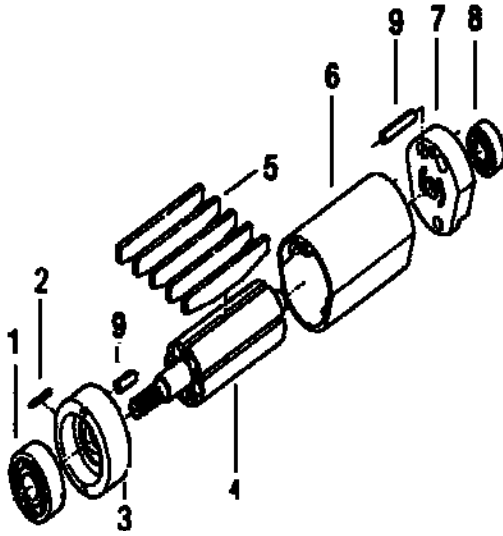

**UAN-830 & 950**

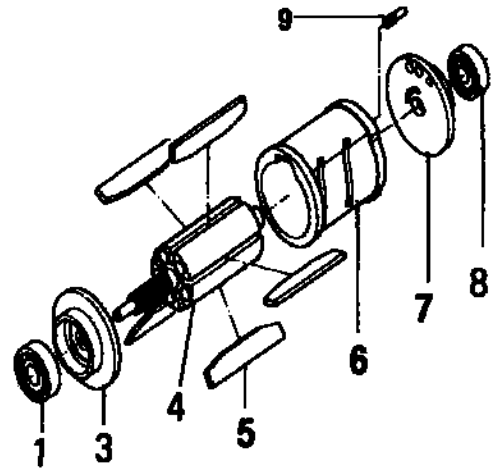

Part Number	Description	Part Number	Description
1	Bearing	6	Cylinder
2	Pin	7	Rear Plate
3	Front Plate	8	Bearing
4	Rotor	9	Roll Pin
5	Blade		

# Troubleshooting

PROBLEM	CAUSE	SOLUTION
<b>Loses torque every time the fastener is run down. Finally the tool will not run.</b>	The Lock Pin did not get put back into the Spring Retainer.	<b>Put the Lock Pin in the Spring Retainer.</b>
<b>Tool operates intermittently.</b>	One or more of the shoulders on the Pilot Pin is rounded.	<b>Replace the Pilot Pin.</b>
<b>Tool shuts off as soon as it is started or shuts off but will not re-start.</b>	Spring under Pilot Pin has lost tension.	<b>Replace the Notch Pin, Band, and/or Pilot Pin.</b>
	Notch Pin is rounded.	
	Notch Pin Band is stretched out of shape.	<b>Replace Spring.</b>
	The shoulders on the Pilot Pin are rounded.	
<b>Tool ratchets when it shuts off.</b>	Valve Rod is too long.	<b>Shorten Valve Rod.</b>
	Bur on Pilot Pin or inside of Cam.	<b>Clean bur off of Pilot Pin or Cam.</b>
<b>Loss of RPMs</b>	Exhaust Filter is dirty causing back pressure.	<b>Filter</b>
<b>Lever type only. Tool will not run.</b>	The Valve Rod is pushed through the Shut-off Valve.	<b>Replace Shut-off Valve.</b>
<b>Tool runs all the time.</b>	O-ring has gotten pushed down into the Casing.	<b>Put the O-ring back into its seat.</b>
	Air pressure is too high.	
<b>Tool will not reset.</b>	Shut-off Valve damaged.	<b>Replace Shut-off Valve.</b>
	Valve Spindle installed upside down.	<b>Reinstall Valve Spindle right-side up.</b>
<b>Tool will not reset.</b>	Shut-off Valve damaged.	<b>Replace Shut-off Valve.</b>
	Valve Spindle installed upside down.	<b>Reinstall Valve Spindle right-side up.</b>
<b>Tool will not reset after it shuts off.</b>	Pilot Pin and Cam not lined up right.	<b>Align the lobes on the Cam and Pilot Pin.</b>

## **Recommended Preventative Maintenance**

It is recommended that the whole tool be cleaned and inspected every 250,000 cycles or six months, whichever occurs first.



**AIMCO**

**Corporate Headquarters**

1204 E Maple Road  
Troy, MI 48083  
248-583-1180  
FAX 248-583-7115

10000 SE Pine Street  
Portland, OR 97216  
800-852-1368  
FAX 800-582-9015  
[www.aimco-global.com](http://www.aimco-global.com)

Ave. Morones Prieto 2110 Pte.  
Col. Loma Larga  
Monterrey, NL CP 64710, Mexico  
011-52-81-1001-1600  
FAX 011-52-81-1001-1630

**Global Assembly Solutions™**

LIT-MAN440  
Rev. 10/2006  
Printed in USA  
©2006 AIMCO