



UL Series Repair Manual

Contents

	<u>Page Number</u>
1. Tools Needed to Repair the UL Series Tools	1
2. Special Repair Fixtures for Repair of UL Series Tools	2
3. Disassembly and Reassembly of the Pulse Unit	3-5
4. Disassembly and Reassembly of the Air Motor	6-7
5. Fill & Draw Sheet	8
6. Troubleshooting and Preventative Maintenance	9

Tools Needed to Repair the UL Series Tools

1. Set of Picks
2. Standard Pliers
3. 6" Open-End Adjustable Wrench
4. 20" Open-End Adjustable Wrench
5. Hog Ring Pliers (250G Proto[®])
6. Set of Screwdrivers
7. Set of Punches
8. Dead Blow Hammer
9. 13 oz. Ball Peen Hammer
10. Three Ton Arbor Press
11. Set of V-Blocks
12. Three Ton Hydraulic Press (only needed if you are not using the PTRF-1-1)
13. Lap Plate
14. Parts Cleaning Tank
15. Wire Wheel
16. Service Removable Thread Locker (242 Blue Loctite[®])
17. PTRF-1-1 Universal Pulse Unit Repair Fixture
18. VC-101-2A Vacuum Tank
19. VCE-1-1 Vacuum Extractor
20. 1cc Glass Syringe and 0.5cc Glass Syringe
21. Pulstar Oil

Special Repair Fixtures for Repair of UL Series Tools

Description	Part Number	Tool Model
Disassembly and Reassembly of Casing Connector	143-036-0-5	UL-30 & 40
Disassembly and Reassembly of Casing Connector	147-036-2-5	UL-50 & 60
Disassembly and Reassembly of Casing Connector	143-036-8-5	UL-70
Disassembly and Reassembly of Casing Connector	115-036-3-5	UL-80
Disassembly and Reassembly of Casing Connector	147-036-8-5	UL-90
Disassembly and Reassembly of Casing Connector	148-036-2-5	UL-100
Disassembly and Reassembly of Casing Connector	130-036-2-5	UL-130
Insert of the Driving Blades	142-440-8-1, 143-440-0-0	UL-30
Insert of the Driving Blades	143-440-0-1, 143-440-0-0	UL-40
Insert of the Driving Blades	143-440-3-1, 194-440-2-0	UL-50 & 60
Insert of the Driving Blades	194-440-2-1, 194-440-2-0	UL-70
Insert of the Driving Blades	115-440-3-1, 115-440-3-0	UL-80
Insert of the Driving Blades	143-440-9-1, 143-440-9-0	UL-90
Insert of the Driving Blades	155-440-0-1, 130-440-2-0	UL-100
Insert of the Driving Blades	141-440-0-1, 141-440-0-0	UL-130
Insert of the Driving Blades	114-440-8-1, 114-440-8-0	UL-150
Anvil Sleeve for Installation of SU-Ring	143-319-0-1	UL-30, 40 & 50
Anvil Sleeve for Installation of SU-Ring	178-319-8-1	UL-60 & 70
Anvil Sleeve for Installation of SU-Ring	178-350-9-1	UL-50D & 60D
Anvil Sleeve for Installation of SU-Ring	194-319-3-1	UL-90
Repairing with the PTRF		
Disassembly and Assembly of Liner Casing Setter	PTRF-039	UL-50, 60 & 70
Disassembly and Assembly of Liner Casing Setter	PTRF-040 used with the PTRF-039	UL-90
Disassembly and Assembly of Liner Casing Setter	PTRF-041 used with the PTRF-039	UL-100
Disassembly and Assembly of Liner Casing Setter	PTRF-043 used with the PTRF-039	UL-30 & 40
Disassembly and Assembly of Liner Casing Setter	PTRF-044 used with the PTRF-039	UL-130
Repairing Without the PTRF		
Stand to Hold the Pulse Unit	143-902-0-3	UL-30 & 40
Stand to Hold the Pulse Unit	143-902-3-3	UL-50
Stand to Hold the Pulse Unit	136-905-7-3	UL-60 & 70
Stand to Hold the Pulse Unit	117-902-2-3	UL-80
Stand to Hold the Pulse Unit	143-902-9-3	UL-90
Stand to Hold the Pulse Unit	148-905-2-3	UL-100
Stand to Hold the Pulse Unit	141-902-0-3	UL-130
Stand to Hold the Pulse Unit	114-902-8-3	UL-150
Press Bar for Rear Liner Plate	196-901-4-9	UL-70
Press Bar for Rear Liner Plate	143-901-9-9	UL-80 & 90
Press Bar for Rear Liner Plate	194-901-2-9	UL-100
Press Bar for Rear Liner Plate	194-901-6-9	UL-130 & 150
Disassembly and Reassembly of Liner Casing Setter	143-906-0-5	UL-30 & 40
Disassembly and Reassembly of Liner Casing Setter	147-906-2-5	UL-50, 60 & 70
Disassembly and Reassembly of Liner Casing Setter	115-906-3-5	UL-80
Disassembly and Reassembly of Liner Casing Setter	143-906-9-5	UL-90
Disassembly and Reassembly of Liner Casing Setter	148-906-2-5	UL-100
Disassembly and Reassembly of Liner Casing Setter	130-906-2-5	UL-130
Disassembly and Reassembly of Liner Casing Setter	130-906-4-5	UL-150

Disassembly and Reassembly of the Pulse Unit

Disassembly

1. Remove the Front Casing (left-hand thread) from the tool.
2. Remove the Purple Cushion from the Pulse Unit and the Pulse Unit from the Handle.
3. Remove the Oil Fill Plug and extract all of the oil with the VCE-1-1 from the Pulse Unit.
4. Place the Pulse Unit in the PTRF-1-1 or the Stand for Holding Pulse Unit and remove the Liner Casing Setter using the PTRF-039, PTRF-040, PTRF-043, PTRF-044 or Disassembly and Assembly of the Liner Casing Setter (right-hand thread).
5. While holding the Pulse Unit with the Anvil up, tap on the Anvil with a Dead Blow Hammer to remove the Rear Liner Plate, Anvil, Driving Blades, and Driving Blade Rollers.
6. Remove the Relief Valve and Locator Pin from the Liner on the UL-60 and up. On the UL-30 ~ 50, remove the Relief Valve from the end of the Anvil and the Locator Pin from the Liner.
7. Remove all O-rings and Supporter Rings. Clean and inspect all parts. Resurface only those parts having burs on them. If any parts show deep grooving or surface wear, they will need to be replaced.

Assembly

1. You will find all O-rings, Supporter Rings, and Springs needed for rebuild of the Pulse Unit in a Pulse Unit Repair Kit (PRK). To order a PRK, you would order the model number of the tool plus dash PRK (i.e., UL-70-PRK).
2. Lubricate all O-rings with Pulstar Oil.
3. Install the O-ring and Supporter Ring on the Relief Valve using the O-ring Install Fixture and install the Relief Valve into the Liner on the UL-60 and up. On the UL-30 ~ 50, install the Relief Valve into the Anvil.
Note: Be careful not to cut the O-ring on the Relief Valve.
4. Install two Locator Pins into the Liner.
5. Install the Anvil SU-ring and Supporter Ring into the Anvil.
6. Install the Driving Blade Springs, Driving Blades, and Driving Blade Rollers into the Anvil and into the Driving Blade Install Fixture. (Notes: Chamfered end of roller goes to the front line plate.)
7. Install the Anvil into the Liner and through the Front Liner Plate removing the Driving Blade Install Fixture. As you do this, make sure to keep the Nylon piece of the Driving Blade Install Fixture tight against the Anvil.
8. Install the O-ring onto the Rear Liner Plate and install the Rear Liner Plate onto the Liner.
9. Clean the threads on the Liner Casing and Liner Casing Setter with a degreaser or Isopropyl Alcohol. Put a small amount of thread locker (i.e., Loctite 242) on the Liner Casing Setter and install into the Liner Casing.
Note: If you use Isopropyl Alcohol to clean the threads, it will cause the thread locker to set up in about 10-15 minutes.

Disassembly and Reassembly of the Pulse Unit (cont.)

10. Now, using the PTRF-1-1 and following the Fill & Draw sheet, apply the proper amount, press load to the Rear Liner Plate, and tighten the Liner Casing Setter to the proper torque. **Note:** Make sure that you use the proper Press Cap when applying the press load to the Pulse Unit.
11. Once you are sure that the thread locker has set up, make sure that the Torque Adjuster is turned all the way out counter-clockwise on the UL-60 and up. On the UL-30 ~ 40, the Torque Adjuster should be flush with the end of the Anvil. Put the Pulse Unit into the VC-101-2A Vacuum Fill Tank, making sure that the Pulstar oil is about one-half of an inch below the oil fill hole on the Pulse Unit.
12. Now, cycle the Vacuum Fill Tank. **Note:** The gauge on the tank should read 29 in.Hg. or above.
13. Now, pull the Pulse Unit out of the Vacuum Fill Tank. Tip the Pulse Unit on its side to remove the excess oil from the top of the Pulse Unit so that it is level with the top of the oil fill hole. Following the Fill & Draw sheet, remove the recommended cc's of oil from the Pulse Unit and install the Oil Fill Plug. **Note:** Make sure that you pull up lightly on the plunger of the syringe as you put the needle into the Pulse Unit. This will keep you from displacing the oil out of the Pulse Unit when you put the needle into the Pulse Unit.
14. Install the Purple Cushion onto the front of the Pulse Unit and install the Pulse Unit and Casing onto the Handle. **Note:** The torque for the front casing is 16-24 Nm.
15. You are now ready to test the tool.

Disassembly and Reassembly of the Pulse Unit (cont.)

UL Pulse Unit

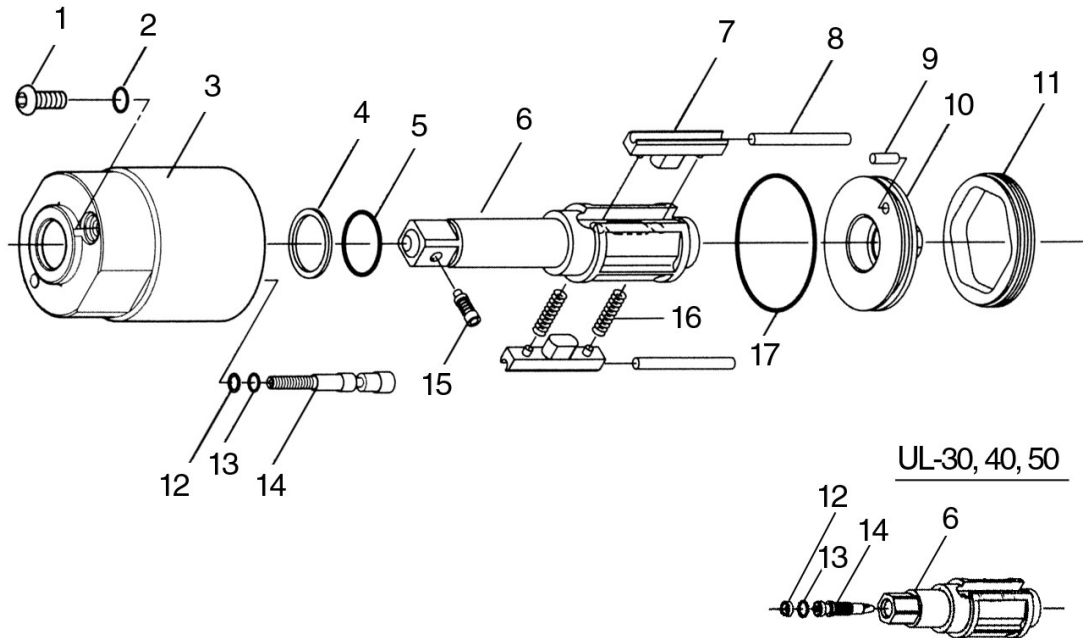

Part Number	Description	Part Number	Description
1	Oil Fill Plug	10	Rear Liner Plate
2	Oil Fill Plug O-Ring	11	Liner Casing Setter
3	Liner	12	Relief Valve Supporter Ring
4	Anvil Supporter Ring	13	Relief Valve O-Ring
5	Anvil O-Ring	14	Relief Valve
6	Anvil	15	Anvil Retainer Pin
7	Driving Blade	16	Driving Blade Spring
8	Driving Blade Roller	17	Rear Liner Plate O-Ring
9	Locator Pin		

Disassembly and Reassembly of the Air Motor

Disassembly

1. Remove the Casing (left-hand thread) and Pulse Unit from the Handle.
2. With the Casing Connector Fixture, remove the Casing Connector (left-hand thread) from the Handle.
3. Remove the Front Air Motor Plate, Rotor, Cylinder, Blades, Rear Air Motor Plate, O-ring, and Rear Plate Spacer from the Handle.
4. Remove the O-rings from inside of the Handle.
5. Remove the Bearings from the Front and Rear Air Motor Plates. The Bearing is a press fit into and over the Rotor on the Rear Air Motor Plate.
6. Clean and inspect all parts. Resurface only those parts having burrs on them. If any parts show deep grooving or surface wear, they will need to be replaced.

Assembly

1. You will find all Bearings, O-rings, Blades, and Filter needed for rebuild of the Air Motor in an Air Motor Repair Kit (RK). To order an RK, you would order the model number of tool plus dash RK (i.e., ULT-70RK).
2. Coat one-third of the Bearings with a good-quality grease (i.e., Chevron Moly Grease EP NLG1 2).
3. Press the Rear Plate Bearing into the Rear Plate and over the Rotor at the same time. **Note:** You should not be able to see any light between the Rear Plate and the Rotor and the Rotor should turn freely when you have it set right.
4. Put a light coat of air motor oil on the Blades and install them in the Rotor.
5. Put the Cylinder down over the Rotor and onto the Rear Plate with exhaust holes up.
6. Press the Front Plate Bearing into the Front Plate and install the Front Plate onto the Cylinder and Rotor.
7. Install the O-ring and Rear Plate Spacer onto the Rear Air Motor Plate.
8. Lightly oil the O-rings and install them into the Handle.
9. Line up the pin on the side of the Front Plate with the cut-out on the inside of the Handle and install the Air Motor into the Handle.
10. Install the Casing Connector into the Handle. The recommended torque for the UL-30-80 is 40-50 Nm, the UL-90 and 100 is 45-55 Nm, the UL-130 is 55-65 Nm, and the UL-150 is 60-70 Nm. Make sure to use a good service removable thread locker on the Casing Connector.
11. Install the Pulse Unit and Casing on the Handle. Make sure to use a good service removable thread locker on the Casing Connector.
12. The tool is ready to test.

Disassembly and Reassembly of the Air Motor (cont.)

UL Pulse Unit

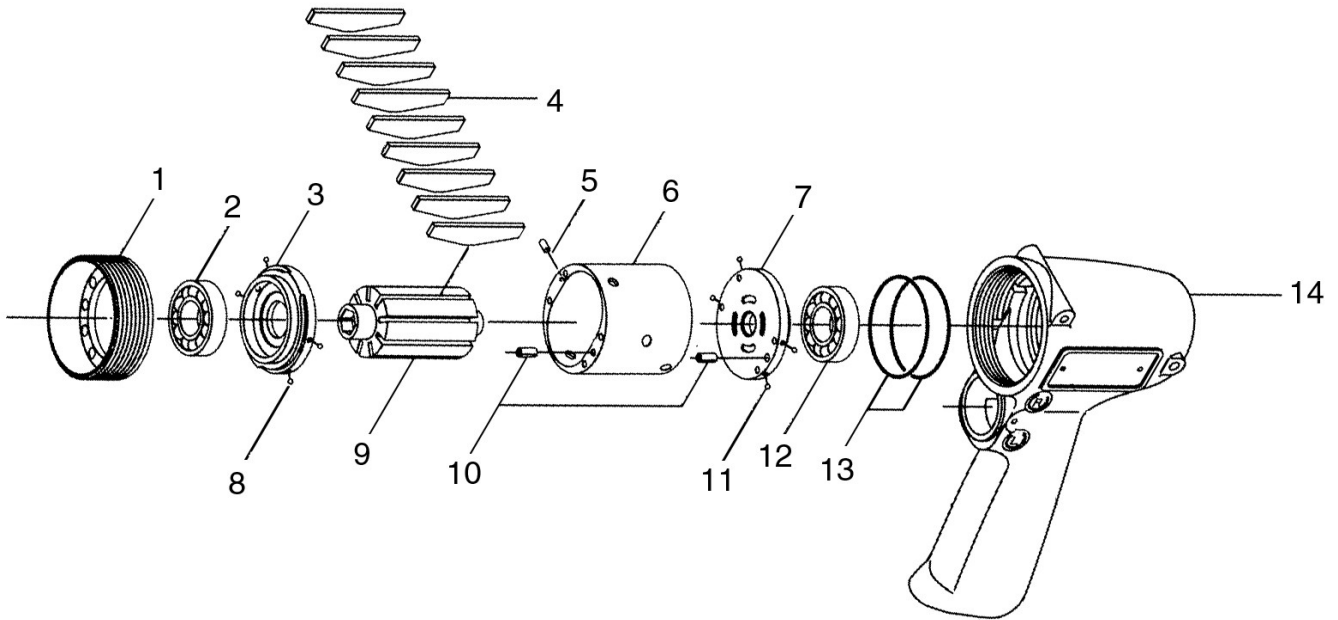

Part Number	Description	Part Number	Description
1	Casing Connector	8	Nylon Ball
2	Front Plate Bearing	9	Rotor
3	Front Plate	10	Roll Pin
4	Blade	11	Nylon Ball
5	Roll Pin	12	Rear Plate Bearing
6	Cylinder	13	O-Ring
7	Rear Plate	14	Handle

UL Series Troubleshooting

Troubleshooting

TROUBLE	CAUSE	SOLUTION
Low Torque	Air motor dry; no lubrication	Lubricate the air motor.
	Loss of power in the air motor	Reset the air motor.
	Low oil in the pulse unit	Add .10cc of oil and/or re-tank the pulse unit.
Low RPMs	Exhaust filter dirty	Replace the filter in the silencer.
	Air motor dry; no lubrication	Lubricate the air motor.
	Loss of power in the air motor	Reset the air motor.

Recommended Preventative Maintenance

It is recommended that after every 200,000 pulsing seconds or 180 days, the fluid in the tool's pulse unit be changed. At such time, it is also recommended to grease the bearings in the air motor. If the presence of water is noted, it is recommended that a small amount of oil be run through the air motor to wash out any rust residue in the air motor.

It is also recommended that after every 400,000 pulsing seconds or 365 days, that a Pulse Unit Repair Kit be installed in the pulse unit. This also allows the inspection of hard parts in the pulse unit.

Notes

Notes

Notes



Corporate Headquarters

10000 SE Pine Street
Portland, OR 97216
800-852-1368
FAX 800-582-9015
www.aimco-global.com

Ave. Cristóbal Colon 14529
Chihuahua, Chihuahua. 31125
Mexico
011-52-(614) 380-1010
FAX 011-52-(614) 380-1019