



ULT Series Repair Manual

Contents

	<u>Page Number</u>
1. Tools Needed to Repair the ULT Series Tools	1
2. Special Repair Fixtures for Repair of ULT Series Tools	2
3. Disassembly and Reassembly of the Pulse Unit	3-6
4. Disassembly and Reassembly of the Air Motor	7-8
5. Disassembly and Reassembly of the Shut-off Valve Section	9-10
6. Fill & Draw Sheet	11
7. Troubleshooting	12
8. Preventative Maintenance	12

Tools Needed to Repair the ULT Series Tools

1. Set of Picks
2. Standard Pliers
3. 6" Open-End Adjustable Wrench
4. 20" Open-End Adjustable Wrench
5. Hog Ring Pliers (250G Proto[®])
6. Set of Screwdrivers
7. Set of Punches
8. Dead Blow Hammer
9. 13 oz. Ball Peen Hammer
10. Three Ton Arbor Press
11. Set of V-Blocks
12. Three Ton Hydraulic Press (only needed if you are not using the PTRF-1-1)
13. Lap Plate
14. Parts Cleaning Tank
15. Wire Wheel
16. Service Removable Thread Locker (242 Blue Loctite[®])
17. PTRF-1-1 Universal Pulse Unit Repair Fixture
18. VC-101-2A Vacuum Tank
19. VCE-1-1 Vacuum Extractor
20. 1cc Glass Syringe and 0.5cc Glass Syringe
21. Pulstar Oil

Special Repair Fixtures for Repair of ULT Series Tools

Description	Part Number	Tool Model
Disassembly and Reassembly of Valve Cover	145-019-6-5	ULT-30D, 40, 50 & 60
Disassembly and Reassembly of Valve Cover	147-019-6-5	ULT-70 & 80
Disassembly and Reassembly of Valve Cover	147-019-8-5	ULT-90 & 100
Disassembly and Reassembly of Valve Cover	130-019-2-5	ULT-130 & 150
Disassembly and Reassembly of Valve Cover	128-019-2-5	ULT-180
Disassembly and Reassembly of Casing Connector	144-036-0-5	ULT-30D
Disassembly and Reassembly of Casing Connector	147-036-2-5	ULT-40, 50 & 60
Disassembly and Reassembly of Casing Connector	143-036-8-5	ULT-70
Disassembly and Reassembly of Casing Connector	115-036-3-5	ULT-80
Disassembly and Reassembly of Casing Connector	147-036-8-5	ULT-90
Disassembly and Reassembly of Casing Connector	148-036-2-5	ULT-100
Disassembly and Reassembly of Casing Connector	130-036-2-5	ULT-130
Disassembly and Reassembly of Casing Connector	130-036-4-5	ULT-150
	144-440-0-0	
Insert of the Driving Blades	144-440-0-1	ULT-30D
	190-440-6-0	
Insert of the Driving Blades	190-440-6-1	ULT-40, 50 & 60
	194-440-2-0	
Insert of the Driving Blades	194-440-2-1	ULT-70
	115-440-3-0	
Insert of the Driving Blades	115-440-3-1	ULT-80
	194-440-3-0	
Insert of the Driving Blades	194-440-3-1	ULT-90
	194-440-6-0	
Insert of the Driving Blades	194-440-6-1	ULT-100
	130-440-2-0	
Insert of the Driving Blades	130-440-2-1	ULT-130
	130-440-4-0	
Insert of the Driving Blades	130-440-4-1	ULT-150
	128-440-2-0	
Insert of the Driving Blades	128-440-2-1	ULT-180
Anvil Sleeve for Installation of SU-Ring	178-319-8-1	ULT-40, 50, 60 & 70
Anvil Sleeve for Installation of SU-Ring	194-319-3-1	ULT-90
Anvil Sleeve for Installation of SU-Ring	178-350-9-1	ULT-40D, 50D & 60D
TM-Type Tools		
Disassembly and Reassembly of Valve Cover	851-017-1-5	ULT-30D, 40, 50 & 60
Disassembly and Reassembly of Valve Cover	851-007-1-5	ULT-70
Disassembly and Reassembly of Valve Cover	851-011-1-5	ULT-90
Repairing With the PTRF		
Disassembly and Reassembly of Liner Casing Setter	PTRF-039	ULT-40, 50, 60 & 70
Disassembly and Reassembly of Liner Casing Setter	PTRF-040 used with the PTRF-039	ULT-90
Disassembly and Reassembly of Liner Casing Setter	PTRF-041 used with the PTRF-039	ULT-100
Disassembly and Reassembly of Liner Casing Setter	PTRF-042 used with the PTRF-039	ULT-30D
Disassembly and Reassembly of Liner Casing Setter	PTRF-044 used with the PTRF-039	ULT-130
Disassembly and Reassembly of Liner Casing Setter	PTRF-045 used with the PTRF-039	ULT-150
Disassembly and Reassembly of Liner Casing Setter	PTRF-046, PTRF-047 used with the PTRF-039	ULT-180
Repairing Without the PTRF		
Stand to Hold the Pulse Unit	144-905-0-3	ULT-30D
Stand to Hold the Pulse Unit	145-905-6-3	ULT-40, 50 & 60
Stand to Hold the Pulse Unit	194-905-0-3	ULT-70
Stand to Hold the Pulse Unit	194-905-3-3	ULT-80
Stand to Hold the Pulse Unit	147-905-8-3	ULT-90
Stand to Hold the Pulse Unit	148-905-2-3	ULT-100
Stand to Hold the Pulse Unit	194-905-4-3	ULT-130
Stand to Hold the Pulse Unit	130-905-4-3	ULT-150
Stand to Hold the Pulse Unit	128-905-2-3	ULT-180
Disassembly and Reassembly of Liner Casing Setter	144-906-0-5	ULT-30D
Disassembly and Reassembly of Liner Casing Setter	147-906-2-5	ULT-40, 50 & 60
Disassembly and Reassembly of Liner Casing Setter	147-906-6-5	ULT-70
Disassembly and Reassembly of Liner Casing Setter	147-906-3-5	ULT-80
Disassembly and Reassembly of Liner Casing Setter	147-906-8-5	ULT-90
Disassembly and Reassembly of Liner Casing Setter	148-906-2-5	ULT-100
Disassembly and Reassembly of Liner Casing Setter	130-906-2-5	ULT-130
Disassembly and Reassembly of Liner Casing Setter	130-906-4-5	ULT-150
Disassembly and Reassembly of Liner Casing Setter	128-906-2-5	ULT-180
Press Bar for Rear Liner Plate	197-901-7-9	ULT-30D
Press Bar for Rear Liner Plate	196-901-4-9	ULT-40, 50 & 60
Press Bar for Rear Liner Plate	190-901-6-9	ULT-70
Press Bar for Rear Liner Plate	143-901-9-9	ULT-80 & 90
Press Bar for Rear Liner Plate	194-901-2-9	ULT-100
Press Bar for Rear Liner Plate	194-901-6-9	ULT-130 & 150
Press Bar for Rear Liner Plate	195-901-9-9	ULT-180

Disassembly and Reassembly of the Pulse Unit

Disassembly

1. Remove the Front Casing (left-hand thread) from the tool.
2. Remove the Purple Cushion from the Pulse Unit and the Pulse Unit from the Handle. Be sure not to lose the Adjustment Spacer, Spring, and/or Operating Rod that are between the Handle and Pulse Unit.
3. Remove the Oil Fill Plug and extract all of the oil with the VCE-1-1 from the Pulse Unit. **Note:** The Oil Fill Plug on the ULT-30D is in the Rear Liner Plate.
4. Place the Pulse Unit in the PTRF-1-1 or the Stand for Holding Pulse Unit and remove the Liner Casing Setter using the PTRF-039, PTRF-040, PTRF-041, PTRF-042 or Disassembly and Assembly of Liner Casing Setter (right-hand thread).
5. While holding the Pulse Unit with the Anvil up, tap on the Anvil with a Dead Blow Hammer to remove the Rear Liner Plate, Anvil, Driving Blades, Driving Blade Rollers, Relief Valve Spring, Relief Valve Ball, Check Valve Spring, and Check Valve Ball. Now remove the Piston from the Rear Liner Plate.
6. Remove the Front Liner Plate and Liner from the Liner Casing. You can use the Anvil with a set of V-Blocks on the Arbor Press by placing the Anvil driver end-first through the Front Liner Plate and pressing on the back of the Anvil to push the Front Liner Plate and Liner out of the Liner Casing. **Note:** Always make sure that the Front Liner Plate and Liner come out of the Liner Casing as one piece or you may cause serious damage to the Liner Casing. Never push too hard on the Arbor Press. Always push the Front Liner Plate and Liner back and forth in the Liner Casing until the Front Liner Plate and Liner move freely from the Liner Casing.
7. Separate the Front Liner Plate and Liner. **Note:** On the ULT-30D, 40, 50 & 60 series tools, the Front Liner Plate is made up of two pieces: the Front Liner Plate and the Liner Casing Spacer.
8. Remove the Relief Valve Spindle (left-hand thread), Relief Valve Pin, Relief Valve, Accumulator, Accumulator Spring, and Locator Pins from the Liner.
9. Remove all O-rings and Supporter Rings. Clean and inspect all parts. Resurface only those parts having burs on them. If any parts show deep grooving or surface wear, they will need to be replaced.

Disassembly and Reassembly of the Pulse Unit (cont.)

Assembly

1. You will find all O-rings, Supporter Rings, and Springs needed for rebuild of the Pulse Unit in a Pulse Unit Repair Kit (PRK). To order a PRK, you would order the model number of tool plus dash PRK (i.e., ULT-70-PRK).
2. Lubricate all O-rings with Pulstar Oil.
3. Install the O-ring on the Relief Valve using the O-ring Install Fixture and install the Relief Valve into the Liner lining up the slot in the Relief Valve with the hole in the Liner and install the Relief Valve Pin. **Note:** Be careful not to cut the O-ring on the Relief Valve.
4. Install the Accumulator O-ring and Supporter Ring onto the Accumulator using an O-ring Install Fixture and install the Accumulator Spring and Accumulator into the Liner.
5. Install the Relief Valve Spindle into the Relief Valve and install the O-ring on the Relief Valve Spindle (left-hand thread) and Supporter Ring into the Front Liner Plate. **Note:** The Supporter Ring is not used on the ULT-40, 50 & 60.
6. Install two Locator Pins into the front of the Liner.
7. Install the Anvil SU-ring and Supporter Ring into the Front Liner Plate and install the Front Liner Plate onto the Liner. **Note:** Make sure that you work the Relief Valve Spindle O-ring up into the Front Liner Plate by turning the Relief Valve Spindle back and forth. **Note:** On the ULT-30D, 40, 50 & 60 series, you install the Liner Casing Spacer onto the Liner. Install the Front Liner Plate after the Anvil and Driving Blades have been installed into the Liner.
8. Install the Driving Blade Springs, Driving Blades, and Driving Blade Rollers into the Anvil and into the Driving Blade Install Fixture.
9. Put the proper Anvil Sleeve Fixture over the drive end of the Anvil and install the Anvil into the Liner and through the Front Liner Plate removing the Driving Blade Install Fixture. As you do this, make sure to keep the Nylon piece of the Driving Blade Install Fixture tight against the Anvil.
10. Install two Locator Pins into the rear of the Liner, the Check Valve Spring and Check Valve Ball into the back of the Anvil and the Relief Valve Ball and Relief Valve Spring into the back of the Relief Valve in the Liner.
11. Install the O-ring onto the Rear Liner Plate and install the Rear Liner Plate onto the Liner. **Note:** If the Check Valve Cover was removed from the Rear Liner Plate when reinstalling the Check Valve Cover back into the Rear Liner Plate, make sure that the hole in the side of the Check Valve Cover is 180 degrees out from the hole inside of the Rear Liner Plate, 90 degrees out on the ULT-150 and ULT-180 only, and apply a light coat of Loctite 603 to the Check Valve Cover before installing.
12. Holding the hex end of the Rear Liner Plate in a vise, install the Front Liner Plate O-ring and now install the Liner Casing over the Anvil and onto the assembly.
13. Clean the threads on the Liner Casing and Liner Casing Setter with a degreaser or Isopropyl Alcohol. Put a small amount of thread locker (i.e., Loctite 242) on the Liner Casing Setter and install into Liner Casing. **Note:** If you use Isopropyl Alcohol to clean the threads, it will cause the thread locker to set-up in about 10-15 minutes.

Disassembly and Reassembly of the Pulse Unit (cont.)

14. Now, using the PTRF-1-1 and following the Fill and Draw sheet, apply the proper amount, press load to the Rear Liner Plate, and tighten the Liner Casing Setter to the proper torque. **Note:** Make sure that you use the proper Press Cap when applying the press load to the Pulse Unit.
15. Once you are sure that the thread locker has set-up: Make sure that the Torque Adjuster is turned all the way out counter-clockwise, fill the Rear Liner Plate with Pulstar oil, and insert the Piston stepped-end down into the Rear Liner Plate. Put the Pulse Unit into the VC-101-2A Vacuum Fill Tank, making sure that the Pulstar oil is about one-half of an inch below the oil fill hole on the Pulse Unit. **Note:** The ULT-30D goes into the Tank Anvil-side down.
16. Now, cycle the Vacuum Fill Tank. **Note:** The gauge on the tank should read 29 in.Hg. or above.
17. Now, pull the Pulse Unit out of the Vacuum Fill Tank. Tip the Pulse Unit on its side to remove the excess oil from the top of the Pulse Unit so that it is level with the top of the oil fill hole. Following the Fill & Draw sheet, remove the recommended cc's of oil from the Pulse Unit and install the Oil Fill Plug. **Note:** Make sure that you pull up lightly on the plunger of the syringe as you put the needle into the Pulse Unit. This will keep you from displacing the oil out of the Pulse Unit when you put the needle into the Pulse Unit.
18. Install the Purple Cushion onto the front of the Pulse Unit. Make sure that the Adjusting Spacer, Spring, and Operating Rod are back in the Handle and install the Pulse Unit and Casing onto the Handle. **Note:** The torque for the Front Casing is 16-24 Nm for the ULT-30D ~ ULT-80, 25-38 Nm for the ULT-90 ~ ULT-150 and 13-19 Nm for the ULT-180. Apply Loctite 222 to threads on the Casing Connector.
19. You are now ready to test the tool.

Disassembly and Reassembly of the Pulse Unit (cont.)

ULT-Pulse Unit

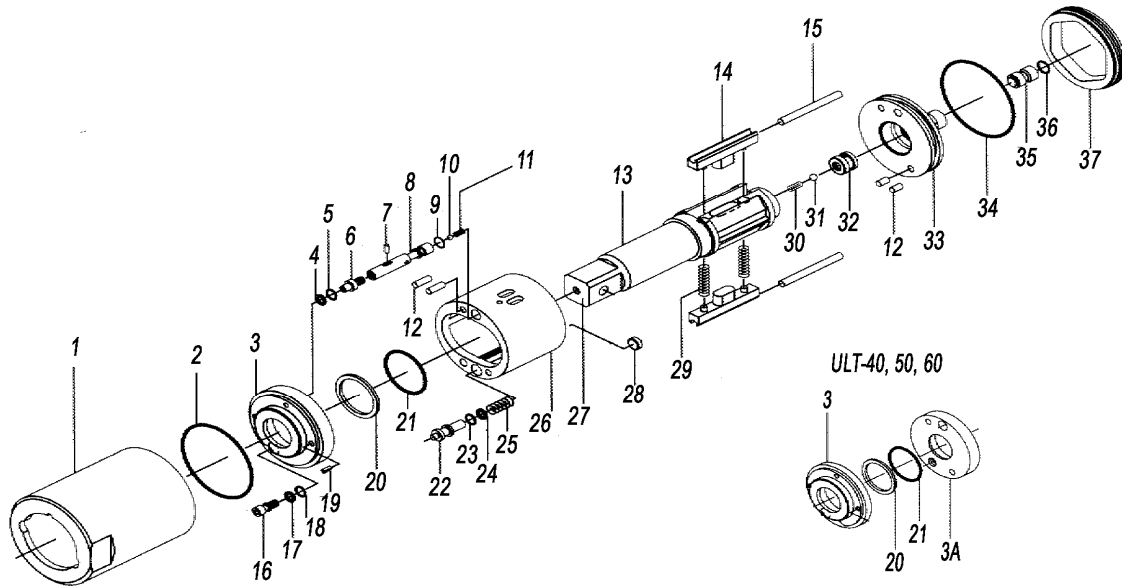

Part Number	Description	Part Number	Description
1	Liner Casing	19	Locator Pin
2	Front Liner Plate O-Ring	20	Anvil Supporter Ring
3	Front Liner Plate	21	Anvil SU-Ring
3A	Liner Casing Spacer	22	Accumulator
4	Torque Adjuster O-Ring	23	Accumulator O-Ring
5	Torque Adjuster Supporter Ring	24	Accumulator Supporter Ring
6	Torque Adjuster	25	Accumulator Spring
7	Relief Valve Pin	26	Liner
8	Relief Valve	27	Anvil
9	Relief Valve O-Ring	28	Accumulator Cover
10	Relief Valve Ball	29	Driving Blade Spring
11	Relief Valve Spring	30	Check Valve Spring
12	Locator Pins	31	Check Valve Ball
13	Anvil	32	Check Valve Cover
14	Driving Blade	33	Rear Liner Plate
15	Driving Blade Roller	34	Rear Liner Plate O-Ring
16	Oil Plug	35	Piston
17	Oil Plug Supporter Ring	36	Piston O-Ring
18	Oil Plug O-Ring	37	Liner Casing Setter

Disassembly and Reassembly of the Air Motor

Disassembly:

1. Remove the Casing (left-hand thread), Pulse Unit, Spacer, Spring, and Operating Rod from the Handle.
2. With the Casing Connector Fixture, remove the Casing Connector (left-hand thread) from the Handle.
3. Remove the Front Air Motor Plate, Rotor, Cylinder, Blades, Rear Air Motor Plate, O-ring, and Rear Plate Spacer from the Handle.
4. Remove the O-rings from inside of the Handle.
5. Remove the Bearings from the Front and Rear Air Motor Plates. The Bearing is a press fit into and over the Rotor on the Rear Air Motor Plate.
6. Clean and inspect all parts. Resurface only those parts having burrs on them. If any parts show deep grooving or surface wear, they will need to be replaced.

Assembly:

1. You will find all Bearings, O-rings, Blades, and Filter needed for rebuild of the Air Motor in an Air Motor Repair Kit (RK). To order an RK, you would order the model number of tool plus dash RK (i.e., ULT-70RK).
2. Coat one-third of the Bearings with a good quality grease (i.e., Chevron Moly Grease EP NLG1 2).
3. Press the Rear Plate Bearing into the Rear Plate and over the Rotor at the same time except on the ULT-150. The Bearings on the ULT-150 are Loctited into the Front and Rear Plate with Loctite 603 and the Rear Plate and Bearing are then pressed onto the Rotor. **Note:** You should not be able to see any light between the Rear Plate and the Rotor and the Rotor should turn freely when you have it set right.
4. Put a light coat of air motor oil on the Blades and install them in the Rotor.
5. Put the Cylinder down over the Rotor and onto the Rear Plate with exhaust holes up.
6. Press the Front Plate Bearing into the Front Plate and install the Front Plate onto the Cylinder and Rotor.
7. Install the O-ring and Rear Plate Spacer onto the Rear Air Motor Plate.
8. Lightly oil the O-rings and install them into the Handle.
9. Line up the pin on the side of the Front Plate with the cut-out on the inside of the Handle and install the Air Motor into the Handle.
10. Install the Casing Connector into the Handle. The recommended torque for the ULT-30 - 80 is 45 Nm +/-5, for the ULT-90 is 50 Nm +/-5, for the ULT-100-130 is Nm 60 +/-5, and for the ULT-150 is 65 Nm +/-5. Make sure to use a good service removable thread locker on the Casing Connector.
11. Install the Operating Rod, Spring, Adjusting Spacer, Pulse Unit, and Casing on the Handle. Make sure to use a good service removable thread locker on the Casing Connector. **Note:** The torque for the Front Casing is 16-24 Nm for the ULT-30D ~ ULT-80, 25-38 Nm for the ULT-90 ~ ULT-150 and 13-19 Nm for the ULT-180. Apply Loctite 222 to threads on the Casing Connector.
12. The tool is ready to test.

Disassembly and Reassembly of the Air Motor (cont.)

ULT- Air Motor

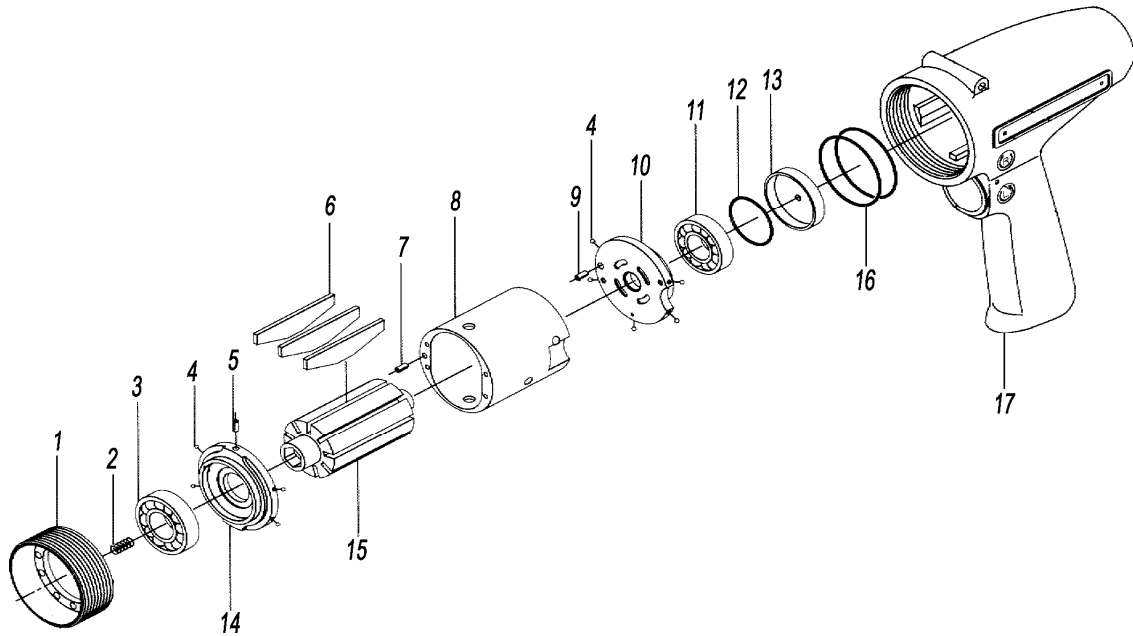

Part Number	Description	Part Number	Description
1	Casing Connector	10	Rear Air Motor Plate
2	Piston Reset Spring	11	Rear Air Motor Bearing
3	Front Air Motor Bearing	12	O-Ring
4	Nylon Ball Plug	13	Rear Plate Spacer
5	Roll Pin	14	Front Air Motor Plate
6	Blade	15	Rotor
7	Roll Pin	16	Handle O-ring
8	Air Motor Cylinder	17	Handle
9	Roll Pin		

Disassembly and Reassembly of the Shut-off Valve Section

Disassembly:

1. Remove the Valve Cover using the Valve Cover Fixture (right-hand thread) from the back of the Handle.
2. Remove the Supporter Ring, Cushion Spacer, Shut-off Valve, Supporter Ring, Shut-off Valve Spring, and Ball from the Handle.
3. Remove the Valve Plug from the side of the Handle and remove the Shut-off Valve Bushing from inside of the Handle.
4. Clean and inspect all parts. Replace all worn or damaged parts.

Assembly:

1. Lightly lubricate all O-rings and install on Shut-off Valve Bushing.
2. Install the Shut-off Valve Bushing into the Handle. Make sure to line up the hole in the side of the Shut-off Valve Bushing with the hole on the side of the Handle.
3. Install the Valve Plug snugly into place, making sure not to over-tighten the Valve Plug or you could damage the O-ring and the tool will not shut-off. **Note:** The Valve Plug should be torqued to 1.0-1.5 Nm.
4. Install the Ball, Spring, Supporter Ring, Shut-off Valve, Cushion Spacer, Supporter Ring, and Valve Cover. **Note:** The Valve Cover should be torqued to 20-30 Nm for the ULT-30D ~ ULT-80 and 30-40 Nm for the ULT-90 ~ ULT-180.
5. You are ready to test the tool.

Disassembly and Reassembly of the Shut-off Valve Section (cont.)

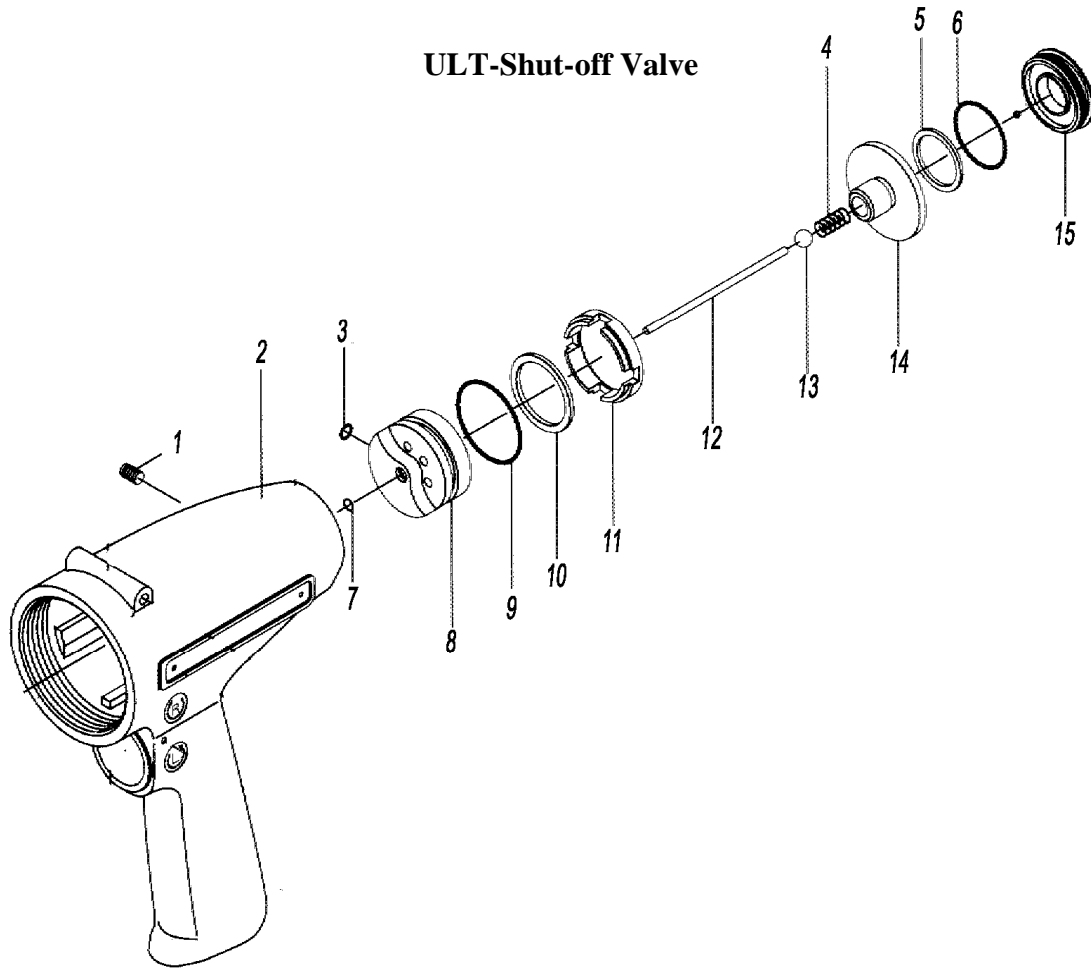

Part Number	Description	Part Number	Description
1	Valve Plug	9	O-Ring
2	Handle	10	Supporter Ring
3	O-Ring	11	Cushion Spacer
4	Shut-off Valve Spring	12	Operating Rod
5	Supporter Ring	13	Shut-off Valve Ball
6	O-Ring	14	Shut-off Valve
7	O-Ring	15	Valve Cover
8	Shut-off Valve Bushing		

ULT Series Troubleshooting

Troubleshooting

TROUBLE	CAUSE	SOLUTION
No Shut-off	Low Air Pressure	Make sure that you have 85 PSI at the tool while running the tool.
	Low Oil in the Pulse Unit	Add .10cc of oil and/or re-tank the Pulse Unit.
	Air Motor Dry; No Lubrication	Lubricate the Air Motor.
	Loss of Power in the Air Motor	Reset the Air Motor.
Premature Shut-off	Shut-off Valve Ball Pushed into Spring	Reset the Ball in the Shut-off Valve Bushing.
	Too Much Oil in the Pulse	Remove .10cc of oil from the Pulse Unit.
	Spring between the Pulse Unit and the Air Motor Weak or Missing	Replace Spring with new one or with a stronger one.
	Spacer between the Pulse Unit and the Air Motor Missing	Replace the Spacer. The Pulse Unit should only move .20mm in the Casing.
	Too Much Air Pressure	Air Pressure should be 85 PSI Dynamic.
Low Torque	Air Motor Dry; No Lubrication	Lubricate the Air Motor.
	Loss of Power in the Air Motor	Reset the Air Motor.
	Spring between the Pulse Unit and the Air Motor Weak or Missing	Replace Spring with new one or with a stronger one.
	Low Oil in the Pulse Unit	Add .10cc of oil and/or re-tank the Pulse Unit.
Low RPM's	Exhaust Filter Dirty	Replace the Filter in the Silencer.
	Air Motor Dry; No Lubrication	Lubricate the Air Motor.
	Loss of Power in the Air Motor	Reset the Air Motor.

Recommended Preventative Maintenance:

It is recommended that after every 200,000 pulsing seconds or 180 days, the fluid in the tool's pulse unit be changed. At such time, it is also recommended to grease the bearings in the air motor. If the presence of water is noted, it is recommended that a small amount of oil be run through the air motor to wash out any rust residue in the air motor.

It is also recommended that after every 400,000 pulsing seconds or 365 days, that a Pulse Unit Repair Kit be installed in the pulse unit. This also allows the inspection of hard parts in the pulse unit.



Corporate Headquarters

10000 SE Pine Street
Portland, OR 97216
800-852-1368
FAX 800-582-9015
www.aimco-global.com

Ave. Cristóbal Colon 14529
Chihuahua, Chihuahua. 31125
Mexico
011-52-(614) 380-1010
FAX 011-52-(614) 380-1019