

# Controller for Highly Reliable Fastening Tools

## UEC-4800 Instruction Manual

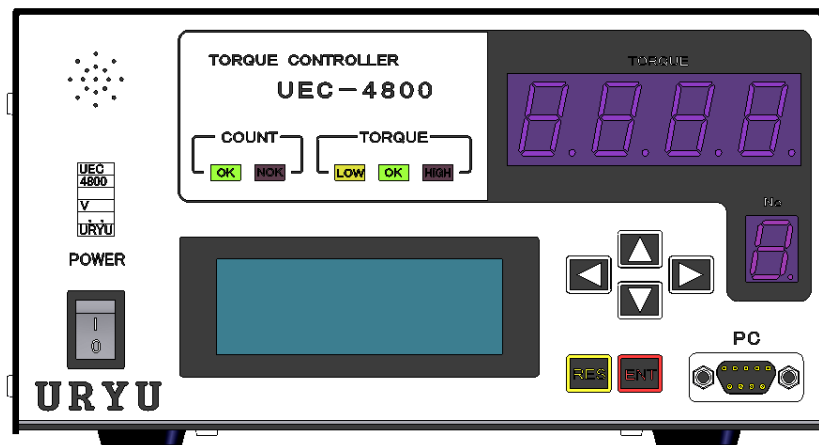

2.2 Edition

URYU SEISAKU, LTD.

## Table of Contents

1. Safety Instructions .....	2
2. Outline.....	6
2.1. Configuration.....	6
2.2. Dimentions .....	7
2.3. LCD Screen Diagram (1).....	8
2.4. LCD Screen Diagram (2).....	9
2.5. Features .....	10
2.6. Installation .....	11
2.6.1 Place.....	11
2.6.2 Conditions.....	11
3. Specifications .....	12
4. Parts names and functions.....	13
4.1. Front Panel.....	13
4.2. Rear Panel .....	14
5. Operation.....	16
5.1. Preparation.....	16
5.2. Key Operation .....	16
5.3. Setting.....	16
5.4. Self-diagnosis Function.....	17
6. IN and OUT Check.....	18
6.1. Key Check (Key Input Diagnosis).....	18
6.2. Input and Output Check (Terminal block/Tool wiring disgnosis) .....	19
7. Zero Set (Zero Point display).....	21
8. Work Number Change.....	22
8.1. Torque Polarity Change.....	23
9. Setting.....	24
9.1. BASIC (basic setting) .....	25
9.2. MODE (mode setting) .....	28
9.3. TIMER (timer setting) .....	40
9.4. DATA OUT (data output setting) .....	44
9.5. TOOL CONTROL (tool control).....	48
9.6. IN/OUT PUT (terminal block IN/OUT allocation setting)) .....	50
9.7. LAN (LAN setting).....	52
9.8. Program Number Change.....	54
9.9. MEMORY DATA (memory data) .....	56
10. Functions .....	59
10.1. Fastening Control Specifications .....	59
10.2. Upper and Lower Limit Judgement .....	62
10.3. Torque Change Degree Zone Monitor .....	63
11. Torque Sensor Wiring Diagnosis .....	65
11.1. Error Detection .....	65
11.2. ZERO/CAL Check Perform Timing.....	65
12. Auto ZERO .....	66
13. Torque Waveform Measuring Procedure .....	67
14. ANALOG OUTPUT terminal.....	68
15. Error .....	69
15.1. Error message & Contents.....	69
15.2. Recommended Action .....	70
16. Networking .....	71

## 1. Safety Instructions

Do peruse this instruction manual before installation, operation, maintenance and inspection of this system, and the use this system properly. Use this system only after you master knowledge of this equipment, safety instruction and all instructions given in the safety instructions of this system.

Take note that this operation manual classifies the safety instructions into two signs; "DANGER" and "WARNING", according to the degree of seriousness and urgency.



: A fatality and/or heavy personal injury is highly possible by improper operation. Urgent warning is essential in the event of an accident.



: A dangerous situation accompanying mid-slight personal injury and/or property damage is possible by improper operation.



sign also warns the risk of serious consequences depending on the situation. So, always follow the instructions given in this Manual.

### ◆ Installation & Surroundings



## WARNING

- Place on a metal or other incombustible component to prevent a fire.
- Keep away from the combustibles to prevent a fire.
- Avoid foreign material intrusion to prevent a fire.
- Set up controller on a site that can bear its weight to avoid personal injury from accidental falling.
- Keep the workplace well lighted and clean to avoid personal injury.
- Never wear loose-fitting clothes or dangling jewelry when using this system, and always wear the proper clothes for your job. In addition, be careful not to get your hair caught in tools, and tie long hair with a rubber ribbon or the like and wear a protective helmet to prevent personal injury.
- Securely install and fix this system to avoid personal injury in case of an emergency like an earthquake.

## ◆Wiring



# DANGER

- Be sure to turn off the power switch prior to wiring to avoid an electric shock or a fire.
- Make sure that the cords and outlets are properly grounded to avoid an electric shock or a fire.
- Carry out wiring after you installed controller to avoid an electric shock or a fire.
- Wiring must be carried out by an expert electrician to avoid an electric shock or a fire.
- Always use Y-shape crimp contact or round-shape crimp contact when wiring terminal block to avoid an electric shock or fire.



# WARNING

- Be sure that controller rated voltage agrees with AC power source to avoid personal injury and a possible fire.
- Wires must be routed and fixed properly and securely to avoid personal injury and a fire.

## ◆Handling/Operations



# DANGER

- Assurance of work-site safety by operators themselves prior to power switching operation is essential to prevent personal injury.
- Never touch switching devices with wet hands to avoid an electric shock.
- Never touch the current-carrying controllers' terminals even if the tool is not in operation to avoid electric shock.
- Never damage, excessively stress, load the cords, and never tuck them between objects to avoid electric shock.
- Be sure to turn off the controllers after each use.



# WARNING

- Make settings within the instructed setting range to avoid personal injury and burns.
- Do operations in safe surroundings while keeping proper footing. Avoid poor postures to prevent danger.
- Do operations with extra care. Never do any operation and long time continuous job due to careless and inappropriate manner to avoid personal injury or work-related diseases.

## ◆ Maintenance & Service



# DANGER

- Turn off and unplug the power cords prior to inspection/replacement to avoid an electric shock.
- Maintenance/servicing works only by an expert is allowed. Be sure to take off metal articles (wrist-watch or ring) prior to operation. Inspect cords periodically for damage, and have an expert make repairs or exchange if signs of wear or damage are noticed. Always use insulating tools at the time of servicing to avoid an electric shock and personal injury.
- Always order us or our agent for overhaul to avoid electric shock, personal injury and fire.

## ◆ Disposal



# WARNING

- Dispose your system as your industrial waste.

◆Others



# DANGER

- Never add modifications to your system to avoid an electric shock, injury or fire.
- Stop your system right away and cut off the power whenever something unusual occurs.

## General Precautions

- Some illustrations and diagrams in this Manual are shown without the safety shield materials in order to explain details. Put back the safety shield materials to the original place and operate this System in accordance to this Manual.
- Keep persons irrelevant to System operation away from work-site.
- This System is not the waterproof structure. Keep liquids away from the system. Any liquids can cause the short-out resulting in the fire or the electric shock.
- The magnet-strictive sensor is built into the UL-MC tool. Never place any magnet near the tool to avoid any magnetic field effect. Otherwise, the tool may malfunction.

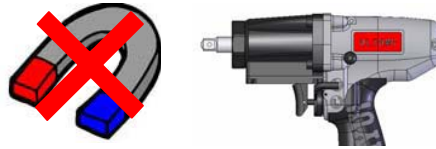

## Disclaimer

- Contents of this manual may change without notice.

## 2. Outline

### 2.1. Configuration

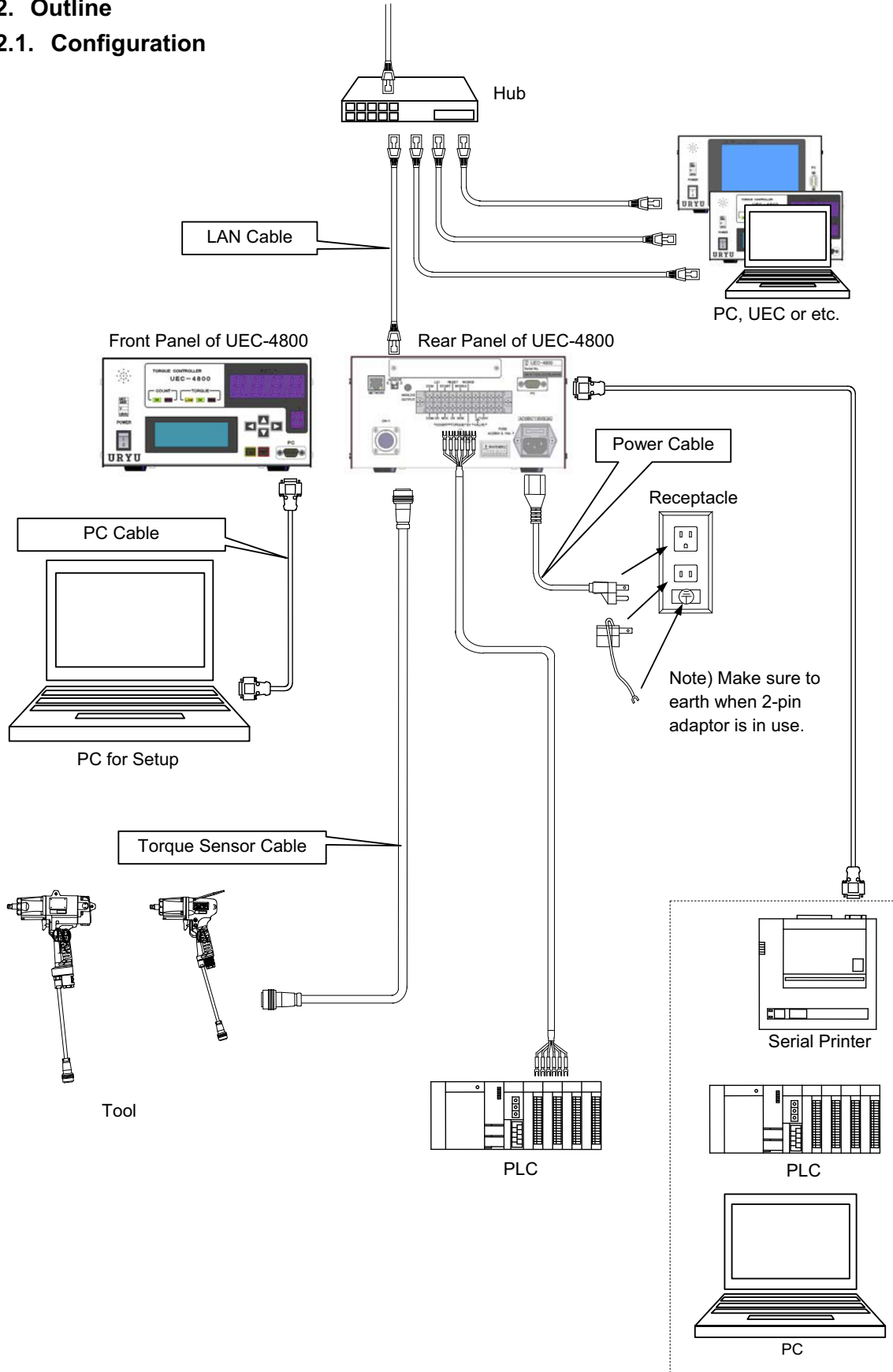

## 2.2. Dimensions

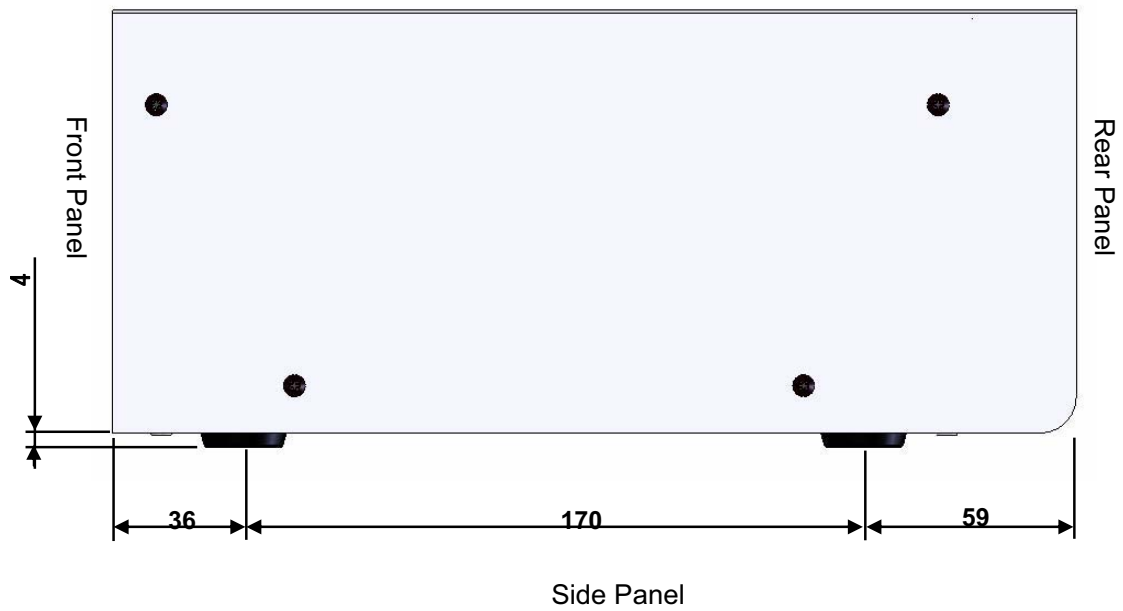
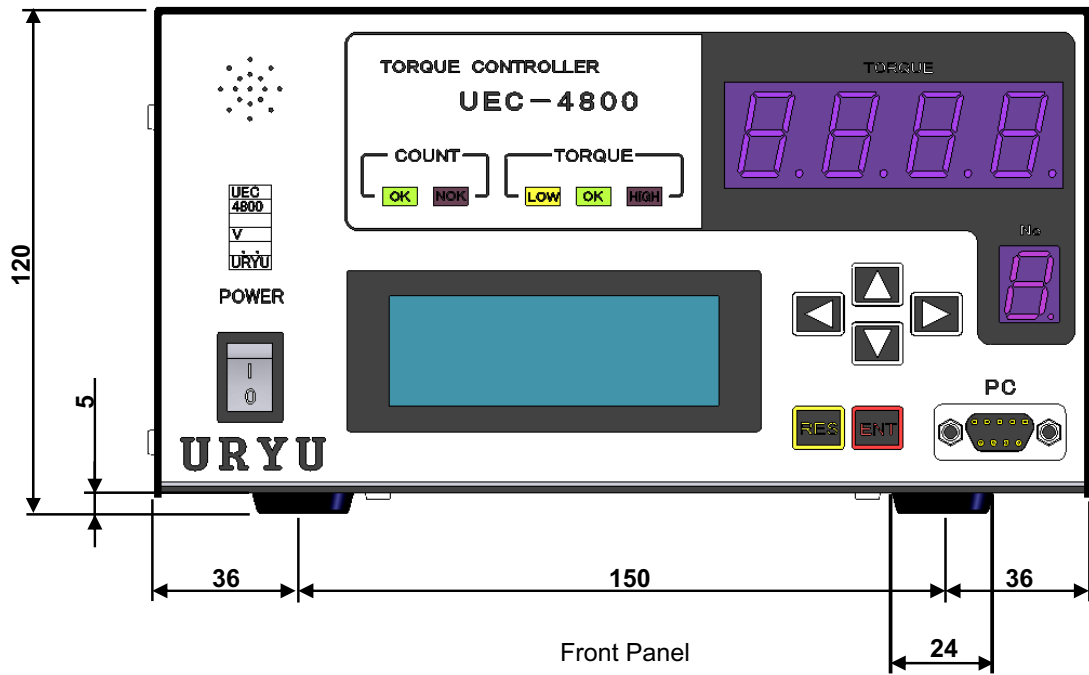

### 2.3. LCD Screen Diagram (1)

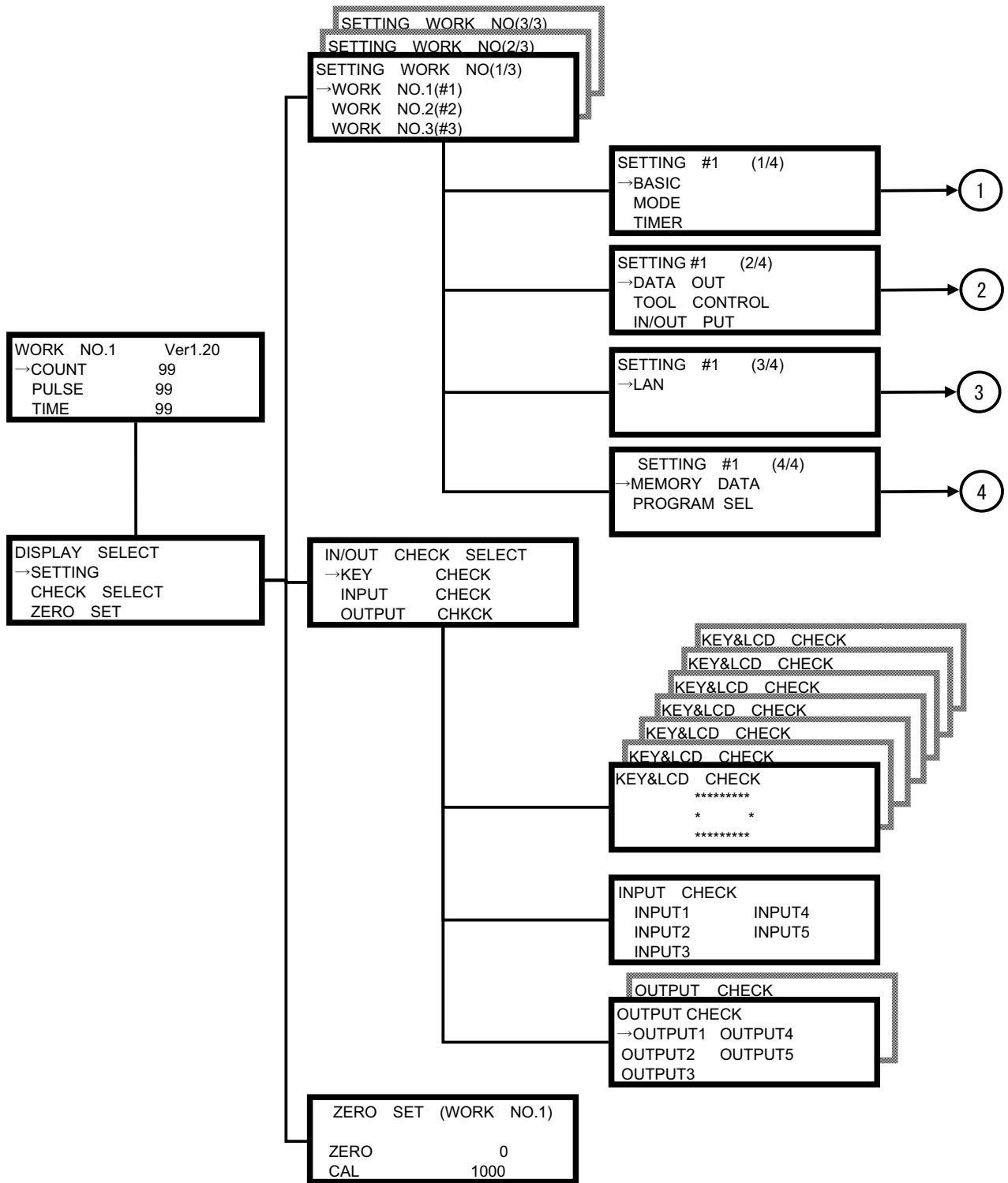

## 2.4. LCD Screen Diagram (2)

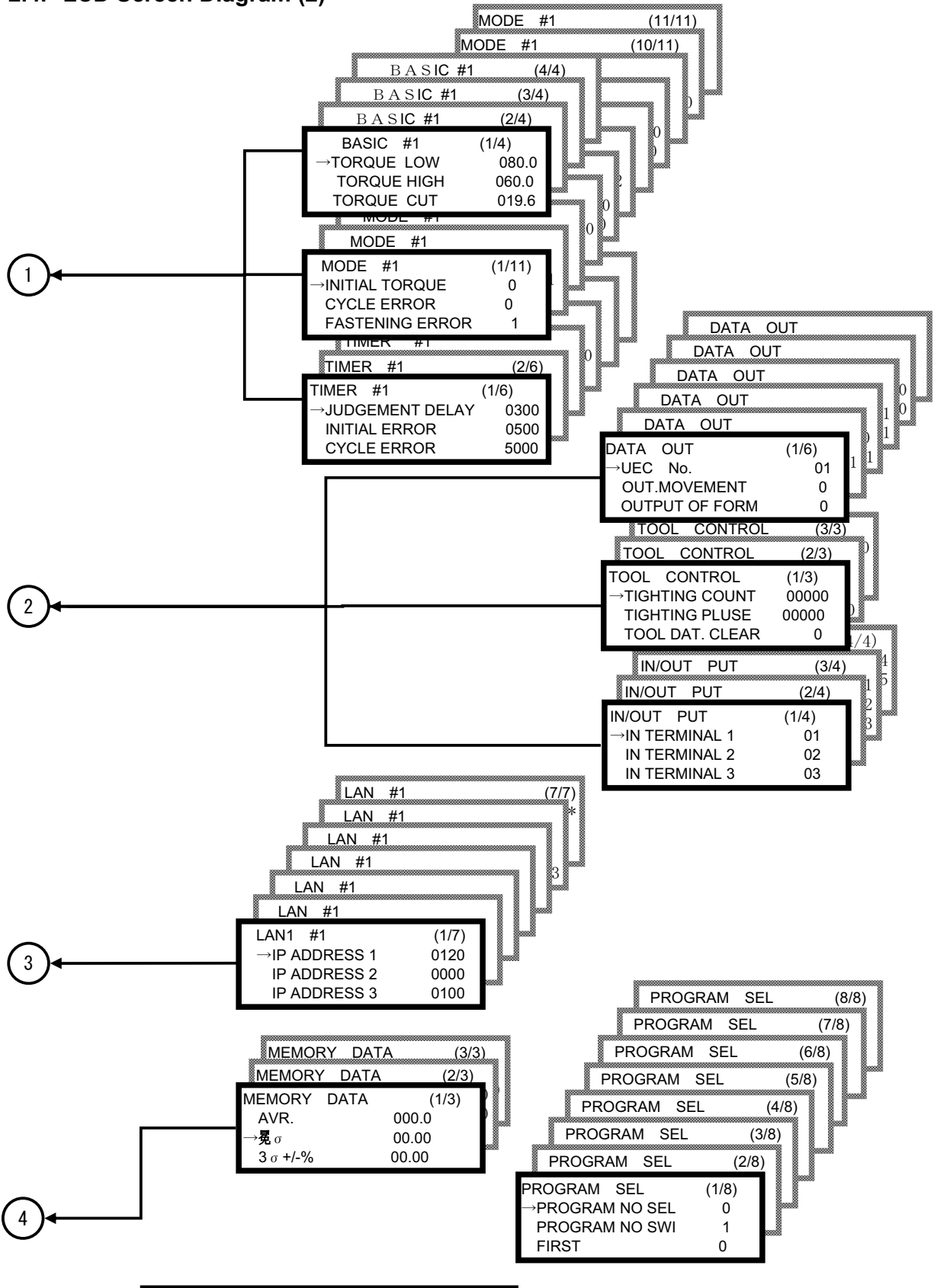

## 2.5. Features

1. Self-Diagnosis Function  
When UEC is switched on, it performs self-diagnosis by checking ROM → RAM → A/D → ZERO / CAL in a row for 10 seconds.
2. You have options of 5 fastening systems. Each system has functions of various fastening error detections and fastener number count down.
3. Controls the transducerized tools such as EC wrenches, MC wrenches, Angle Nutrunners, Open Wrenches, and Air nutrunners.
4. Makes setup or change over of fastening torque, fastener number count and other controls for maximum 8 different kinds (work 1 to 8). Fastening torque level can be changed within the same work number by using the program number change.
5. Tool's maintenance is possible by counting both total cycle numbers (how many fasteners) and/or total pulse numbers.
6. In/Output check and error messages can be checked from your PC screen or the front panel of UEC-4800 with the buzzer sounding.
7. Can set up and monitor various control values and setting values either on the front panel or on your PC screen.
8. Controls various types of torque sensors.
  - SG (Strain gauge type sensor)
    - 350Ω
    - 480Ω
    - 700Ω
  - MS (URYU Magnetostrictive type sensor)
9. Memorized maximum 12,000 pieces of fastening data without the data of day and time, and or maximum 5,400 pieces fastening data with the data of day and time.
10. Following functions are available through your PC. Please refer to the instruction manual of the UEC-4800 setup software for details.
  - Upload and receipt of the setting values
  - Fastening result data receipt and automatic storage
  - Fastening waveform data receipt and automatic storage
  - Statistic data receipt
  - I/O Check
11. Ethernet (TCP/IP) capable
  - Upload and receipt of the setting values
  - Upload of the fastening result, waveform data and the statistic data

## 2.6. Installation

Install and fix controller firmly by paying attentions to the following points.

### 2.6.1 Place

- 1) Within a building where no water or direct rays of the sun enters because UEC-4800 is not the waterproof structure.
- 2) Place where UEC-4800 does not suffer from corrosives, flammable gas, grinding fluid, oil mist, metal powders, and etc.
- 3) Well-ventilated place with less moisture, dust or waste.
- 4) Less vibration place
- 5) Place where you can disconnect power cord from power socket immediately when anything unusual occurs to UEC-4800.
- 6) Set in a dust-free box in case of use under environment of contamination degree 3.

### 2.6.2 Environmental Conditions

Item	Conditions
Place	Indoors only
Operation temperature	0 – 50 degree (no freeze)
Humidity	90% RH or less (no dew)
Preservation Temperature	0 – 50 degree (no freeze)
Preservation Humidity	90% RH or less (no dew)
Vibration	5.6 m/s <sup>2</sup> or less (10 – 60 Hz)
Altitude	Less than 1,000 m above sea level
Over voltage Category	Category III * <sup>1</sup>
Contamination Degree	Degree 2

\*1 Above categorization is of the over voltage category (I, II or III), and contamination level (1, 2, 3) as per IEC664. UEC-4800 has been categorized as the over voltage category III and the contamination degree 2 as per the above.

Note : IEC International Electric Standard Committee

### 3. Specifications

Items	Descriptions	
Power source	AC100 – 240V ± 10%	
Frequency	50 / 60Hz	
Anti-noise	1000V 1μS (by noise simulation)	
Insulation resistance	DC500V Greater than 10MΩ	
Consumption	About 30VA	
Weight	About 3.4kgs (UEC-4800TP Touch panel type : about 3.6kgs.)	
Dimensions	265 (D) x 222 (W) x 120(H)	
Main Functions	Torque control, Torque monitor Fastener number count	
Setup	From Front Panel	
	By PC (exclusive URYU setup software, common for UEC-4800/4800TP and and UECD-4800/4800TP Electric driver integrated type, is necessary.)	
Display	Torque resolution ±2048 (12 bit by A/D use)	
	LCD type	Touch Panel Type
	LCD ( 20 letters x 4 lines ) Work number, Bolt count number, Tightening time and Pulse blow number displayed <u>1-digit Digital Display (DPM)</u> Work number displayed <u>4-digit Digital Display (DPM)</u> Torque reading and Error message displayed	320 x 240 dot ( 25 letters x 15 lines – in case of Japanese two-byte character)
Lamp (LED)	Total Lamp (for Count Judgement) : OK (green) / NOK (red)	
	Torque Lamp (for Torque Judgement) : LOW (yellow) / OK(green) / HIGH(red)	
Terminal Block	Input	Operation Voltage/Current : DC24V / about 10mA 5 terminals available (free format) Note: Contact input necessary
	Output	Contact Capacity : DC30V, 1A 5 terminals available (free format), VALVE
Oscillograph output	Plug Size: JIS C6560 single small head plug φ 3.5 x 15 UEC outputs filter-processed torque waveform from analog jack Cable: UK-PLUG (Part Number: 909-483-0)	
Key	Display on the LCD type front panel : ▲▼◀▶, RES(RESET), ENT(ENTER) Display on the touch panel screen ENT(ENTER), RES.(RESET) & 10 key	
Option	Front Panel (touch panel type) Part Name: Touch Panel Assembly Part Number: 910-073-0	
	Front panel (LCD type) Part Name: UEC-LCD Panel Assembly Part Number: 910-072-0	
	Part name: PC Cable Part Number: 910-219-0 Straight PC Cable for RS232C D-sub 9-pin female - D-sub 9-pin female 3 meter long	
	Torque Sensor Cable Part Name: Sensor Cable Assembly 3F5 Part Number: 910-263-0 Part Name: Sensor Cable Assembly 3F10 Part Number: 910-264-0	

## 4. Parts Names and Functions

### 4.1. Front Panel

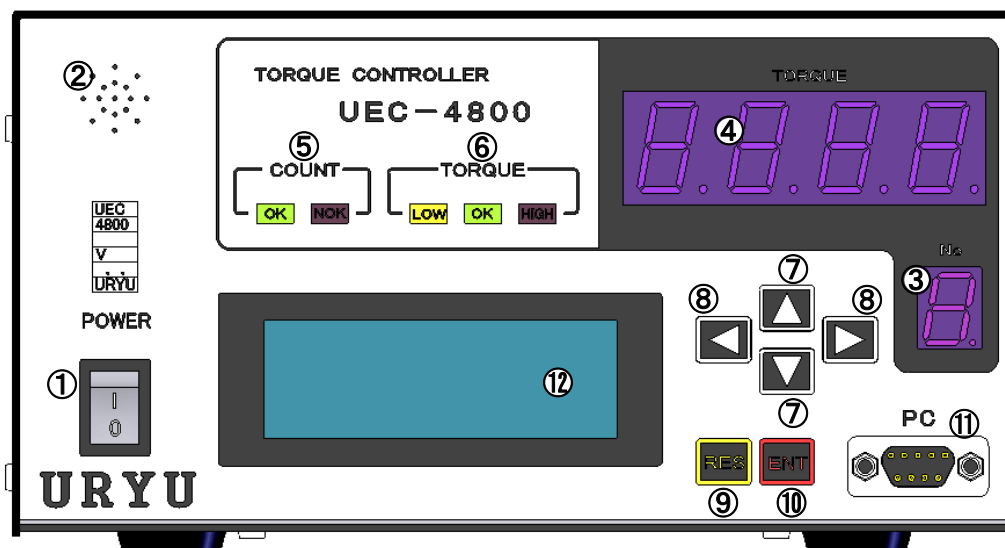

#### ① Power Switch

Switch for power supply. Turn off when you do not use UEC.

#### ② Buzzer

It sounds to announce for the confirmation of fastening, various errors, various NOK or key input.

Press **ENT** and the buzzer stops when an error is detected.

#### ③ 1-digit 7 segment display (No.)

It displays the work number now being selected.

#### ④ 4-digit 7 segment display (TORQUE)

It displays the measurement values and setting values.

#### ⑤ COUNT Lamp

OK : It lights when all the preset number of fasteners are tightened up.

NOK : It lights when the preset number of fasteners are not tightened up at the time of judgement.

#### ⑥ TORQUE Lamp

LOW : It lights when the measurement value is less than the preset lower limit value at the time of judgement.

OK : It lights when the measurement value is within the preset upper and lower limit values at the time of judgement.

HIGH : It lights when the measurement value is more than the preset upper limit value.

#### ⑦ ▲▼

These are used to move the cursor in the menu screen and increase/or decrease the setting values.

#### ⑧ ◀▶

These are used to select the unit of the value when the setting values are changed in the writing mode.

#### ⑨ RES Key Switch

It usually works to reset all. When NOK happens and it is pressed, it resets NOK.

#### ⑩ ENT Key Switch

It stops the buzzer, confirms the input of setting value, moves to the writing mode by pressing and holding it more than three seconds.

#### ⑪ PC Connector (D-sub 9 pin)

Connector cable between the PC for set up.

Use the straight cable.

#### ⑫ LCD Display (20 digit x 4 line)

Fastening time, pulse blow number, unfastened fastener number etc. and parameters are displayed.

## 4.2. Rear Panel

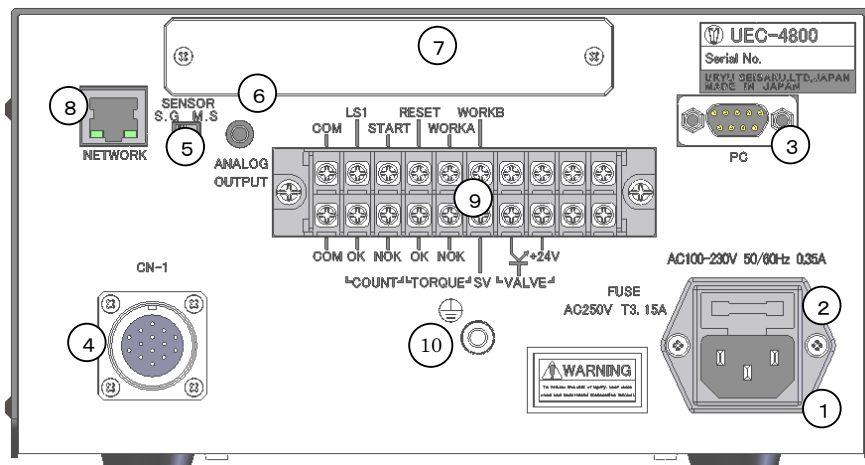

### ① Power cord box

Connect the power cord.

Make sure to ground the grounding wire of the power receptacle.

### ② Fuse holder

Protection fuse of UEC (3.15A)

### ③ PC connector (D-sub 9-pin female)

RS232C serial port for the data input and output.

Connect to the serial printer, PLC, PC, or the barcode reader.

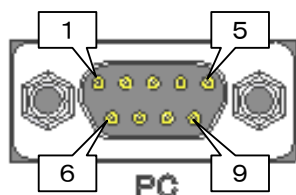

Pin Purpose	
Pin No.	Signal
1	FG (frame ground)
2	TXD (Transmit Data)
3	RXD (Receive Data)
4	DSR (Data Set Ready)
5	SG (Signal Ground)
6	DTR (Data Terminal Ready)
7	CTS (Clear to Send)
8	RTS (Request to Send)
9	Not Used

### ④ Connector for sensor cable

Connect sensor cable from a tool.

### ⑤ Sensor select switch

Select switch of either MS (URYU original magnetstrictive type sensor) or SG (strain gauge type sensor).

### ⑥ Analog output terminal

Terminal for the torque waveform output. Please refer to [13. Torque Waveform Measuring Procedure](#) and [14. ANALOG output terminal](#) for details.

### ⑦ Space for the optional board

Space for the optional board.

### ⑧ Network connector

Connector for Ethernet.

### ⑨ Input and Output terminals (free format)

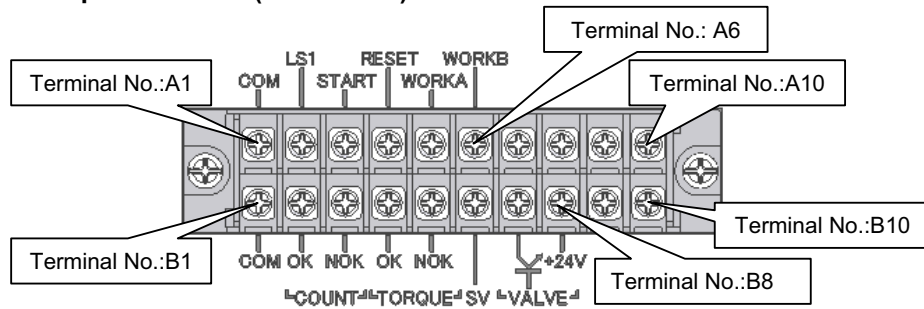

Terminal No.	Signal allocations	Terminal No.	Signal allocations
A1	COM: Common terminal for the input terminals (-)	B1	COM: Common terminal for output terminals
A2	LS 1: Input the line control signal	B2	COUNT ON: Output COUNT OK signal until timer comes up
A3	START: External start	B3	COUNT NOK: Output COUNT NOK signal until NOK is cleared
A4	RESET: Use to clear NOK	B4	TRQUE OK: Output TRQUE OK signal until timer comes up
A5	WORK A: Input for the work No. change	B5	TRQUE NOK: Output TRQUE NOK signal until NOK is cleared
A6	WORK B: Input for the work No. change	B6	SV: Output for change of slow speed or full speed. Output SV signal when the measured torque reaches the start torque.
A7	Not used	B7	VALVE: Valve Output (0V)
A8		B8	VALVE COM: +24
A9		B9	Not used
A10		B10	

Allocation of terminal board is free format. You can change the signal allocations of A2 – A6 and B2 – B6 by IN/OUT SETTING. It is not possible to allocate the signals to A7 – A10, B9 and B10.

- Contact input is necessary for the input to the input terminals A1 and A2 – A6.
- Output terminals of B1 and B2 – B6 is the no-voltage output. Wiring should be made at DC24V or less.
- Use Y-shape crimp contact or round-shape contact for the wiring to terminals.

### ⑩ Grounding terminal

Terminal for grounding. Make sure to use this terminal if the power cord does not have a ground wire.

## 5. Operation

### 5.1. Preparation

- 1) Connect the power cable to the power supply.
- 2) Connect Sensor Cable to CN-1 Connector of UEC, and connect sensor cable to a tool.
- 3) Switch on UEC-4800, and it makes the self-diagnosis check for 10 seconds. Carry out the visual check of the front LED lamps. 7 segment screen displays 「8.8.8.8」 「8」 and buzzer sounds.
- 4) 4-digit DPM displays 「\_8.8.8」 when there is nothing wrong with UEC-4800.

### 5.2. Key operation

- 1) Switch on UEC, and it makes the self-diagnosis check. After it is over, the screen changes to the measurement screen.
- 2) Press **ENT** in the measurement screen to go to the menu screen (DISPLAY SELECT).
- 3) Press **RES** in the measurement screen to clear the fastening error or make the ZERO/CALcheck.
- 4) Move the cursor : → up or down by **▲▼**
- 5) When the screen consists of two or more pages, the current page number and the total page numbers are shown in the upper right of the screen.
- 6) Press **▼** in the measurement screen to more to the next page, and press **▲** to move to the previous page.
- 7) Press **ENT** and hold it more than 3 seconds to enter the writing mode, and setting values get changeable.
- 8) While in the writing mode, press **▼** in the fourth line to move to the next page, and press **▲** in the first line to move back to the previous page.
- 9) Press **▲** or **◀** in the first line of the first screen to move to the previous screen.
- 10) Point the cursor [→] to the screen name you want to move, and press **ENT** to move to the screen you select.
- 11) Press **RES** in any screen to move back to the measurement screen.

### 5.3. Setting

There are two ways available, either by PC or by key switch on the front panel of UEC-4800 to change the setting values.

- (1) By PC (Please refer to the instruction manual of UEC-4800 setup software for details.)
  - 1) Connect the communication cable, straight cable, to [PC] connector in the front panel of UEC, and connect to PC through RS232C or Ethernet of NETWORK connector in the rear panel.
  - 2) Change the setting values in the setup software.
  - 3) Transmit the setting values set up in the setup software to UEC.
- (2) By Key Switch in the front panel
  - 1) Move to the screen you want to change the setting value.  
Press **ENT** and hold more than 3 seconds to enter the writing mode.
  - 2) Tool gets inoperable, and COUNT NOK lamp lights while in the writing mode.
  - 3) By using **▲▼**, point the cursor [→] to the setup item you want to change the setting value and press **ENT**
  - 4) By using **◀▶**, point the cursor to the unit of value to be changed.
  - 5) By using **▲**, increase the value. By using **▼**, decreases the value.
  - 6) After changing the setting values, press **ENT** to determine the values. Setting values are overwritten in the controller.
  - 7) Escape from the writing mode by pressing **RES** and move back to the measurement screen. The change of setting values is ended.

## 5.4. Self-diagnosis check

UEC-4800 has the self-diagnosis check function to check its component parts and detects the error. When UEC-4800 is turn on, the self-diagnosis check runs for approx. ten seconds from ROM, RAM, A/D, ZERO/CAL etc.

[Self-disgnosis check]

1) LED lamp and Buzzer

7 segment of the front panel displays [8.8.8.8.] [8.], and LCD display becomes as per the following. LED lamps light and buzzer sounds. Visually check every LED lamp lights and buzzer sounds in order.

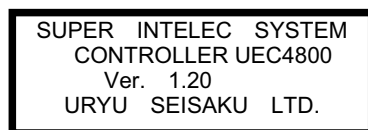

2) ROM IC performance check

Check if the memory IC (ROM), which memorizes the UEC control program, function normally.

3) RAM IC performance check

Check if the memory IC (RAM), which memorizes the UEC setting value and various kinds of measurement data, function normally.

4) A/D IC performance check

It checks if the analog-digital converter IC (A/D), which measures the torque data in analog value by CPU, operates properly or not.

5) Setting value storage data check (SUM check)

It checks if there is no error in the setup data memorized in RAM IC

## 6. IN/OUT CHECK

### 6.1. KEY CHECK (key input diagnosis)

It is possible to check if the key switch functions in order.

[ How to use ]

- 1) Press **ENT** in the measurement screen to move to the DISPLAY SELECT screen.
- 2) Point [ → ] to [CHECK SELECT] and press **ENT** to move to The IN/OUT CHECK screen.
- 3) Point [ → ] to [KEY CHECK] and press **ENT**.
- 4) Move to the KEY & LCD CHECK screen.

```

DISPLAY SELECT
SETTING
→CHECK SELECT
ZERO SET
    
```

```

IN/OUT CHECK SELECT
→KEY CHECK
INPUT CHECK
OUTPUT CHKCK
    
```

```

KEY&LCD CHECK
*****
*          *
*****
    
```

- 5) Select the key and press it, and the pressed key name is displayed in the LCD screen.

Key operation

Screen display



```

KEY&LCD CHECK
*****
* UP      *
*****
    
```



```

KEY&LCD CHECK
*****
* DOWN   *
*****
    
```



```

KEY&LCD CHECK
*****
* RIGHT  *
*****
    
```



```

KEY&LCD CHECK
*****
* LEFT   *
*****
    
```



```

KEY&LCD CHECK
*****
* RESET  *
*****
    
```



```

KEY&LCD CHECK
*****
* ENTER  *
*****
    
```

- 6) Press **ENT** twice in a row to finish KEY CHECK (key input diagnosis), and move back to the IN/OUT CHECK SELECT screen.

## 6.2. INPUT/OUTPUT CHECK (wiring diagnosis of the terminals and the tool)

By monitoring the input condition to the terminal block and making the compulsory signal output to either the terminal block or the tool, UEC checks the incoming wirings of the terminals of UEC, the tool and the sensor cable connected.

[ How to use ]

Either by the key switch or through the PC

### (1) Input wiring diagnosis by the key switch

- ① Press **ENT** in the MEASURING screen to enter the DISPLAY SELECT screen.
- ② Point [**→**] to [CHECK SELECT] and press **ENT** to move to the IN/OUT CHECK screen.

IN/OUT	CHECK
KEY	CHECK
→INPUT	CHECK
OUTPUT	CHKCK

- ③ Point [**→**] to [INPUT CHECK] and press **ENT** to move to the INPUT CHECK screen. UEC gets inoperable and TOTAL NOK lamp lights. 7 segment display shows [ - ] [ - - - - ].
- ④ When there is no signal being input externally, LCD displays becomes as follows;

INPUT	CHECK
INPUT1	INPUT4
INPUT2	INPUT5
INPUT3	

- ②When there are any input signals to the terminals, [ ■ ] is shown in the right of the terminal name which receives the input signal.

Example : When there are input signals coming to the terminal IN2 and IN5,

INPUT	CHECK
INPUT1 ■	INPUT4
INPUT2	INPUT5 ■
INPUT3	

- ⑥ Press **RES** to release after the key check.

(2) Output wiring diagnosis by the key switch

- ① Press **ENT** in the measurement screen to move to the DISPLAY SELECT screen.
- ② Point [ → ] to [CHECK SELECT] and press **ENT** to move to the IN/OUT CHECK screen.

```
IN/OUT CHECK
→KEY    CHECK
INPUT   CHECK
OUTPUT  CHKCK
```

- ③ Point [ → ] to [OUTPUT CHECK] and press **ENT** to move to the OUTPUT CHECK screen. [ - ] [ - - - - ] are displayed in the 7 segment display. UEC gets inoperable, and TOTAL NOK lamp lights.

```
OUTPUT CHECK
→OUTPUT1 OUTPUT4,
OUTPUT2  OUTPUT5
OUTPUT3
```

- ④ Point [ → ] by using **▲▼** to the terminal name you want to output and press **ENT**. Selected terminal is switched on and [ ■ ] is displayed right next to the terminal name. Point [ → ] to the terminal name now being switched on and press **ENT**, and the output of selected terminal gets off.

```
OUTPUT CHECK
→OUTPUT1 OUTPUT4,
OUTPUT2, OUTPUT5
OUTPUT3
```

- ⑤ Point [ → ] to OUTPUT 5 and press **▼** to move to the output wiring (to the too) diagnosis screen.

```
OUTPUT CHECK
→OK LED
NOK LED
VALVE
```

- ⑥ Press **RES** to release after the key check.

(4) Input/Output check by PC

- ① Connect the PC to UEC, and launch the setup software.
- ② Enter the inout/output check. UEC gets inoperable.
- ③ Check the wiring by monitoring the input condition, making the comparsory output.
- ④ Escape from the input/output check after finishing. Please refer to the instruction manual of the setup software for details.

While the input/output wiring diagnosis, the 7 segment display displays [-][— — — —] . UEC gets inoperable and TOTAL NOK lamp lights.

## 7. ZERO SET (zero point display)

UEC displays the values of the torque sensor's zero point and the cal number confirmed by the zero check and cal check.

UEC displays the values of the torque sensor's zero point and the cal number confirmed by the zero check and cal check.

Displayed values are of the absolute values. Minus (-) code is not displayed.

[ Key operation ]

- 1) Press **ENT** in the MEASUREMENT screen to move to the DISPLAY SELECT screen.

DISPLAY SELECT
SETTING
IN/OUT CHECK
→ZERO SET

- 2) Point the arrow [→] to [ZERO SET] and press **ENT** to move to the ZERO SET screen.

ZERO SET (WORK NO.1)	
ZERO	0
CAL	1000

- 4) Right of [ZERO] shows the zero point value, and [CAL] shows the CAL check value.  
Displayed values are of the absolute values. Minus (-) code is not displayed.

8. WORK No. change

UEC makes the work number change by short-circuiting the input signal terminals and the common terminal.

In accordance to the setting value of WORK SIG. SEL. of the MODE SETTING screen, the input signals to the terminals become different.

Input signal to the terminal		Work number to be selected
When 0 is set to WORK SIG. SEL.	When 1 is set to WORK SIG. SEL.	
No signal input	WORK 1	WORK 1
WORK A	WORK 2	WORK 2
WORK B	WORK 3	WORK 3
WORK A WORK B	WORK 4	WORK 4
WORK C	WORK 5	WORK 5
WORK A WORK C		WORK 6
WORK B WORK C		WORK 7
WORK A WORK B WORK C		WORK 8

**Note : When 1 is set to WORK SIG. SEL., you can use the work number from 1 up to 5.**

Following setups are necessary to activate the work number change.

(1) Determine the work number change method

When you want to change the work number by the combination of terminal WORK A, B and C, set 0 to WORK SIG. SEL. of the MODE SETTING screen. When you use the signal input of WORK 1, 2, 3, 4 and 5, set 1 to WORK SIG. SEL.

When 1 is set to WORK SIG. SEL., the work number can be changed maximum five only. When you use six or more work numbers, set 0 to WORK SIG. SEL.

(2) Allocate the input signal to the terminal block

Enter INPUT 1 screen of the IN/OUT SETTING screen.

① When 0 is set to WORK SIG. SEL.

When the work number to be used is two or less, assign WORK A to any of the input terminal from A1 to A5.

When the work number to be used is four or less, assign WORK A and WORK B to any of the input terminals from A1 to A5.

When the work number to be used is five or more, assign WORK A, WORK B and WORK C to any of the input terminals from A1 to A5.

② When 1 is set to WORK SIG. SEL.

Assign WORK 1, 2, 3, 4 and 5 to any of the input terminals A1, A2, A3, A4 and A5 in accordance to the work number to be used.

Ex.) When the work number to be used is three, assign [Input terminal A3 : WORK 1], [Input terminal A4 : WORK 2] and [Input terminal A5 : WORK 3]. You may assign with the input terminal A1, A2 and A3 to WORK 1, WORK 2 and WORK 3.

## 8.1. Torque polarity change

Unless torque polarity of UEC is changed over, UEC is unable to measure the torque of the counter-clockwise fasteners because the torque signal from the tool is input in the minus direction. You need to change over the UEC's torque polarity for counter-clockwise fasteners. Change over is made by DIP switch in the board inside of UEC.

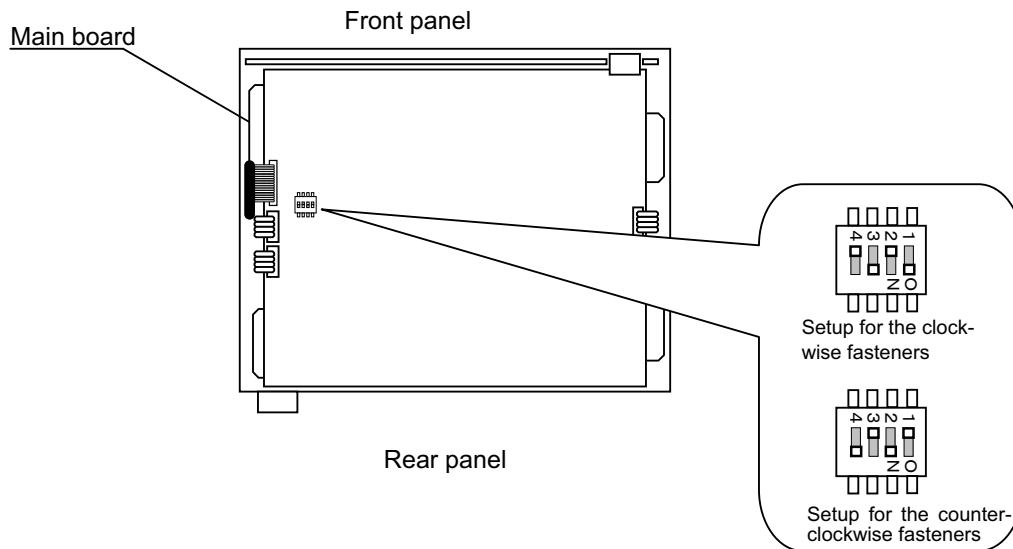

- Change the setting of DIP switch [SW3] in the main board in order to change the input polarity from torque sensor.
- For the clockwise fastener, set DIP switch 1 and 3 to ON position and 2 and 4 to OFF position.
- For the counter clockwise fastener, set DIP switch 1 and 3 to OFF position and 2 and 4 to the ON position.
- Even if the polarity change is made, the standard EC or MC wrenches for the clockwise fasteners do not shut off because of its structure. Add the external solenoid valve, or use counterclockwise exclusive tools.

## 9. Basic setting

The BASIC SETTING screen are divided into the following eight settings.

**BASIC** (Basic setting) : Basic settings for the tightening such as CUT (target torque level), LOW (lower limit level), HIGH (upper limit level).

**MODE** (Mode setting) : Settings for the way of line control and the usage selection of the various functions.

**TIMER** (Timer setting) : Settings for the timer of various timers.

**DATA OUT SET** (Data output setting) : Settings for the data output from the RS232C port on the rear panel of UEC-4800.

**TOOL CONTROL** (Tool control) : Settings for the maintenance period of tool by the total fastening numbers / total pulse numbers.

**IN/OUT PUT** (Terminal allocations setting) : Settings of the in/output signals allocated on the terminals.

**LAN** (LAN setting) : Settings of the Ethernet related items like IP address

**MEMORY DATA** (Memory data) : Settings for the memory data and screen display

**PROGRAM SEL** (Program No. Change) : Settings for the program number change

- (1) Press **ENT** in the MEASURING SCREEN to enter the DISPLAY SELECT screen.  
Point the arrow [→] to [SETTING] and press **ENT**.

```
DISPLAY SELECT
→SETTING
CHECK SELECT
ZERO SET
```

- (2) The screen goes to the SETTING WORK NO. screen. Select the work number you want to set up parameters.

```
SETTING WORK NO(1/3)
→WORK NO.1(#1)
WORK NO.2(#2)
WORK NO.3(#3)
```

```
SETTING WORK NO(2/3)
→WORK NO.4(#4)
WORK NO.5(#5)
WORK NO.6(#6)
```

```
SETTING WORK NO(3/3)
→WORK NO.7(#7)
WORK NO.8(#8)
```

- (3) The screen changes to the SETTING screen (setting menu screen). Select the mode name you want to set up parameters.

```
SETTING #1 (1/4)
→BASIC
MODE
TIMER
```

```
SETTING #1 (2/4)
→DATA OUT
TOOL CONTROL
IN/OUT PUT
```

```
SETTING #1 (3/4)
→LAN
```

```
SETTING #1 (4/4)
→MEMORY DATA
PROGRAM SEL
```

## 9.1. BASIC (Basic setting)

BASIC #1	(1/4)	
→TORQUE LOW		080.0
TORQUE HIGH		060.0
TORQUE CUT		019.6

BASIC #1	(2/4)	
→CAL		1000
TORQ.SENS. 1		700
TORQ.SENS. 2		0750

BASIC #1	(3/4)	
→START TORQUE		009.8
COUNT		99
PROOF. RATIO		01.00

BASIC #1	(4/4)	
→TOOL RATIO		01.00
PROOF. VALUE		1000

TORQUE LOW (Torque low limit value)

Default: 80.0 [Nm]

Setting range: 0.0 –999.7

Setting condition: Torque low limit value < Torque CUT value

**【Function】**

Value for the measured torque low limit judgment

TORQUE HIGH (Torque high limit value)

Default: 60.0 [Nm]

Setting range: 0.3 –999.9

Setting condition: Torque CUT value < Torque high limit value

**【Function】**

Value for the measured torque upper limit judgment

TORQUE CUT (Torque CUT value)

Default: 19.6 [Nm]

Setting range: 0.2 – 999.8

Setting condition: Torque low limit value } < Torque CUT value < Torque upper limit value  
 Start torque value }

**【Function】**

Fastening stop torque value under torque control

CAL (CAL value)

Default: 1000

Setting range: 100 - 9999

**【Function】**

- Set the CAL value stamped on the tool

TORQUE SENSOR 1 (Torque sensor resistance value [ $\Omega$ ])

Default: 700

**【Function】**

- Resistance value consisting of torque sensor circuit
- Choose from 480, 700 or 350, which agrees to the specifications of torque sensor connected.
- Set [700] for EC wrenches
- Do not enter any value for MC wrenches. [- - -] is displayed in the screen.

TORQUE SENSOR 2 (Torque sensor rated strain value)

Default: 750

Setting range: 100 - 4400

**【Function】**

- This is the total strain value of four pieces integrated strain gauges in the torque sensor when it is stressed by rated load.
- UEC calculates torque sensor output voltage by the applied stress from preset rated strain.
- The ratio is output voltage 0.5[mV/V] by applied strain 1,000.  
Example: Output voltage under strain 2,000 will be 1[mV/V].
- Set 750 for EC wrench use.
- Do not enter any figures for MC wrench use. Setting value is not displayed on the screen if the sensor select switch is set to MS.

START TORQUE (Start torque value)

Default: 9.8

Setting range: 0.1 - 999.7

Setting condition: Start torque value < Torque CUT value

**【Function】**

What Start torque value is;

- a. Start point of the judgment delay timer
- b. Start point of the initial error detection timer
- c. Start point of the cycle error detection timer
- d. Start point of the torque measurement start delay timer
- e. Start point of the fastening time measurement

Note: Enter 1/5 or greater value of the rated torque. Too low start torque value can make impossible both OK/NOK judgments and process to next cycle.

Example) When using ALPHA-60MC:

CAL : 200 x Proofreading ratio : 1.00 x Tool ratio : 1.00 = Proofreading Value : 200

200 x 1/50 = Start torque : more than 4.0 Nm

COUNT (Fastening number count / former name : COUNT)

Default: 99

Setting value: 1 - 99

**【Function】**

- Fastening number per work when using the fastener count down function.
- Not necessary to set up if you do not use the fastener number count control function.
- UEC provides COUNT OK/NOK judgments by the setting value of COUNT

#### PROOFREADING RATIO

Default: 1.00

Setting range: 0.01 - 9.99

##### 【Function】

This is the proofreading ratio which makes the break-away torque agree to the UEC displayed torque.

#### TOOL RATIO

Default: 1.00

Setting range: 0.01 – 9.99

##### 【Function】

Reduction ratio of the gear

Input the gear ratio when the tool that has the geared section in front of the torque sensor, like the geared type pulse wrench etc., is used.

#### PROOFREADING VALUE

Default: 1000

##### 【Function】

Proofreading ratio x Tool ratio x CAL value

This value enables the UEC-4800 to display the torque readings calculated by the torque signal voltage from torque sensor and by the percentage of sensor rating based on the torque sensor values.

## 9.2. MODE (Mode setting)

MODE #1 (1/11) →INITIAL TORQUE 0 CYCLE ERROR 0 FASTENING ERROR 1	MODE #1 (2/11) →UP/LOWER ERROR 1 INCOMPLETE JOB 0 TIME CONT. ST. 0	MODE #1 (3/11) →EXTERNAL START 0 BUZZER VOLUME 5 TIGHTENING MODE 3
MODE #1 (4/11) →ENGLISH・英字* 0 LINE CNT.SELEC 0 ALARM BUZZER 1	MODE #1 (5/11) →ST. TORQUE ERROR 0 CYCLE OVER 0 TIGHTING(TSS) 00000	MODE #1 (6/11) →PULSE LOW 0002 PULSE HIGH 0100 TORQ. CUT CONP. 0
MODE #1 (7/11) →ADDITION PULSE 1 FILTER CHANGE 1 UNIT CHANGE 0	MODE #1 (8/11) →WORK SIG. SEL 0 LAN OUT SEL. 0 ANG DETCT 0	MODE #1 (9/11) →ANG LOW LMT 000 ANG UPP LMT 100 SNUG TRQ 015.0
MODE #1 (10/11) →ANG CUT 999 ANG JUDG SEL 0 WAVE CNTNT SLT 2	MODE #1 (11/11) →PC COMM. SPEED 3 WAVE MEM FUNC 4	

INITIAL ERROR (Initial error detection) (former name: MODE 1)

Default : 0

Setting 0 : Not detect the initial error

Setting 1 : Detect the initial error

### 【Function】

Use to detect the double-fitting or cross thread.

UEC detects the initial error if the consumed time from torque start level to torque cut value is less than time of the initial error detection timer.

### 【When UEC detects the error】

- DPM display : [LO.E.] and [Torque measurement value] are displayed by turns.
- Front panel TORQUE lamp does not light
- Buzzer sounds.
- Terminal: TORQUE NOK is switched on.

### 【How to reset error】

- When 1 is set to FASTENING ERROR, next operation will reset the last error.
- Press **RES** in the screen, or switch on reset terminal.

CYCLE ERROR (Cycle error detection) (former name: MODE 2)

Default : 0

Setting : 0 Note detect cycle error

Setting : 1 Detect cycle error

### 【Function】

Use to regulate fastening time

UEC provides cycle error judgment if measured torque passes torque start level, but does not reach torque cut level when the cycle error detect timer comes up.

### 【When UEC detects the error】

DPM display : [CYL.E.] and [Torque measurement value] are displayed by turns.

Front panel TORQUE lamp does not light.

Buzzer sounds.

Terminal : TORWUE NOK terminal is switched on.

### 【How to reset the error】

- When 1 is set to FASTENING ERROR, next operation will reset the last error.
- Press **RES** in the screen, or switch on reset terminal.

## FASTENING ERROR

(After of post error detections LO.E/CYL.E/F.E) (former name: MODE 3)

Default : 1

Setting : 0 UEC gets non-operative status unless **RES** is pressed or reset terminal is switched on. Valve remains switched on.

Setting : 1 Next operation performs start-reset without pressing **RES** or switching on reset terminal, and UEC gets operative status.

When 0 is set to EXTERNAL START, the torque input (greater than start torque value) of next operation performs start-reset and UEC starts the torque measuring. When either 1, 2 or 3 is set to EXTERNAL START, the external start signal input of next operation performs start-reset and UEC starts the torque measuring.

## UP/LOWER LIMIT ERROR

(After of post upper or lower limit errors TORQUE/PULSE number/ANGLE) (former name : MODE 4)

Default : 1

Setting : 0 UEC gets non-operative status unless **RES** is pressed or reset terminal is switched on. Valve remains switched on.

Setting : 1 Next operation performs start-reset without pressing **RES** or switching on reset terminal, and UEC gets operative status.

When 0 is set to EXTERNAL START, torque input (greater than start torque value) performs start-reset and UEC starts torque measuring. When either 1, 2 or 3 is set to EXTERNAL START, external start signal input performs start-reset and UEC starts torque measuring.

## INCOMPLETE JOB (Incomplete job error detection) (former name: MODE 5)

Default : 0

Setting : 0 Not detect incomplete job error

Setting : 1 Detect incomplete job error

### 【Function】

UEC detects incomplete job error if the fastening is suspended before the torque reaches torque cut value after passing torque start value, like releasing finger from throttle lever due to mistake or socket dropping off.

Note: UEC provides the error when the fastening is suspended before the torque reaches torque cut level, even if the final torque is within low and high torque limits.

### 【When UEC provides the error】

DPM display : [F.E.] and [Torque measurement value] are displayed by turns.

Buzzer sounds.

Terminal: TORQUE NOK terminal is switched on.

### 【How to reset】

- When 1 is set to FASTENING ERROR, next operation resets the last error.
- Press **RES** in the screen, or switch on reset terminal.
- This function gets activated when either 3 or 5 is set to TIGHTENING MODE.

Note: UEC-4800 provides the error when the fastening is suspended before the torque reaches the torque cut level, even if the final torque is within low and high torque limits.

TIME CONT. ST. (Compulsory judgment) (former name: MODE 6)

Default : 0

Setting : 0 Not use

Setting : 1 Stops the tool and makes the compulsory judgment when cycle error detection timer comes up.

**【Function】**

- Use when you want to control fastening time without cycle error detection.
- UEC compulsory switches on solenoid valve to stop the tool and provides judgment if the tool fails to reach torque cut value beyond start torque value after cycle error detection timer comes up.
- When 2 is set to TIGHTENING MODE, fastening judgment delay timer starts functioning when the cycle error detection timer comes up.
- When either 1, 3 or 5 is set to TIGHTENING MODE, judgment delay timer starts functioning when the torque gets less than start value after the cycle error detection timer comes up.
- This function gets activated when 0 is set to CYCLE ERROR.

EXTERNAL START (External start specification) (former name : MODE 11) (Not used now)

Default : 0

Setting : 0 Not use the external start, but the measurement starts by the torque start.

Setting : 1 VALVE is switched on to start measurement, after ZERO/CAL check.

Setting : 2 VALVE is switched on to start measurement without doing ZERO/CAL check.

**【Function】**

- Determine the operation when start terminal is switched on
- When 1 or 2 is set, the operation starts functioning when external start (start terminal) is switched on.

BUZZER VOLUME

Default : 5

Setting range : 1 - 5

**【Function】**

- Determine the sound volume of buzzer
- The greater the number grows, the louder the buzzer sounds. 5 is the top volume, and 1 is the lowest volume.

ENGLISH (Selection of language)

Default: 0

Setting : 0 Japanese indication

Setting : 1 English indication

**【Function】**

- Determine the indication language for touch panel.
- When 0 is set, setup item name becomes [ENGLISH], and when 1 is set, setup item name becomes [日本語].

CONTROL METHOD (former name : MODE 9)

Default : 3

Setting : 1 Torque monitor

Provides the judgment to the measured torque, but does not control the torque.

Use to monitor the torque of the mechanical clutch type nutrunners etc.

Setting : 2 Torque control

Controls and provides the judgment to the measured torque

Use mainly for the pneumatic nutrunners

Setting : 3 Torque control for MC wrenches and EC wrenches

Use mainly for the MC wrenches and EC wrenches. Controls and provides the judgment to the measured torque.

Setting : 9 Torque monitor of T type wrenches

Use for T type wrench test on UFT (Uryu joint simulator)

LINE CNT. SELECT (Line control method select) (former name : MODE 14)

Default : 0

Setting : 0

UEC is always ready to count down the fasteners, and provides the judgment at the time of limit switch is switched on. UEC provides COUNT OK judgment if the preset number of fasteners is fastened up. When the LS (limit switch) 1 terminal is switched on, UEC is reset and ready for next operation. UEC provides COUNT NOK if any fasteners are left unfastened when LS1 is switched on. Tighten the unfastened fasteners, and UEC provides COUNT OK.

Note: When COUNT NOK is corrected to COUNT OK, the COUNT OK output becomes 1 pulse (1 sec).

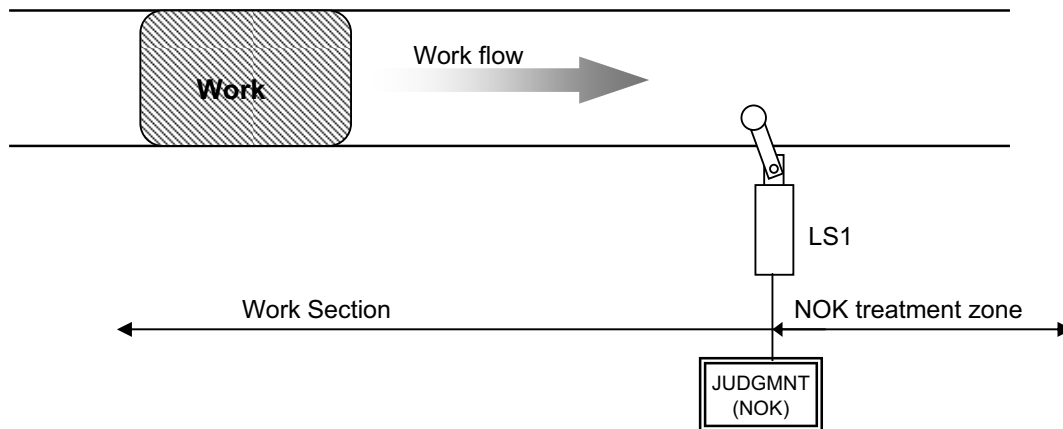

Setting : 1

Determine the work section. Switching on LS1 terminal becomes the start of the operation. Operation is over if the preset fasteners are fastened up until LS2 terminal is switched on. UEC provides COUNT NOK if any fasteners left unfastened when LS2 terminal is switched on. If the unfastened fasteners are fastened up in NOK treatment zone, UEC provides COUNT OK and the operation is over. Even if the unfastened fasteners are fastened up out of work section, UEC does not count down these fasteners.

Note: When COUNT NOK is corrected to COUNT OK, the COUNT OK output becomes 1 pulse (1 sec).

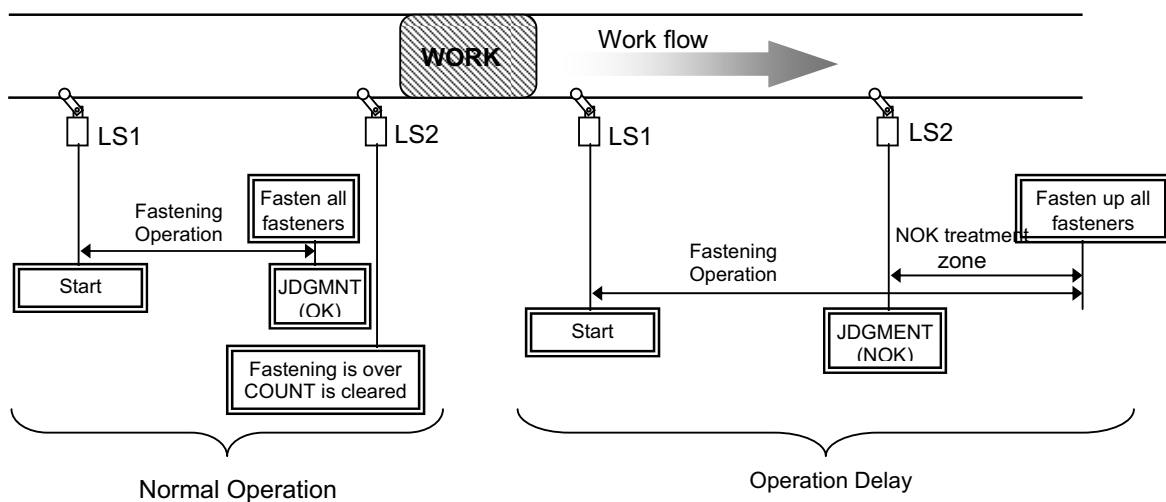

Setting : 2

Switch on the limit switch, and the operation starts and UEC provides the judgment when the timer comes up. Operation starts by switching on LS1 terminal, and the line control timer starts functioning. UEC provides COUNT NOK if the line control timer comes up before the preset number of fasteners is fastened up.

Note: When COUNT NOK is corrected to COUNT OK, the COUNT OK output becomes 1 pulse (1 sec).

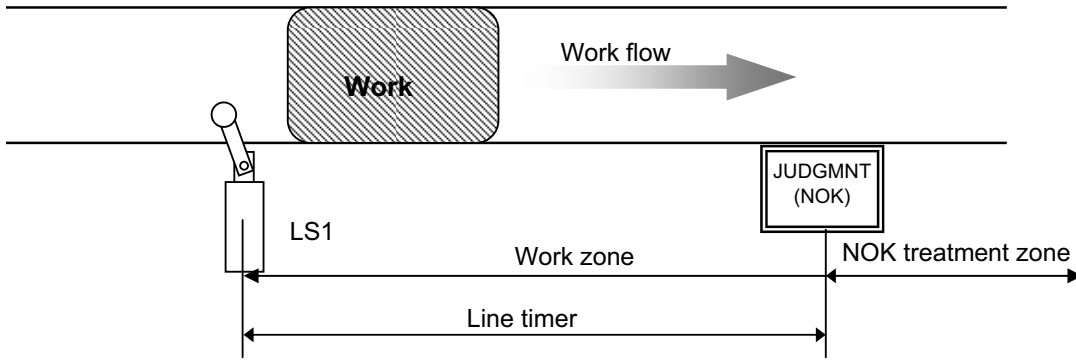

Setting: 3

Limit switch is not used, but the line control timer starts functioning by the first fastening operation. Line control timer gets started by either the judgment input of the first fastening or the signal input of QL wrench. UEC provides COUNT OK if the preset fasteners are fastened up, and gets ready for next operation when COUNT OK output signal is switched off. COUNT OK signal output duration time is set up by COUNT OK of TIMER SETTING. UEC provides COUNT NOK if the line control timer comes up before the preset fasteners are fastened up.

Note: When 3 is set to LINE CNT. SELECT, you cannot set up the COUNT OK signal output duration time (COUNT OK : 0).

When COUNT NOK is corrected to COUNT OK, the COUNT OK output becomes 1 pulse (2 sec).

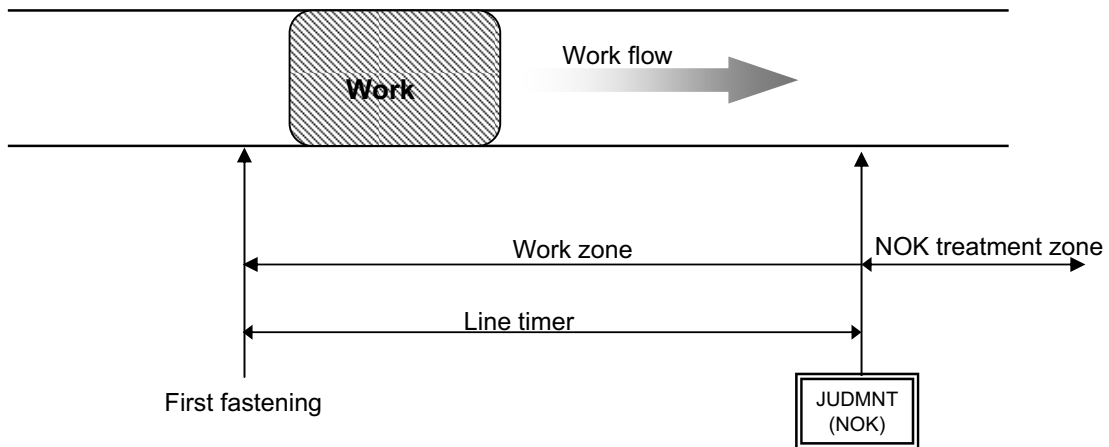

Setting 4

By any of WORK 1 – 5 signal input, UEC gets ready to start fastening of the selected work number. Set 1 to WORK SIG. SEL.

When the preset fasteners are fastened up, COUNT OK signal terminal is switched on corresponding to the selected work number. [WORK 2 COUNT OK] output terminal is switched on when UEC provides COUNT OK of work No. 2.

Set up the COUNT OK signal output duration time per work number in COUNT OK of TIMER SETTING.

UEC provides COUNT OK signal output for 1 second, when COUNT NOK is corrected in NOK treatment zone by fastening the unfastened fasteners or switching on pass terminal.

Make sure to switch off WORK SELECT signal input when COUNT OK signal output is switched on. Switch off WORK SELECT signal input, and COUNT OK signal output is switched off.

UEC provides COUNT NOK when any input signal of WORK 1 – 5 is switched off before the preset fasteners are fastened up.

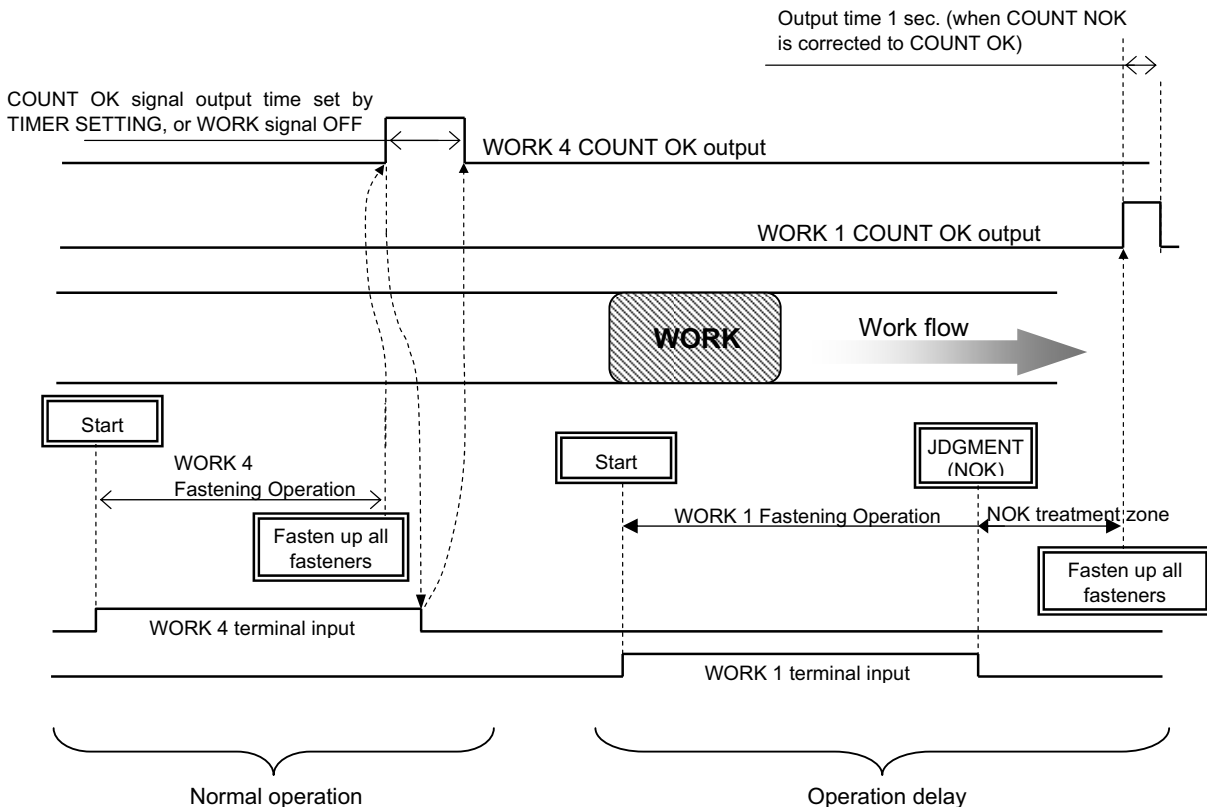

ALARM BUZZER (Fastening confirmation buzzer output) (former name : MODE 15)

Default : 0

Setting : 0 Buzzer does not sound.

Setting : 1 Buzzer sounds for every OK fastener.

**【Function】**

- Buzzer gives 1 pulse sound for every OK fastener, and 2 pulses sound for fastener COUNT UP.

ST. TORQUE ERROR (Start torque error detection) (former name : MODE 16)

Default : 0

Setting : 0 Not detect the start torque error

Setting : 1 Detect the start torque error

Note: Set to 0.

Not used now

CYCLE OVER (Cycle over time error detection) (former name : MODE 17)

Default : 0

Setting : 0 Not detect the cycle over time error

Setting : 1 Detect the cycle over time error

Note: Set to 0.

Not used now

TIGHTENING (Fastening time display (TSS))

**【Function】**

- UEC display the time consumed from the external start signal input to the torque start level.

Note : This is not the setting.

Not used now

PULSE LOW (Pulse blow number low limit value [pulse]) (former name : MODE 34)

Default : 2

Setting range : 0 – 9998 (pulse number low limit value, maximum 9998, < pulse number upper limit value, maximum 9999)

**【Function】**

- Lower limit value of the pulse blow number that UEC provides pulse number LOW NOK judgment. UEC provides pulse number LOW NOK when the total pulse number generated from the start torque until the cut torque is less than the pulse number low limit value.

**【When UEC detects the error】**

- DPM display : [PLS.L.] and [Torque measurement value] are displayed by turns.
- Buzzer sounds.
- Terminal : TORQUE NOK is switched on.

**【How to reset】**

- When 1 is set to UP/LOWER LIMIT ERROR, next operation performs the start-reset.
- Press **RES** in the screen, or switch on reset terminal.

Note: This function gets activated when 3 is set to TIGHTENING MODE.

#### PULSE HIGH (Pulse number upper limit value [pulse]) (former name : MODE 35)

Default : 100

Setting range : 1 – 9999 (Pulse number low limit value, maximum 9998 < pulse number upper limit value, maximum 9999)

##### 【Function】

- Pulse numbers that UEC provides pulse number HIGH NOK judgment. UEC counts total pulse numbers generated from torque start level to cut level, and provides pulse number HIGH NOK judgment with solenoid valve closed to stop the tool and the error display when the total pulse number is more than the pulse number upper limit value.

##### 【When UEC detects the error】

- DPM display : [PLS.H.] and [Torque measurement value] are displayed by turns.
- Buzzer sounds.
- Terminal : TORWUE NOK is switched on.

##### 【How to reset】

- When 1 is entered to UP/LOWER LIMIT ERROR, next operation performs the start-reset.
- Press **RES** in the screen, or switch on reset terminal.

Note: This function gets activated if 3 is entered to TIGHTENING MODE.

#### TORQUE CUT CONP. (Torque measurement during compensation pulsing post CUT level)

Default : 0

Setting : 0 UEC measures, controls and provides final judgment with the highest peak torque display of compensation pulsing under the pulse number counting.

Setting : 1 UEC gives judgment due to torque measurement of pulsing until torque cut level, but does not measure torque of pulsing post torque cut level.

#### ADDITION PULSE (Compensation pulse numbers post CUT level) (former name : MODE 27)

Default : 1

Setting : 1 – 5

##### 【Function】

- UEC switches on solenoid valve to stop the tool when preset additional pulse numbers have been counted after reaching the torque CUT level.
- This function gets activated if either 3 or 5 is entered to TIGHTENING MODE.
- Set 1 for the tools like angle nutrunner etc. whose torque is expressed in a continuous wave.

Note: Set 1 if you do not use this function.

#### FILTER CHANGE

Default : 1

Note: Not changeable

#### TORQUE UNIT CHANGE

Default : 0

Setting : 0 Nm

Setting : 1 kgf/cm

Setting : 2 kgf/m

Setting : 3 ft/lbf

Setting : 4 dNm

Note: Not usable with the domestic type UEC-4800 series

WORK SIG. SEL. (Work signal combination) (former name : MODE 29)

Default : 0

Setting : 0 UEC changes up to 8 work numbers by using the terminals of WORK A, WORK B and WORK C.

Setting : 1 UEC changes up to 5 work numbers by using the input terminals of WORK 1-1 to WORK 1-5.

Refer to 8. Work Number Change for details.

- Setting 1 is used when LINE CNT. SELECT is set with 4.

ANGLE DETECT (Spare for angle detect)

Default: 0

Setting: 0, 1, 2, 3 or 4

Not used now

ANG LOW LMT (Angle low limit value [degree])

Default:

Setting range : 0 - 999

**【Function】**

- This is angle low limit judgment value
- UEC provides angle LOW NOK when measured angle is smaller than preset angle low limit at the time of judgment.
- When 0 is set, UEC does not provide the angle low judgment.

**【When UEC detects the error】**

DPM display: [ANGLE LOW]

Buzzer sounds.

Terminal : TORQUE NOK terminal is kept switched on until the error is reset.

**【How to reset】**

When 1 is set to UP/LOWER LIMIT ERROR, next operation performs the start-reset.

Press **RES** in the screen, or switch on reset terminal.

Not used now

ANG UPP LMT (Angle upper limit value [degree])

Default : 0

Setting range : 0 - 999

**【Function】**

- This is angle high limit judgment value.
- If the setting value is 1 – 999, UEC provides angle HIGH NOK if the measured angle is greater than angle upper limit value.
- If 0 is set, UEC does not provide the angle upper judgment.

**【When UEC detects the error】**

UEC closes the solenoid valve to stop the tool.

DPM display : [ANGLE HIGH]

Buzzer sounds.

Terminal : TORQUE NOK is kept switched on until the error is reset.

**【How to reset】**

When 1 is set to UP/LOWER LIMIT ERROR, next operation performs the start-reset.

Press **RES** in the screen, or switch on reset terminal.

Not used now

#### SNUG TRQ (Snug torque)

Default :

Setting range : 0.0 – 999.8

Setting condition : Start torque value < snug torque value < CUT torque value

#### 【Function】

- This is the torque from when UEC started measuring the angle.

Not used now

#### ANG CUT (Angle CUT value)

Default : 999

Setting range : 0 - 999

Setting condition : Angle lower limit value < angle CUT value < angle low limit value

#### 【Function】

This is the fastening stop angle judgment value when the angle control is effective.

Use this function when 6 is set to TIGHTENING MODE.

Not used now

#### ANG JUDG SEL (Angle judgment select)

Default : 0

Setting : 0 Not provide the angle judgment.

Setting : 1 Provides the angle judgment and detects the error.

Setting : 2 Provides the angle judgment and detects the WRN instead of the error.

#### 【Function】

- This is to select if UEC provides the angle high and low judgment and the snug angle high and low limit error judgment (or high and low limit warning).
- When 1 is set, UEC provides fastening NOK when detecting the error.
- When 2 is set, UEC does not provide fastening OK/NOK judgment, but provides WARNING (WRN) and counts down the fasteners.

Not used now

#### WAVE CNTNT SLT (Waveform data contents select)

Default : 0

Setting : 0 100μsec

Setting : 1 1 msec

Setting : 2 2 msec

Setting : 3 5 msec

#### 【Function】

- When 0 is set, UEC displays the measured torque waveform without peak holding on the screen, and output the data to outside (100μsec sampling).
- When either 1, 2 or 3 is set, the measured torque waveform is converted to the peak hold waveform per 1msec/2msec/5msec on the screen and UEC outputs the data to outside.
- When 0 is set to this mode, and when the waveform data is sent to the waveform data screen of the UEC-4800 setup software, the buffer of the waveform becomes 5. When either 1, 2 or 3 is set, the buffer becomes 50.

PC COMM. SPEED (PC communication speed / former name : MODE 46)

Default : 3

Setting : 1 9600 bps

Setting : 2 19200 bps

Setting : 3 38400 bps

**【Function】**

Note: This is to determine the communication speed between UEC and PC. This is not the communication speed of the data output port in rear of UEC.

Note: Switch off UEC after you change the setting value of the PC port communication speed. Setting value will not be overwritten unless UEC is once switched off.

WAVE MEM FUNC (Waveform memory function select)

Default : 4

Setting : 1 Not memorize

Setting : 2 Memorize and notice both with the display message and buzzer sound

Setting : 3 Memorize and notice with the display message, but not sound the buzzer

Setting : 4 Memorize the wave data, but not notice with neither the display message nor the buzzer sound.

**【Function】**

This is to determine if or not UEC memorize the waveform data, and if or not provide the notice by either the display message [ *b u F. E.* ] or buzzer sound or both when the memory becomes full.

### 9.3. TIMER (TIMER setting)

TIMER #1 (1/6) →JUDGEMENT DELAY 0300 INITIAL ERROR 0500 CYCLE ERROR 5000	TIMER #1 (2/6) →FASTENING OK 9999 COUNT OK 9999 TOR.MEAS.DELAY 0020	TIMER #1 (3/6) →ST. TORQUE ERROR 0500 CYCLE OVER ERROR 9999 VALVE RETURN 0300
TIMER #1 (4/6) →REVERSE ROTATE 0300 PIN ADJUSTMENT 0000 LINE CONTROL 0100	TIMER #1 (5/6) →YEAR 0006 MONTH 0001 DAYS 0010	TIMER #1 (6/6) →HOURS 0013 MINUTS 0015 SECONDS 0030

JUDGMENT DELAY (Judgment delay timer / former name : TIMER 1)

Default : 300 [msec]

Setting range : 100 – 9999 [msec]

**【Function】**

- This is to set time interval how long UEC delays judgment output after one fastening has been completed.
- Use this timer as the torque measurement end point when UEC is in control operation.
- Take torque spike after CUT into your consideration to determine length of this timer.

**【Guideline of set value】**

- 300 [msec] for oil pulse wrenches
- 500 [msec] for continuous tool like angle nutrunners

INITIAL ERROR (Initial error detection timer / former name : TIMER 2)

Default : 500 [msec]

Setting range : 1 – 9999 [msec]

**【Function】**

- Use this timer when 1 is INITIAL ERROR.
- This is to determine the minimum time from start torque to cut torque. UEC provides NOK if the torque reaches cut torque earlier than this timer comes up.
- This timer starts functioning when measured torque reaches start torque level.

CYCLE ERROR (Cycle error detection timer / former name : TIMER 3)

Default : 5000

Setting range : 1 – 9999 [msec]

**【Function】**

- This is to determine the maximum time from start torque to cut torque. UEC provides NOK if the torque does not reach cut torque even after this timer comes up.
- This timer starts functioning when measured torque reaches start torque level.
- It is necessary to set this timer when 1 is set to CYCLE ERROR (former name : MODE 2) or when 1 is set to TIME CONT. ST. (former name : MODE 6).

FASTENING OK (Fastening OK signal output timer / former name : TIMER 4)

Default : 9999

Setting range : 0 – 9999 [msec]

**【Function】**

- This is to determine the fastening OK signal output duration time from output terminal TORQUE OK. Not necessary to set up this timer usually.
- Set up this timer only when duration of output signal affects external PLC or circuit.
- Set 0, and UEC maintains signal output until next cycle starts.

COUNT OK (COUNT OK signal output timer / former name : TIMER 5)

Default : 9999

Setting range : 0 – 9999[msec]

**【Function】**

- Determine COUNT OK signal output duration time from output terminal COUNT OK.
- Set 0, and UEC maintains signal output until next cycle.

TORQ. MEAS. DELAY (Torque measurement start delay timer / former name : TIMER 6)

Default : 20

Setting range : 0 – 9999 [msec]

**【Function】**

- UEC start torque measurement when this timer comes up. (UEC does not measure the torque until this timer comes up.)
- Timer starts functioning when the torque reaches torque start level. (When the external start is used, the timer starts functioning when start terminal is switched on.)
- Use this timer when the torque spike can happen at the bolt or nut seating point.

ST. TORQUE ERROR (Start torque error detection timer / former name : TIMER 7)

Default : 500

Setting range : 1 – 9999 [msec]

**【Function】**

- This is to determine the minimum time from when UEC switches on START terminal until the torque reaches start torque.
- This timer starts functioning when START terminal is switched on.
- Set this timer when 1 is set to ST. TORQUE ERROR.

Not used now

CYCLE OVER ERROR (Cycle over error detection timer / former name : TIMER 8)

Default : 9999

Setting range : 1 – 9999 [msec]

**【Function】**

- This timer starts functioning when START terminal is switched on.
- Set this timer when 1 is set to CYCLE OVER (former name : MODE 17).

Not used now

#### VALVE RETURN (Valve return timer / former name : TIMER 20)

Default : 300

Setting range : 1 – 9999 [msec]

##### 【Function】

- This timer starts functioning when the judgment delay timer comes up, and UEC switch off the valve (valve on) when this timer comes up.

##### 【Guideline of setting】

- 300 [msec] for the valve integrated type tools like MC wrenches
- 500 [msec] for the valve external type tools like ULMC series
- When the long cable is used between a tool and a valve, set up the larger value to this timer.
- When the external valve is used, and when after UEC switch on VALVE terminal to stop a tool and it switch off VALVE terminal before a tool's lever is released, set the bigger value to this timer. If a tool does not operate by next operation, adjust to the smaller value.

#### REVERSE ROTATION (Reverse rotation complete delay timer / former name : TIMER 21)

Default : 300

Setting range : 0 – 9999 [msec]

##### 【Function】

- This timer is to control tool's reserve operation complete.
- Use this timer when 9 is set to TIGHTENING MODE.

Not used now

#### PIN ADJUSTMENT (Pin hole alignment timer / former name : TIMER 40)

Default : 0

Setting range : 0 – 9999 [msec]

##### 【Function】

- Use this timer to align bolt pin and the hole in a line.
- This timer starts functioning when UEC provides the torque judgment. UEC suspends torque measurement until this timer comes up. Turn the fastener to align bolt pin and a hole in a line while UEC suspends torque measurement.

Note: Set 0 if you do not do pin hole alignment.

#### LINE CONTROL (Line control timer / former name : TIMER 50)

Default : 100

Setting range : 1 – 9999 [sec]

##### 【Function】

- Use this timer when either 2 or 3 is set to LINE CNT. SELECT (former name : MODE 14). This timer is to make line control by time.

#### YEAR

Default : 0

Setting range : 0 – 99 [Year]

##### 【Function】

- This is to set the year of calendar timer of UEC.
- Enter 0, and the year of calendar timer is set to [Year 2000]. Enter 6, and the year of calendar time is set to [Year2006].

## MONTH

Default : 0

Setting range : 1 – 12 [Month]

### 【Function】

- This is to set the month of calendar timer of UEC.

## DAY

Default : 0

Setting range : 1 – 31 [Day]

### 【Function】

- This is to set the day of calendar timer of UEC.

## HOUR

Default : 0

Setting range : 0 – 24 [Hour]

### 【Function】

- This is to set the time of hour of calendar timer of UEC.

## MINUTES [Minutes]

Default : 0

Setting range : 0 – 59 [Minutes]

### 【Function】

- This is to set the time of minutes of calendar timer of UEC.

## SECONDS

Default : 0

Setting range : 0 – 59 [Seconds]

### 【Function】

- This is to set the time of minutes of calendar timer of UEC.

## 9.4. Data output setting

Determine the contents of the output data and memory data sent through the serial port.

DATA OUT (1/6) →UEC No. 01 OUT.MOVEMENT 0 OUTPUT OF FORM 0	DATA OUT (2/6) →COMM.SPEED 1 BIT 0 STOP 1	DATA OUT (3/6) →PARITY 0 TORQ.VAL.TRANS 1 PULSE NUMB. 1
DATA OUT (4/6) →FASTENED TIME 1 DECISION 1 WAVE DATA OUT 0	DATA OUT (5/6) →ANG. DATA TRANSM 0 WAVE DATA FORM 0 ID DATA OUT 0	DATA OUT (6/6) →ID DATA FORM 00

UEC NO. (former name : MODE 98)

Default : 1

Setting : 1 – 25

**【Function】**

Give every UEC its own number when plural UECs are in use connected to PC by RS232C.

OUT. MOVEMENT (former name : MODE 58)

Default : 0

Setting : 0 Output all data through RS232C

Setting : 1 Output only the following errors through RS232C

- Torque/Pulse blow number [PLS.L.PLS.H.]/High & Low angle errors
- Fastening errors [LO.E./CYL.E./F.E.]

Setting : 2 Not output through RS232C

OUTPUT OF FORM (Data system select for RS232C output / former name : MODE 59)

Default : 0

Setting : 0 # - CR

Setting : 1 # - LF

Setting : 2 ENQ, No ACK/NAK – ET

Setting : 4 UEC-4500 type (correspond with the UEC software version 1.22 and later one)

Setting : 5 UEC-4100 type (correspond with the UEC software version 1.22 and later one)

**【Function】**

Determine system of the contents of output data sent through RS232C port in rear of UEC.

COMM. SPEED

(Communication speed select for RS232C output baud rate / former name : MODE 60)

Default : 1

Setting : 0 4800 bps

Setting : 1 9600 bps

Setting : 2 19200 bps

**【Function】**

This is to determine the baud rate of the output data sent through data output RS232C port.

Note: This is not the communication speed between PC and UEC.

BIT (Bit length select of the RS232C output / former name : MODE 61)

Default : 1

Setting : 0 7 bit

Setting : 1 8 bit

**【Function】**

This is to determine the bit length of output data sent through data output RS232C port.

STOP (Stop bit select of the RS232C output / former name : MODE 62)

Default : 0

Setting : 0 1 bit

Setting : 1 2 bit

**【Function】**

This is to determine the stop bit of output data sent through data output RS232C port.

PARITY (Parity bit select of the RS232C output / former name : MODE 63)

Default : 0

Setting : 0 No parity

Setting : 1 Even number parity

Setting : 2 Odd number parity

**【Function】**

This is to determine the parity check of output data sent through data output RS232C port.

TORQ. VAL. TRANS (Torque value transmit select / former name : MODE 64)

Default : 1

Setting : 0 Not output

Setting : 1 Output (5 byte including the decimal point)

**【Function】**

This is to determine whether include or not the torque value in the output data transmitted through data output RS232C port.

PULSE NUMB. (Pulse blow number output select / former name : MODE 67)

Default : 1

Setting : 0 Not output

Setting : 1 Output

**【Function】**

This is to determine whether include or not the pulse blow number in the output data transmitted through data output RS232C port.

FASTENED TIME (Fastening time output select / former name : MODE 68)

Default : 1

Setting : 0 Not output

Setting : 1 Output

**【Function】**

This is to determine whether include or not the fastening time from start torque till cut torque in output data transmitted through data output RS232C port.

DECISION (Fastening judgment output select / former name : MODE 69)

Default : 1

Setting : 0 Not output

Setting : 1 Output

**【Function】**

This is to determine whether include or not the judgment in output data sent through data output RS232C port.

Contents	ASCII code	HEX code
TORQUE OK	@	40H
START LEVEL ERROR	C	43H
CYCLE ERROR	D	44H
INITIAL ERROR	E	45H
CYCLE OVER ERROR	F	46H
INCOMPLETE JOB ERROR	G	47H
TORQUE LOW NOKK	H	48H
TORQUE HIGH NOK	I	49H
PULSE LOW NOK	L	4CH
PULSE HIGH NOK	M	4DH
PASS	P	50H
QL	Q	51H

WAVE DATA CNTNT SLCT (Wave data content output select)

Default : 1

Setting : 0 Not output

Setting : 1 Output

Setting : 2 Output when NOK

**【Function】**

This is to determine whether output or not the waveform data to UEC-4800 setup software. It does not effect to the RS232C output of the rear panel.

ANG DATA TRANSM SLCT (Fastening angle output select / former name : MODE 65)

Default : 1

Setting : 0 Not output

Setting : 1 Output

**【Function】**

This is to determine whether include or not the angle in output data sent through data output RS232C port.

WAVE DATA FORM (Wave form data output select)

Default : 0

Setting : 0 Send by Binary format (2 byte per data)

Setting : 1 Send by ASCII format (4 byte per data)

**【Function】**

This is to determine the file format to send waveform data to the UEC-4800 setup software. Set 0 (Binary) at present.

ID DATA SLCT (ID data output select)

Default : 0

Setting : 0 Not output

Setting : 1 Output

**【Function】**

This is to determine whether include or not ID number in output data sent through data output RS232C port.

Set 1 when connecting to Global Pokayoke.

ID DATA NUMB. (ID data digit number)

Default : 0

Setting range : 1 - 48

**【Function】**

This is to determine the digit number of VIN NO.

Not used digit is filled with [0].

## 9.5. Tool Control

UEC can memorize the total fastening number and pulse number since a tool is brought into use. It enables UEC to provide a notice of simple maintenance such as oil change by [WARNING COUNT/PULSE] and parts replacement/overhaul by [REPAIR COUNT/PULSE].

TOOL CONTROL (1/3)	TOOL CONTROL (2/3)	TOOL CONTROL (3/3)
→TIGHTING COUNT 00000	→WARNING COUNT 00	→REPAIR PULSE 000
TIGHTING PULSE 00000	WARNING PULSE 000	
TOOL DAT. CLEAR 0	REPAIR COUNT 00	

TIGHTENING COUNT (Total tightening count number [1 unit : 10,000 fasteners])

Default : 0

Setting range : 0 – 99999 [1 unit : 10,000 fasteners]

- This is total fastening number of the tool now in use since the start of use.
- Fastening numbers of NOK fasteners are included.

TIGHTENING PULSE (Total fastening pulse blow number [ 1 unit : 10,000 pulses])

Default : 0

Display range : 0 – 99999 [ 1 unit : 10,000 pulses]

- This is the total pulse blow number of the tool now in use since the start of use.
- Pulse blow numbers of NOK fasteners are included.

TOOL DAT. CLEAR (Tool data clear)

Default : Y

Set to 1 to clear the total fastening number and pulse number.

Note : This is not setting.

WARNING COUNT (Warning count number [1 unit : 10,000 fasteners])

Default : 30

Setting range : 0 – 9998 [ 1 unit : 10,000 fasteners]

- UEC displays a warning message when the total fastening number reaches preset cycles.
- Set the fastening number that you are going to repair a tool next time.

**【Display status when fastening number reaches warning cycle】**

- Buzzer sounds. Press **ENT** to stop.
- 7 segment displays [kcH.E.]

Note: Set [0] when not use.

WARNING PULSE (Warning pulse blow number [1 unit : 10,000 pulses])

Default : 30

Setting range : 0 – 9998 [1 unit : 10,000 pulses]

- UEC displays a warning message when the total pulse blow number reaches preset pulses.
- Set the number of pulse blow that you are going to repair like oil change a tool next time.

**[Display status when number of pulse blow reaches warning pulse]**

- Buzzer sounds. Press **ENT** to stop.
- 7 segment displays [kcP.E.]

Note: Set [0] when not use.

REPAIR COUNT (Repair count number [1 unit : 10,000 fasteners])

Default : 50

Setting range : 0 – 9999 [1 unit : 10,000 fasteners]

- UEC will let you know by a message when the total fastening number reaches preset cycle.

**[Display status when the total fastening number reaches repair cycles]**

- Buzzer sounds.
- CAUTION terminal is switched on.
- 7 segment displays [rPH.E.]

Note : Set 0 when not use.

REPAIR PULSE (Repair pulse blow number [ 1 unit : 10,000 pulses])

Default : 50

Setting range : 0 – 9999 [ 1 unit : 10,000 pulses]

- UEC lets you know by a message when the total pulse blow number reaches the preset pulses.

**[Output status when the total pulse blow number reaches the preset pulses]**

- Buzzer sounds.
- CAUTION terminal is switched on.
- 7 segment displays [rPP.E.]

Note : Set 0 when not use.

## 9.6. IN/OUT PUT (Setting of signal allocations of input/output terminal board)

Signal allocations of input and output terminal board is free format. You can change signal allocations as required by setting.

IN/OUT PUT (1/4)		
→IN TERMINAL 1	01	
IN TERMINAL 2	02	
IN TERMINAL 3	03	

IN/OUT PUT (2/4)		
→IN TERMINAL 4	07	
IN TERMINAL 5	08	

IN/OUT PUT (3/4)		
→OUT TERMINAL 1	01	
OUT TERMINAL 2	02	
OUT TERMINAL 3	03	

IN/OUT PUT (4/4)		
→OUT TERMINAL 4	04	
OUT TERMINAL 5	05	

### Setting of input terminals

Set the signal allocations of input terminals by IN TERMINAL 1 to IN TERMINAL 5.

Default and name of terminal

Setup item	Default (function)	Name of terminal
IN TERMINAL 1	1 (LS1)	LS1
IN TERMINAL 2	2 (START)	START
IN TERMINAL 3	3 (RESET)	RESET
IN TERMINAL 4	7 (WORK A)	WORK A
IN TERMINAL 5	8 (WORK B)	WORK B

### Setup item

Setting	Name of Signal	Function
1	LS 1	When 0 is set to LINE CNT. SELECT, provide judgment signal. When either 1 or 2 is set, provide start fastening process signal.
2	START	External start
3	RESET	Reset the number of unfastened fasteners. (Reset the error, but hold the number of unfastened fasteners when the error happens.)
4	LS 2	Judgment (use when 1 is set to LINE CNT. SELECT)
5	PASS	Compulsory completion Provide COUNT OK compulsory even if there are unfastened fasteners.
6	QL	Signal for QL wrench. Count down the fasteners.
7	WORK A	Signal for WORK select.
8	WORK B	Select WORK No. 1 – 8 by the signal combination of WORK A – C.
9	WORK C	Use when 0 is set to WORK SIG. SEL.
10	WORK 1	Signal for WORK select Select WORK No. 1 – 5 by the input signal combination of WORK 1 – 5. Use when 1 is set to WORK SIG. SEL.
11	WORK 2	
12	WORK 3	
13	WORK 4	
14	WORK 5	
15	CUT	Stop a tool externally

Note: It is not possible to assign same signal to two or more terminals.

## Setting of output terminals

Set up the signal allocations of output terminals by OUT TERMINAL 1 – OUT TERMINAL 5.

### Default and name of terminal

Setup item	Default (function)	Name of terminal
OUT TERMINAL 1	1 (COUNT OK)	COUNT OK
OUT TERMINAL 2	2 (COUNT NOK)	COUNT NOK
OUT TERMINAL 3	3 (TORQUE OK)	TORQUE OK
OUT TERMINAL 4	4 (TORQUE NOK)	TORQUE NOK
OUT TERMINAL 5	5 (SV)	SV

### Setup item

Setting	Name of signal	Function
1	COUNT OK	Count OK signal Signal output duration time is set by COUNT OK of TIMER SETTING.
2	COUNT NOK	Count NOK signal Provide COUNT NOK signal output until COUNT NOK is cleared.
3	TORQUE OK	Torque OK signal Signal output duration time is set by FASTENING OK of TIMER SETTING.
4	TORQUE NOK	Torque NOK signal Provide TORQUE NOK signal output until TORQUE NOK is cleared.
5	SV	Provide the signal output when torque reaches the start torque.
6	TORQUE LOW NOK	Provide the signal output when the torque low NOK judgment is provided.
7	TORQUE HIGH NOK	Provide the signal output when the torque high NOK judgment is provided.
8	OPERATION RANGE	Provide the signal output while the fastening is in process.
9	CPU RUN	Provide the signal output when UEC is in operation. Switch off when UEC gets inoperable status while the setting is overwritten.
10	CAUTION	Caution signal Provide this signal output when the cumulative fastening number or pulse blow number reaches the preset repair fastener number or pulse blow number.
11	WORK A ANSWER	WORK Answer Provide answer output signal of active work No.
12	WORK B ANSWER	
13	WORK C ANSWER	
14	WK 1 COUNT OK	COUNT OK per WORK NO.
15	WK 2 COUNT OK	
16	WK 3 COUNT OK	
17	WK 4 COUNT OK	
18	WK 5 COUNT OK	

Note : It is not possible to assign same signal to two or more terminals.

## 9.7. LAN (LAN setting)

This is to set up for the Ethernet connection.

Set up the values in LAN SETTING screen, and [LAN] is displayed. After you changed the setting values all, please do not press [RES] until [LAN] goes off. It takes approx. 20 seconds.

LAN1 #1 (1/7) →IP ADDRESS 1 0120 IP ADDRESS 2 0000 IP ADDRESS 3 0100	LAN #1 (2/7) →IP ADDRESS 4 0001 SUBNET MASK 0008 DEFULT GATWAY	LAN #1 (3 / 7) →DEFAULT GATWAY 0000 DEFAULT GATWAY 0000 DEFAULT GATWAY 0000
LAN #1 (4/7) →TCP PORT 02101 CONNECT MODE 0001 HOST IP ADDR 0120	LAN #1 (5/7) →HOST IP ADDR2 0000 HOST IP ADDR3 0100 HOST IP ADDR4 0000	LAN#1 (6/7) →REMOTE TCP POR 02101 LAN RETRY NUM. 03 COMM.-LESS TIM 10
LAN #1 (7/7) →MAC ADDRESS *****		

### IP ADDRESS 1 - 4

Default : 120.0.100.1

Setting range : 0 - 255

[Function]

This is to determine the IP address of UEC.

### SUBNET MASK

Default : 0008

Setting range : 1 - 31

Setting:	1	(255.	255.	255.	254)
	8	(255.	255.	255.	0)
	16	(255.	255.	0.	0)
	24	(255.	0.	0.	0)
	31	(128.	0.	0.	0)

[Function]

This is to set up Subnet mask.

### DEFAULT GATEWAY

Default : 0. 0. 0. 0.

Setting range : 0 – 255

[Function]

This is to set the default gateway.

Set up when connecting to PC via router.

### TCP PORT

Default : 2101

Setting range : 0 – 9999

[Function]

This is to set up the TCP port of UEC.

#### CONNECT MODE (Connection mode)

Default : 1

Setting : 0 Set UEC as host

Setting : 1 Set UEC as client

[Function]

Set [0] (UEC as host), when connecting to data base.

Set [1] (UEC as client), when connecting to the UEC-4800 setup software.

#### HOST IP ADDR 1 – 4 (HOST IP address)

Default : 120.0.100.0

Setting range : 0 - 255

[Function]

Enter the IP address of the PC which is used for the setup.

#### REMOTE TCP POR (Remote TCP port)

Default : 2101

[Function]

This is to set up TCP port of PC which communicates to UEC.

Set up with same value of TCP port of UEC.

#### LAN RETRY NUM. (LAN retry number)

Default : 3

Setting range : 0 - 10

This is to determine the retry number to be made.

#### Comm.-less time (LAN nonresponding limit time)

Default : 10

Setting range : 0 - 10

This is to determine the waiting time in case of nonresponding.

#### MAC ADDRESS

Default : Assign unique address

Setting range : 0 - 9999

Mac address of UEC.

Impossible to change the setting value.

## 9.8. Program Number Change

This is to set the program number choice. Maximum 8 kinds (fastening torque, judgment values of torque and angle etc.) of program can be set up within same work number by using the program number change function. It is possible to set up maximum 20 fasteners under same work number. 8 kinds of work number (from program 1 to 8) can be set up for first fastener up to 20th fastener.

Note: This function is available in UEC-4800 version 1.15 and later version.

PROGRAM SEL 1 1/8) →PROGRAM NO SEL 0 PROGRAM NO SW 1 FIRST 0	PROGRAM SEL 1 (2/8) →SECOND 0 THIRD 0 FOURTH 0	PROGRAM SEL 1 (3/8) →FIFTH 0 SIXTH 0 SEVENTH 0
PROGRAM SEL 1 (4/8) →EIGHTH 0 NINTH 0 10 <sup>TH</sup> 0	PROGRAM SEL 1 (5/8) →11 <sup>TH</sup> 0 12 <sup>TH</sup> 0 13 <sup>TH</sup> 0	PROGRAM SEL 1 (6/8) →14 <sup>TH</sup> 0 15 <sup>TH</sup> 0 16 <sup>TH</sup> 0
PROGRAM SEL 1 (7/8) →17 <sup>TH</sup> 0 18 <sup>TH</sup> 0 19 <sup>TH</sup> 0	PROGRAM SEL 1 (8/8) →20 <sup>TH</sup> 0	

### PROGRAM NO SEL (Program number change select)

Default : 0

Setting : 0 Not use

Setting : 1 Use, and program number is selected by signal input from terminal of UEC.

Setting : 2 Select program number by the 32 byte data received on the serial port on the rear panel.

Set 1 to ID DATA OUT, and set 32 to ID DATA NUMB in the DATA OUT SETTING screen.

Setting : 3 Receive work number signal from 48 byte data received on the serial port on the rear panel.

Set 1 to ID DATA OUT, and set 48 to ID DATA NUMB in the DATA OUT SETTING screen.

#### 【Function】

- This is to determine whether use or not the program number choice, and how to change program number.
- When setting value is changed from 0 to any of 1 – 3 or vice versa, UEC clears memory data. It is because UEC memorizes program number when program number choice is used.

### PRGRAM NO SW (Program number change switch)

Default : 0

Setting : 0 Switch to next work number only when UEC provides fastening OK.

Setting : 1 Switch to next work number whichever UEC provides fastening OK/NOK.

Setting : 2 Switch to next work number when UEC provides OK or torque HIGH NOK.

#### 【Function】

- This is to determine the condition to have UEC switched to next work number when program number choice is used.

## FIRST – 20TH FASTENER

Default : 0

Setting range : 0 - 8

Setting : 0          Fastening is ended.

1 – 8 :      Fastening is performed per setting of selected work number.

### 【Function】

- This is to determine which fastener is fastened by which setting of work number.

### 【Setting example】

Set either 1 or 2 to PROGRAM NO SEL, and set 1 to First, Second and Third fastener, and 2 to Fourth fastener. First, second and third fastener is fastened up to CUT values of WORK 1 setting, and judged in accordance to WORK 1 setting. Fourth fastener is fastened in accordance to WORK 2 setting. Set 0 to fifth fastener and set 4 to COUNT of BASIC SETTING, if the fastening is ended with fourth fastener.

When either 1 or 2 is set to PROGRAM NO SEL, it is possible to fasten up to 20 fasteners. It is possible to set up work number to each fastener from first up to 20th.

Work number combination is settable with maximum 8 kinds from program 1 to 8.

When 3 is set to PROGRAM NO SEL, work number combination and fastening number are decided and received from the serial port on the rear panel.

PROGRAM SEL	3	(4/8)
→EIGHTH		0
NINTH		0
10th		0

Select the program number you want to set up parameters. Selectable from the program number 1 upto 8.

## 9.9. MEMORY DATA

This is to set up the setting of memory data and the display or the clear of the calculated value from the memory data.

MEMORY DATA (1/3)	MEMORY DATA (2/3)	MEMORY DATA (3/3)
AVR. 000.0	CP 00.00	→MEM.CONTENTS 2
→σ 00.00	→CPK 00.00	MEMORY CLEAR 0
3σ +/-% 00.00	MEMORY BLOCK 3	UNUS.HIST.CL 0

AVR (Average value) (former name: MODE 82)

Function

- Displays average value of memorized data

Note: This is not a setting value.

$$\bar{x} = \frac{x_1 + x_2 + \dots + x_n}{n}$$

$\bar{x}$  : Average

n : Data number

σ (σ value) (former name MODE 83)

Function

- Displays σ value of memorized data

Note: This is not a setting value.

$$\sigma = \sqrt{\left[ \frac{1}{n-1} \sum (x_n - \bar{x})^2 \right]}$$

σ: Standard deviation

3σ+/- (3 σ value / Average value plus-minus % value / former name MODE 84)

Function

- Displays the 3σ / Average value (deviation value) of the memorized data

$$3\sigma \text{ value} = \frac{3\sigma}{\bar{x}} \times 100\%$$

3σ value : Rate of variability

CP (CP value / former name MODE 85)

Function

- Displays CP value of memorized data
- Displayed value is calculated one from the selected work number setting value (torque high and low limit value)

Note: This is not a setting value.

$$CP = \frac{\text{Upper limit} - \text{Lower limit}}{6\sigma}$$

CP = Process Capability Index

CPK (CPK value / former name MODE 86)

- Displays CPK value of memorized data
- Displayed value is the calculated one from the selected work number setting values (torque high and low limit value).

Note : This is not a setting value.

$$CPK = \frac{B}{3\sigma}$$

B1 : Upper limit – Average

B2 : Average – Lower limit

B : Smaller value between B1 and B2

CPK : Process Capability Index (deviation of average inclusive)

MEMORY BLOCK (Memory data block / former name : MODE 87)

Default : 3

Setting: 1 UEC stores data of work number all in one without time/date and ID number.  
(Maximum 12,000 pcs.)

Setting: 2 UEC stores data per work number without time/date nor ID number.  
(Maximum 1,500 pcs.)

Setting: 3 UEC stores data of work number all in one including time/date, but without ID number.  
(Maximum 5,400 pcs.)

Setting: 4 UEC stores data per work number including time/date, but without ID number.  
(Maximum 680 pcs.)

Setting: 5 UEC stores data of work number all in one including time/date and ID number.  
(Maximum 2,200 pcs.)

Setting: 6 UEC stores data per work number including time/date and ID number.  
(Maximum 270 pcs.)

**【Function】**

- This is to determine whether per work number or work number 1 -8 all in one, and whether include time/date and ID number UEC stores the data.
- When the data is stored per work number, the storable maximum data becomes 1/8 of the one stored by batch. UEC drops old data to memorize new data one by one after the data storage comes to the maximum.
- When the data is stored with time/date, the storable maximum data becomes approx. 1/2.
- UEC calculates average value, CPK value etc. per block.

#### MEM. CONTENTS (memory content / form name MODE 88)

Default : 0

Setting : 0 Not memorize the fastening data

Setting : 1 Memorize all fastening data

UEC provides warning by the buzzer and the warning display [COUP] when the data storage comes to the last 10 pieces to maximum memory. Switch on RESET terminal, or press the reset key, and the display will go off. But UEC provides warning with same way, if you continue fastening.

Setting : 2 Same as the setting 1, but not provide the warning of the maximum memory.

Setting : 3 Memorize only OK data and provide the warning of the maximum memory



Setting : 4 Same as the setting 4, but not provide the warning of the maximum memory

#### Function

- This is to determine what to memorize and whether to warn the maximum memory when the data storage comes to the last 10 pieces to maximum memory.
- All memorized data is cleared when the setting value is changed.

#### MEMORY CLEAR (clear of the memorized data / form name MODE 89)

#### Function

- When it is set to [1], UEC clears all the memorized data of the specified work number.
- [-CLE] is displayed on the display and press  again to execute the data clear.
- Same can be done through PC by pressing  in the statistic screen of the setup software.

#### UNUS. HIST. CL (clear the unusual history)

#### 【Function】

- Set to [1] to clear the history of the error or trouble like CAL error, ZERO error etc. (other than the errors included in the fastening data) memorized in UEC-4800.

## 10. Functions

### 10.1. Fastening control

Fastening control method is selectable from 5 options.

- Control method : 1 Torque monitor
- : 2 Torque control
- : 3 MC/EC wrenches Torque control
- : 9 T type wrenches Torque monitor

#### 1) Torque monitor Control method : 1

This is used mainly for torque monitoring of the angle nutrunner UAN series, which shuts off by mechanical clutch. When 1 is set to EXTERNAL START, UEC starts torque measuring by the external start signal input. When 0 is set to EXTERNAL START, UEC starts torque measurement when detecting the start torque or greater torque and provides the judgment when the judgment delay timer comes up after the torque gets lower than the start torque.

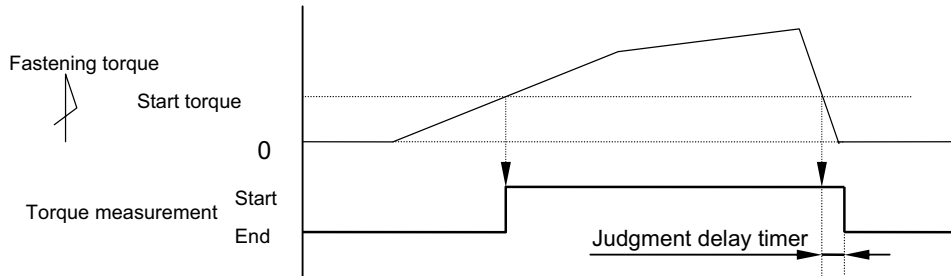

#### 2) Torque control Control method : 2

This is mainly used for torque control of nutrunner. UEC switches on VALVE terminal to have nutrunner operated and controls its torque. Switching on external start signal, nutrunner operates and UEC starts torque measurement. Nutrunner continues operating until torque reaches CUT torque. UEC provides judgment when judgment delay timer comes up after the torque gets lower than start torque.

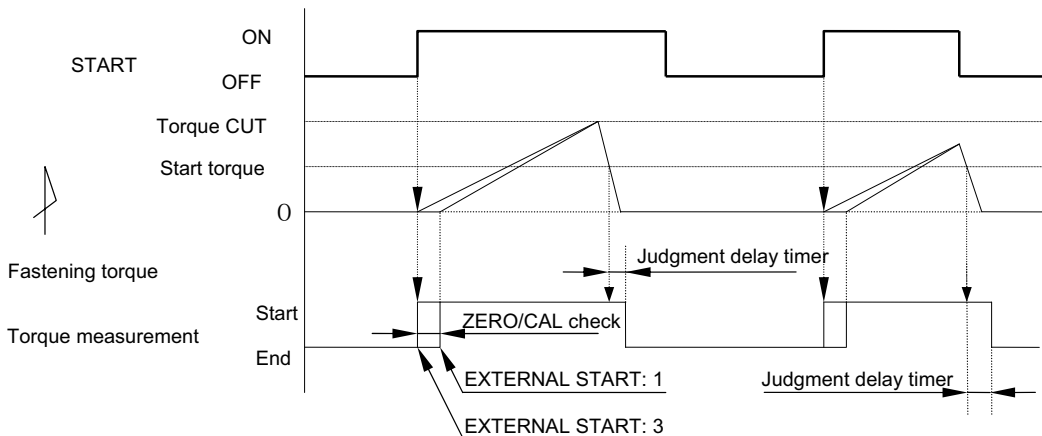

3) MC/EC wrenches Torque control Control method : 3

This is to control torque of either MC or EC wrenches. UEC starts torque measurement when detecting the start torque or greater torque, and switches on valve terminal to stop the tool when reaching torque cut level. UEC provides judgment when judgment delay timer comes up after torque gets lower than start torque.

When torque measurement delay timer is set up, it starts functioning when detecting start torque or greater torque. UEC cancels torque spike at the bolt seating point by suspending torque measurement until torque measurement start delay timer comes up, and then starts torque measurement.

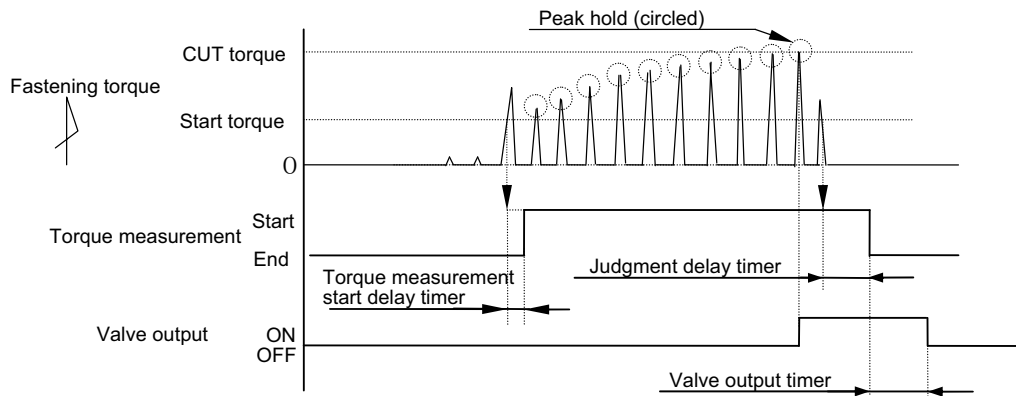

5) T type wrenches Torque and fastening time monitor Control method : 9  
 UEC monitors torque and fastening time of shut off tools.

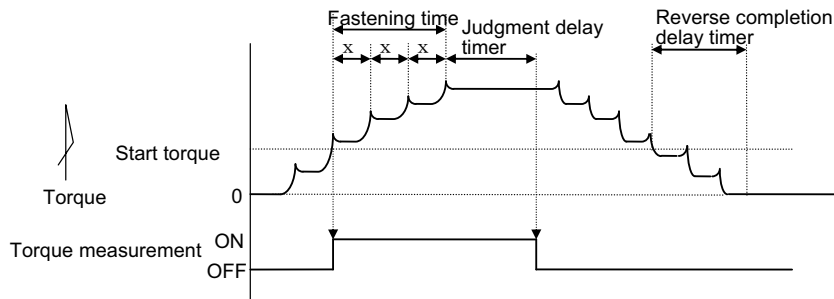

UEC starts torque measurement when detecting the start torque or greater torque, judges the tool is shut off when provides judgment when the fastening time between peak torque (x in a graph) gets longer than the judgment delay timer, and provides judgment.

After UEC provides judgment, reverse completion delay timer gets functioning when the residual load torque gets lower than start torque by the tool's reverse operation. Timer timeout is regarded as the completion of tool reverse operation, UEC switches off VALVE to cancel the tool's operation start.

#### Fastening time

- (1) Fastening time measurement start point
  - When torque reaches start torque
- (2) Fastening time measurement end point
  - A point is determined by deducting the judgment delay timer off time from the time required until judgment output.

## 10.2. Upper and Low limit judgement

UEC provides judgment whether or not the detected torque, angle or pulse number is within upper and low limit.

Upper and low limit judgment is made against torque or pulse numbers until fastening is completed. Upper and low limit of torque is set in [TORQUE LOW] and [TORQUE HIGH] in the BASIC SETTING screen.

Upper and low limit of pulse number is set in [PULSE LOW (pulse blow number lower limit)] and [PULSE HIGH (pulse blow number higher limit)] in the MODE SETTING screen.

[Judgment]

- (1) OK judgment when the measurement value is within upper and low limit. (OK)
  - Front panel OK LED lamp lights in green.
  - Tool's LED lamp will light in green.
  - UEC output TORQUE OK.
  - When 1 is set to ALARM BUZZER, UEC gives single sounding "Pi" for each fastener OK result, and double sounding "Pi-Pi" for COUNT OK.
  
- (2) HIGH NOK judgment when the measurement is confirmed higher than upper limit. (TORQUE HIGH NOK)
  - Front panel HIGH LED lamp lights in red.
  - Tool's LED lamp lights in red.
  - Buzzer sounds.
  - UEC outputs TORQUE NOK.
  - UEC outputs TORQUE HIGH.
  
- (3) Judgment when pulse number is greater than pulse number upper limit.
  - Front panel displays [PLS.H] and [Torque measurement value] by turns.
  - Tool's LED lamp lights in red.
  - Buzzer sounds.
  - UEC outputs TORQUE NOK.
  
- (4) LOW NOK judgment when the measurement is confirmed lower than low limit. (TORQUE LOW NOK)
  - Front panel LOW LED lamp lights in yellow.
  - Tool's LED lamp lights in yellow.
  - Buzzer sounds.
  - UEC outputs TORQUE NOK.
  - UEC outputs TORQUE LOW NOK.
  
- (5) Judgment when pulse number is less than pulse number low limit. (PULSE LOW NOK)
  - Front panel displays [PLS.L.] and [Torque measurement value] by turns.
  - Tool's LED lamp lights in yellow.
  - Buzzer sounds.
  - UEC outputs TORQUE NOK.

### 10.3. Torque change degree zone monitor

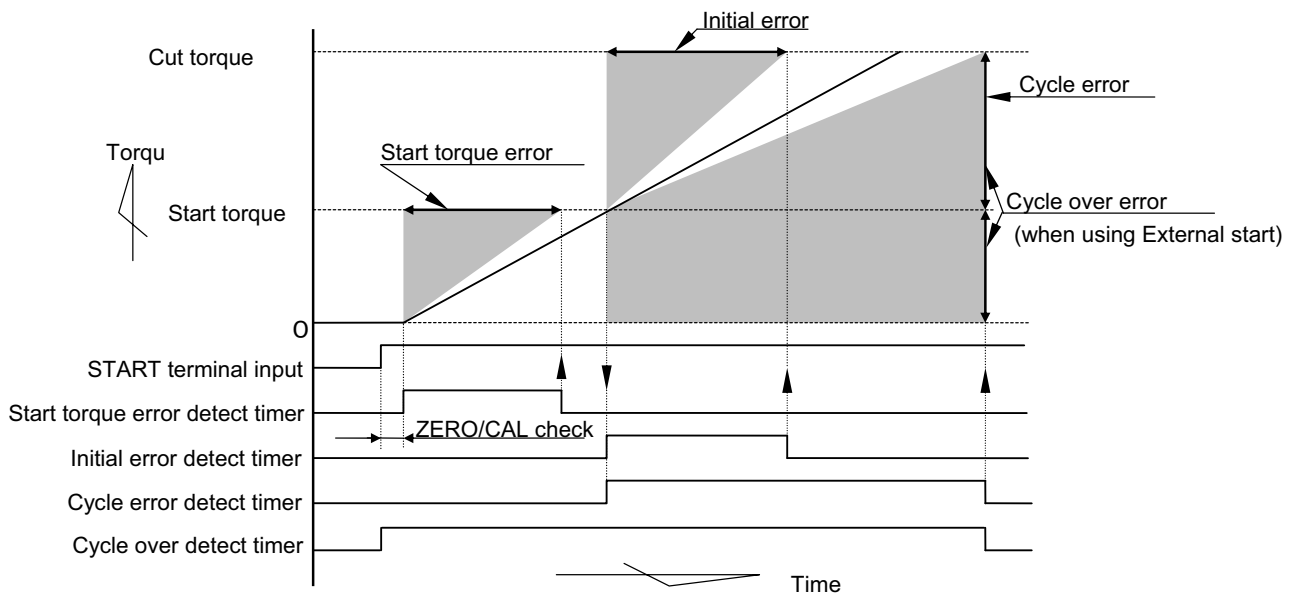

Note ) Above is an example of linear torque change curve.

#### 1) Start torque error [S.L.E.]

UEC detects the time from the time when external start terminal is switched on till the torque reaches start torque, and provides the judgment if the torque reaches start torque before the start torque error detect timer comes up.

[Note]

- UEC could not detect the error if the preliminary fastening condition varies much per bolt or nut.
- UEC could not detect the error when it takes long to fit the nutrunner socket to work piece.

[Setting value]

- ST. TORQUE ERROR detection : 1
- ST. TORQUE ERROR detection timer : 1 – 9999 [msec]

[How to set]

- Monitor the time from external start input to start torque of the correct fastening, and determine the setting value. The time is displayed on TIGHTENING (TSS) of the MODE SETTING screen (page 5/10).

2) Initial error [LO.E.]

UEC provides the error when the time from start torque to cut torque is shorter than the time of initial error detect timer.

[Setting value]

- Initial error detect select: 1
- Initial error detect timer : 1 – 9999 [msec]

[How to set]

- Determine the setting value by monitoring the time from start torque to cut torque of the correct fastening.

3) Cycle error [CYL.E.]

UEC provides the error when the time from start torque to cut torque is longer than the time of cycle error detect timer.

[Setting value]

- Cycle error detect select : 1
- Cycle error detect timer : 1 – 9999 [msec]

[How to set]

- Determine the setting value by monitoring the time from start torque to cut torque of the correct fastening.

4) Cycle over error [CYO.E.]

UEC provides the error when judgment is not made from START terminal input till the cycle over error detect timer comes up.

This is used for detecting the idling of nutrunner when a socket is not fit into a work piece.

[Setting value]

- Cycle over error detect: 1
- Cycle over error detect timer : 1 – 9999[msec]

[How to set]

- Determine the setting value with time to spare by monitoring the time from START terminal input to judgment output of the normal proper fastening.

## 11. Torque Sensor Wiring Diagnosis

UEC makes torque sensor cable's damage, break or short circuit. The error detection is made when ZERO/CAL check is in action.

### 11.1. Error detection

#### 1) ZERO check

UEC checks how big the voltage of torque sensor will change from 0(V) under no load condition. UEC detects ZERO error if the voltage variation (DPM display zero point) becomes out of the range of plus minus 6% of the rated torque.

#### 2) CAL check

UEC checks whether sensor setting value in UEC is appropriate to the connected torque sensor's wiring and the specifications. UEC checks if the torque sensor output signal is within  $100 \pm 6\%$  of the CAL value by applying simulative electric pressure to the torque sensor so as to put the torque sensor in the virtual condition under rated load strain.

UEC detects Cal error if the torque sensor is not connected with UEC correctly, or its wiring and the specifications does not fit to UEC set up.

### 11.2. ZERO/CAL check perform timing

- When self-diagnosis function is running by switching on UEC.
- When  is pressed or RESET terminal is switched on.
- When START terminal is switched on. (In case when either 0 or 1 is set to EXTERNAL START.)
- When [F6 ZERO CAL] on the ZERO POINT ADJUSTMENT screen of the UEC-4800 setup software is pressed.

When error is detected

- ZERO error : [0.E.] and [Torque measurement value] are displayed alternately.
- CAL error: [CAL.E.] and [Torque measurement value] are displayed alternately.
- Buzzer sounds.
- TORQUE NOK terminal is switched on.

## 12. Auto ZERO

This is a function to do correct torque value measurement by doing automatic correction measured torque variation due to torque sensor's ZERO point deviation. UEC memorizes ZERO point deviation confirmed by ZERO/CAL check, includes the deviation degree in torque sensor signal, and converts the adjusted torque signal to torque value. This auto ZERO will not function when ZERO/CAL error occurs.

Examples of AUTO ZERO

1) When ZERO/CAL check detects plus (+) side deviation.

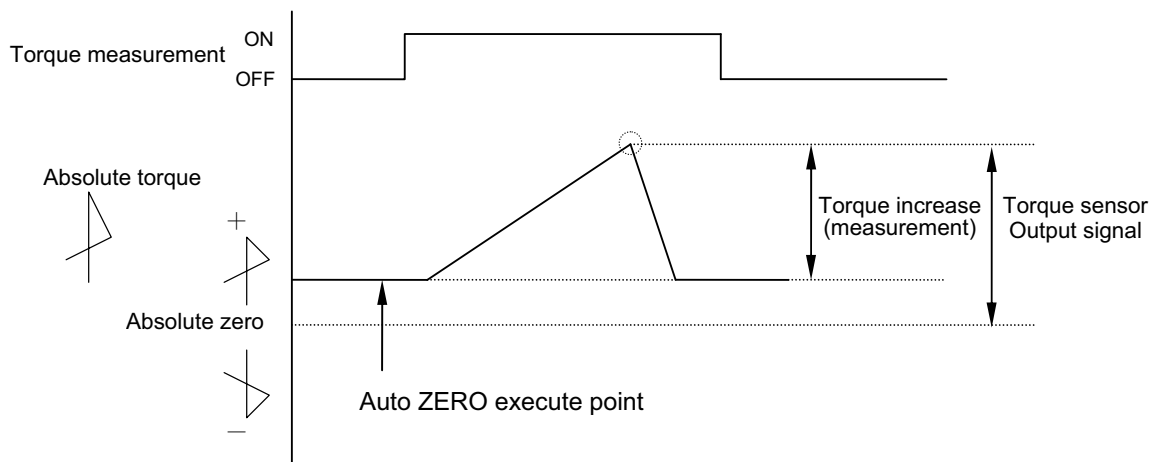

2) When ZERO/CAL check detects (-) side deviation

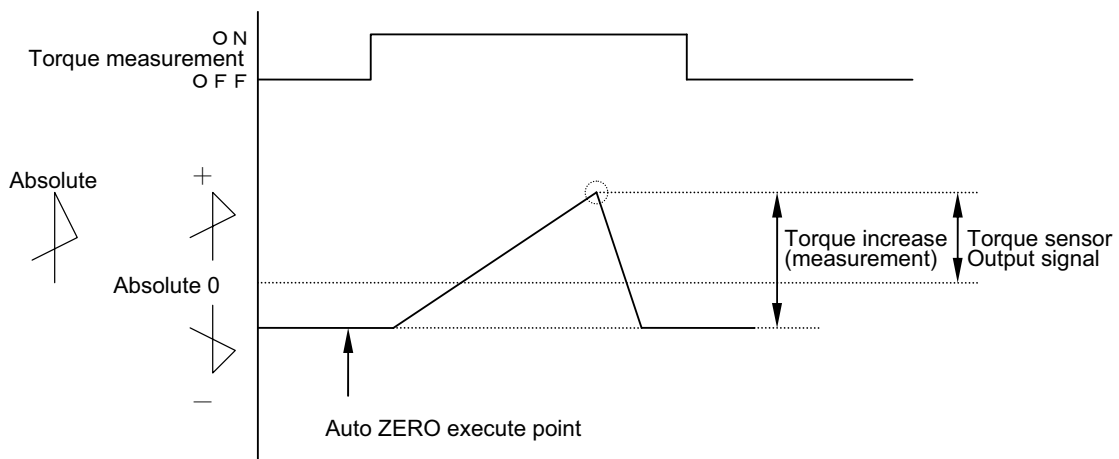

Auto ZERO execute timing

UEC executes AUTO ZERO after ZERO/CAL check.

- At the time of self-diagnosis when UEC is switched on.
- When pressing **RES**, or RESET TERMINAL is switched on.
- When START is switched on

### 13. Torque waveform measuring procedure

Following explains how to measure the torque waveform by using the memory hicorder or memory scoop.

- 1) Make sure that the setting values are correctly set up. Check especially that the specifications of the torque sensor connected to the UEC-4800 agrees to the setting value of the torque sensor, and the CAL value is set up correctly.
- 2) Connect the waveform measurement equipment to UEC-4800.

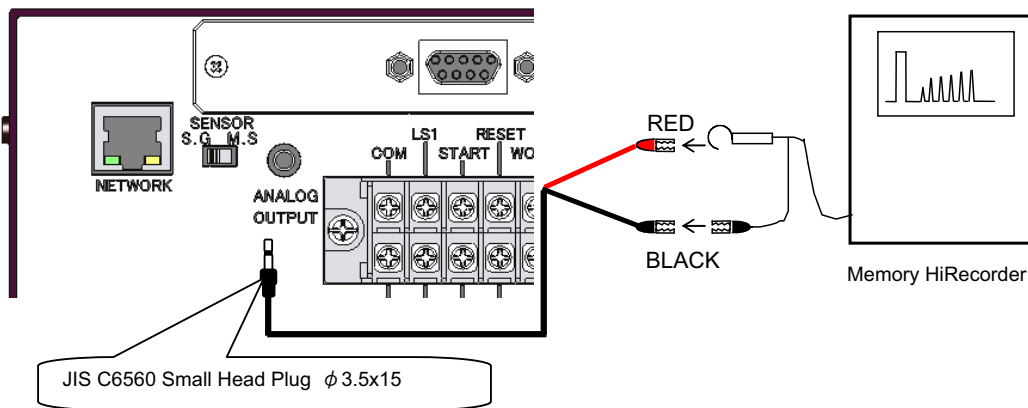

Note) UK-PLUG's red wire : torque signal  
UK-PLUG's black wire : 0V (GND)

- 3) Press **RES** to have the UEC-4800 measure CAL waveform height (rated torque applied electric pressure). UEC-4800 makes the CAL check.
- 4) Confirm CAL waveform height, and then set and adjust waveform measurement equipment.
- 5) Perform torque waveform measurement.

## 14. ANALOG OUTPUT terminal

UEC outputs the analog torque signal voltage in real time by having the torque sensor output signal voltage amplified by 1000 times, filtered and attenuated.

### 1) Torque sensor output voltage specification table

Following is output voltage (x V) when rated load torque is applied to torque sensors. Output voltage changes per sensor specifications.

Torque sensor specifications		ANALOG output voltage (x V)
480 Ω	2000x10 <sup>-6</sup>	DC 1.5V
700 Ω	750x10 <sup>-6</sup>	DC 0.75V
700 Ω	1500x10 <sup>-6</sup>	DC 1.5V
700 Ω	1600x10 <sup>-6</sup>	DC 1.6V
350 Ω	2000x10 <sup>-6</sup>	DC 1.5V
350 Ω	4000x10 <sup>-6</sup>	DC 1.5V
Magnetostrictive type sensor		DC 1.5V

### 2) How to convert analog output voltage to torque value

$$\text{Torque Value} = \frac{\text{Output voltage when strained by fastening} (\Delta V)}{\text{Output voltage when applied rated load} (\chi V)} \times \text{Rated torque value}$$

### 3) Analog output terminal specifications

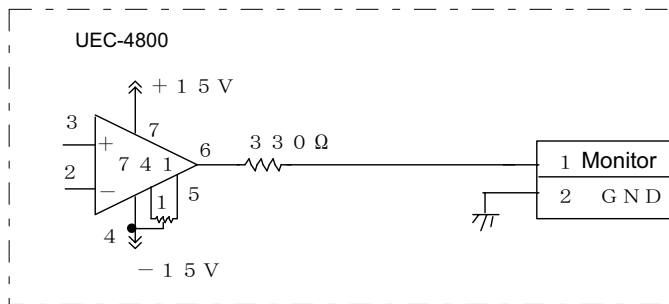

### 4) Analog output terminal

Plug size : JIS C6560 single small head plug ø3.5x15

## 15. Error

### 15.1. Error message & contents

**ZERO Error: [ *0.E.* ] and [NG measurements] are displayed alternately.**

- When more than  $\pm 6\%$  deviation off from rated value is detected.

**CAL Error: [ *CALE.* ] and [NG measurements] are displayed alternately.**

- When more than  $100\pm 6\%$  deviation off from rated value is detected

**Buffer Full Error: [ *buf.E.* ] and [Torque measurements] are displayed alternately.**

- This error is fired when more angle data to a buffer than the memory unit can accommodate is flowed into it (buffer overflow). The memory capacity is programmable on mode settings of "WAVEFORM MEMORY FUNCTION SELECT". If it is set to either 1 or 4, this message does not come up.

**Setting Error: [ *SE.* ] is displayed.**

- When not settable setting value is input. When the setting value is out of the setting range or interlock value is input.

**Pulse Number LOW NOK: [ *PLSL.* ] and [Torque measurements] are displayed alternately.**

- When the pulse number is less than pulse number low limit.

**Pulse Number HIGH NOK: [ *PLSH.* ] and [Torque measurements] are displayed alternately.**

- When the pulse number is over than pulse number high limit.

**Initial Error: [ *LOE.* ] and [NG measurements] are displayed alternately.**

- When fastening torque reaches CUT torque before initial error detection timer comes up.

**Cycle Error: [ *CYLE.* ] and [NG measurements] are displayed alternately.**

- When fastening torque does not reach CUT torque before cycle error detection timer comes up.

**Fastening Suspension Error: [ *FE.* ] is displayed.**

- When the fastening is suspended before the torque reaches CUT torque.

**Start Torque Error: [ *SLE.* ] is displayed.**

- Start torque error detect timer starts functioning when start terminal is switched on. When the torque does not reach start torque before this timer comes up.

**Cycle Over Error: [ *CYOE.* ] is displayed.**

- Cycle over error detect timer starts functioning when start terminal is switched on. When the fastening operation (judgment) is not completed before this timer comes up.

**Warning Count Number Error: [ *tcHE.* ] is displayed.**

- When the total fastening cycle reaches the warning cycle setting value.

**Warning Pulse Number Error: [ *tcPE.* ] is displayed.**

- When the total fastening pulse number reaches the warning pulse number setting value.

**Repair Count Number Error: [ *rPHE.* ] is displayed.**

- When the total fastening cycle reached the repair number setting value.

**Repair Pulse Number Error: [ *rPPE.* ] is displayed.**

- When the total pulse number reaches the repair pulse number setting value.

**Warning Memory Error: [ *COUP* ] is displayed.**

- When the memory remaining volume gets less than -10 from the maximum memory data.

**ROM Error: [ *Er.01* ] is displayed.**

- When ROM of board is broken down or causes malfunction for some reasons.

**RAM Error: [ *Er.02* ] is displayed.**

- When RAM of board is broken down or causes malfunction for some reasons.

**A/D Error: [ *Er.03* ] is displayed.**

- When A/D of board is broken down or causes malfunction for some reasons.



**SUM Check Error: [ *Er.05* ] is displayed.**

- When the setting data memorized in RAM have error.

#### Blown Fuse

- 1) When the AC fuse (Refer to 4.2 Rear panel ②) is blown, UEC cannot be powered on.
- 2) When the DC24V fuse on the board inside UEC housing is blown, following phenomenon occurs.
  - LED of the power switch does not light.
  - Tool does not shut off even if the fastening torque gets over the cut level.
  - Tool's lamp does not light.

## 15.2. Recommended Action

Error	Countermeasure
ZERO error	<ul style="list-style-type: none"> <li>Be sure to set the select switch, [M.S] or [S.G], in UEC rear panel (refer to 4.2 Rear Panel 5)</li> </ul>
CAL error	<ul style="list-style-type: none"> <li>Replace a tool and sensor cable.</li> <li>Get the sensor values to agree with the torque sensor connected.</li> <li>Check if the tool is running during the checking is being made.</li> </ul>
Buffer Full error	<ul style="list-style-type: none"> <li>Check the communicating cable.</li> <li>Set the setting of WAVEFORM MEMORY FUNCTION SELECT to 4.</li> </ul>
Setting error	<ul style="list-style-type: none"> <li>Check and correct the mode settings parameters to see they are logically correct like the formula START&lt;CUT.</li> </ul>
Initial/Cycle error	<ul style="list-style-type: none"> <li>Check any possible double-fitting and/or cross thread fastener.</li> </ul>
Pulse number LOW/HIGH	<ul style="list-style-type: none"> <li>Check the alignment of workpiece and bolt.</li> <li>Check start torque and cut torque values.</li> </ul>
Fastening angle LOW/HIGH	<ul style="list-style-type: none"> <li>Check the timers for initial torque spike/cycle incomplete error. *1</li> <li>Check the pulse low/high limits. *1</li> </ul>
Fastening suspension error	<ul style="list-style-type: none"> <li>Check the tool performance and air pressure applied to tool.</li> <li>Check the judgement delay timer is long enough.</li> <li>Be sure not to release the trigger before the tool reaches the CUT level.</li> </ul>
Start torque error	<ul style="list-style-type: none"> <li>Check the alignment of workpiece and bolt.</li> <li>Check the tool performance and air pressure applied to tool.</li> <li>Check the start torque and start torque error detect timer is correctly set.</li> </ul>
Cycle over time error	<ul style="list-style-type: none"> <li>Check the tool performance and air pressure applied to the tool.</li> <li>Check the setting value of cycle over error detect timer is correctly set.</li> </ul>
Warning count/pulse number error	<ul style="list-style-type: none"> <li>Recondition the tool like oil change and set the count/pulse number for the next maintenance due time.</li> </ul>
Repair count/pulse number error	<ul style="list-style-type: none"> <li>Repair or replace a tool, and clear the repair count / pulse number.</li> </ul>
Warning memory error	<ul style="list-style-type: none"> <li>Download and store the data in the UEC-4800 memory, and then clear the memorized data.</li> <li>Review the setting value of MEMORY DATA CONTENTS if this function is not needed.</li> </ul>
ROM/RAM error	<ul style="list-style-type: none"> <li>Replace the UEC-4800.</li> </ul>
A/D error	<ul style="list-style-type: none"> <li>Replace the tool or the UEC-4800.</li> </ul>
Sum check error	<ul style="list-style-type: none"> <li>If UEC works in order again by switching on or pressing , memory can be overwritten by noise. Set all the setting values again as the previous setting values are initialized when UEC is recovered by switching on or pressing .</li> </ul>
Blown DC24V Fuse on the PC board	<ul style="list-style-type: none"> <li>Check the wiring and replace the fuse (model: MH10(1) code number: 909-814-0 maker: Daitoh tushinki). Make sure to switch off and disconnect the power cable from AC power receptacle when replacing the fuse.</li> </ul>

\*1: Decide the values referring to the fastening time from start torque to cut level, blow numbers and angle for good tightening.

## 16 Networking

The controller has several networking options available including Ethernet and hardwired field bus. All parameters pertaining to networking are configured in the web interface via its Ethernet.

### 16.1 Ethernet

Each Ethernet connection can be configured to communicate with most popular plant equipment including data collection servers, laptop software, and PLCs.

Ethernet ports by default are set to an IP address of 10.10.30.150 and need to be changed before being put into service.

To gain initial access to the controller:

- Configure a computer's Ethernet port to an IP address of 10.10.30.xxx. Do not set it to 10.10.30.150 that address is assigned to the controller. 10.10.30.99 works in most cases.
- Connect an Ethernet crossover cable from the computer to the controller.
- Launch the computers web browser. Type the controller IP address (10.10.30.150) into its address bar.
- Navigate to the communications page.
- Set the desired IP Address, IP Mask, and Gateway.
- Cycle power on the controller and connect it to the network.

#### 16.1.1 Web Interface

The controller's web interface is available from any computer on that has access on the local network. To access the web interface launch a browser and type the controller IP address into its address bar.

From the interface you will have access to the controller's status, internal data files, and parameters. The pages do not automatically refresh but selecting refresh from the browser will reload the latest information from the controller. Data files will be standard ASCII text in CSV (comma separated variables) format that can be opened in Microsoft Excel and other programs.

On pages with parameters there will be a submit button to apply any changes. All parameters on the page are submitted when the button is hit. When submitted each parameter will get range checked against allowable limits. If a parameter is outside of its range it will be limited to its minimum or maximum value. When the page is redrawn the edit fields will contain each parameters final value.

#### 16.1.2 Security

The web interface has an option to add a user password for security. A password is never required to view the web pages on the controller. It is only required to make a change to a parameter. If the controller password is not set (a zero length string) the user will not be prompted to enter a password for any changes. The controller is shipped from the factory without a password.

The security feature utilizes the authentication built into the browser. When a change to a parameter is made the controller checks the programmed password. If a password is required the controller will request it from the browser and in turn the browser will prompt the user. The browser will request a "User name" and "password". Since the controller only contains one password (one user) the "User name" can be left blank. Once the password is entered it is returned to the controller where it will be checked and if it is correct the parameters are saved. If it is incorrect the controller will request it from the browser again.

After a password has been entered most browsers will cache it and return on subsequent request without prompting the user. So as long as the browser is not closed it would not be necessary to enter the password on every change to the parameters.

To remove a password from the controller it just needs to be set to a zero length string and saved via the submit button. Of course this action requires the existing password. If the password is lost or unknown contact your AIMCO representative for a method of retrieval.

### 16.1.3 Toolsnet

The controller has the ability to send rundown data to a ToolsNet server. Once the controller is on the local network there are five parameters that must be set to store data correctly on the server.

1. **Server IP Address:** This is the IP address of the Toolsnet server. If the server is on another subnet you will also have to verify the gateway in the Ethernet settings.
2. **Server Port Number:** This is the TCP port the server is listening on for a new connection. The default for this is 6547 but it should be verified with the local Toolsnet server administrator.
3. **Station Id:** This is used to identify the data in the Toolsnet database. Work with your local Toolsnet server administrator to set this correctly.
4. **System Number:** This is used to identify the data in the Toolsnet database. Work with your local Toolsnet server administrator to set this correctly.
5. **Station Number:** This is used to identify the data in the Toolsnet database. Work with your local Toolsnet server administrator to set this correctly.

### 16.1.4 Open Protocol

The controller has the ability to accept an "Open" protocol connection. This connection is available over Ethernet and/or the standard serial ports. Through this connection you can enable/disable the tool, set the active parameter set, collect rundown data, and much more.

1. **Port Number:** The TCP port number the controller listens on to accept an Open protocol connection via Ethernet. The default port is 4545 but can be changed if required.
2. **Cable Loss Detection:** Only used for a serial Open protocol connection. If set to 1 the controller will close the connection on a time-out. If it is set to 0 the controller will not close the

connection. See the latest Open protocol specification for details on time-outs and keep alive messages.

3. **Cell ID:** Optional variable that is passed through the Open protocol connection.
4. **Channel ID:** Optional variable that is passed through the Open protocol connection.
5. **Controller Name:** Optional variable that is passed through the Open protocol connection.

To set up a serial port for Open protocol set the function on the desired COM port to “Open Protocol” and cycle the power on the controller.

The Controller supports the following MIDs. See the latest Open protocol specification for details on each MID.

MID	Description	Note
0001	Communication start	
0003	Communication stop	
0010	Parameter set numbers upload request	
0018	Select Parameter set	
0020	Reset Parameter set batch size	
0042	Disable tool	
0043	Enable tool	
0050	Vehicle Id Number download request	
0060	Last tightening result data subscribe	Rev 1-2 and 999 supported
0063	Last tightening result data unsubscribe	
0070	Alarm subscribe	
0073	Alarm Unsubscribe	
0080	Read time upload request	
0082	Set Time in the Torque Controller	
9999	Keep alive message	

### 16.1.5 AIMCO Database

The controller has the ability to send rundown data to an AIMCO data collection server. Once the controller is on the local network there are two parameters that must be set to store data correctly on the server.

1. **Server IP Address:** This is the IP address of the AIMCO data collection server. If the server is on another subnet you will also have to verify the gateway in the Ethernet settings.
2. **Server Port Number:** This is the TCP port the server is listening on for a new connection. See your local AIMCO data collection server administrator for the correct port number.

### 16.1.6 Modbus TCP

The controller will accept a connection from a Modbus TCP master.

### 16.1.7 Controller Outputs

The Controller's outputs are located at address 0 and contain one status word.

Controller Outputs																
Bits																
	15	14	13	12	11	10	9	8	7	6	5	4	3	2	1	0
Address 0	Handshake			Job Complete			Healthy	Running	Process number							

Bit	Name	Function
0-7	Process Number	Process number echo. Latched while it is in a job.
8	Running	Indicates the tool is running.
9	Healthy	Indicates the controller has no faults.
10	Not used	
11	Not used	
12	Job Complete	Indicates the job is complete. Will go off when Enable input goes off.
13	Not used	
14	Not used	
15	Handshake	Echo of the Handshake input

### 16.1.8 Controller Inputs

The Controller inputs are located at address 1024 and 1036. Address 1024 contains one control word and 1036 contains the 20 character VIN.

		Controller Inputs															
		Bits															
		15	14	13	12	11	10	9	8	7	6	5	4	3	2	1	0
Address 1024	Handshake							Abort	Enable	Process number							

Bit	name	Function
0-7	Process Number	Process number input. The enable must be off to change the Process Number. On a change to the Process Number the batch is also reset.
8	Enable	On the rising edge of Enable the tool will be enabled.
9	Abort	If Abort is on the tool will be disabled.
10	Not used	
11	Not used	
12	Not used	
13	Not used	
14	Not used	
15	Handshake	Will be echoed to the Handshake output

## 16.2 Profibus/DeviceNET

The controller can have an optional Profibus or DeviceNET interface. These interfaces are accomplished through the use of a serial bridge. The serial bridge is provided by *MKS Instruments, Inc.* See the latest MKS documentation for details on sending and receiving messages.

### 16.2.1 Logical I/O

The controller has five status bytes of outputs.

		Controller Outputs							
		Bit							
		7	6	5	4	3	2	1	0
Byte	0							Tool Ready	Tool Enable
	1				Bypass	Batch Complete	Msg Received	Status NOK	Status OK
	2								
	3		Buzz Slow	Buzz Fast	Red	Yellow	Green	Blue	White
	4			Pause	Red Flashing	Yellow Flashing	Green Flashing	Blue Flashing	White Flashing

Byte	Bit	Name	Function
0	0	Tool Enable	The enabled state of the tool.
	1	Tool Ready	On if the tool is ready to run. Will be off if tool is disabled or there is a fault on the controller.
	2-7	Not used	
1	0	Status OK	Rundown status on for an accept. This bit is timed and will be on for ½ second.
	1	Status NOK	Rundown status on for a reject. This bit is timed and will be on for ½ second.
	2	Msg Received	On to indicate a message has been received from the MKS module and the inputs have changed. This bit is timed and will be on for ½ second.
	3	Batch Complete	Indicates the batch is complete. Will go off when batch is reset or when the tool enable is turned off.
	4	Bypass	State of the bypass input.
	5-7	Not used	
2	0-7	Not used	
3	0-6	Light Tower Status	Bitwise status of the Light Tower lights.
	7	Not used	
4	0-5	Light Tower Status	Bitwise status of the Light Tower lights.
	6-7	Not used	

		Controller Inputs							
		Bit							
		7	6	5	4	3	2	1	0
Byte	0						PSET		
	1		PLC Enable	White Flash	Pause				Tool Enable
	2-11	Sequence Number							
	12-31	Serial Number							

Byte	Bit	Name	Function
0	0-3	PSET	Set the active parameter set of 1-8. If 0 the active parameter set is left unchanged.
	4-7	Not used	
1	0	Tool Enable	If PLEC Enable is 0 this input is ignored. If PLC Enable is 1 this bit can be used to enable or disable the tool.
	1-3	Not used	
	4	Pause	Setting Pause to 1 cause the light stack to strobe. Setting it to 0 put the light stack back into its normal operation.
	5	White Flash	Setting White Flash to 1 cause the light stack to flash the white light. Setting it to 0 put the light stack back into its normal operation.
	6	PLC Enable	Setting PLC Enable to 1 allows the Tool Enable bit. Setting it to 0 disables the Tool Enable function.
	7	Not used	
2-11	0-7	Sequence Number	10 character Sequence Number.
12-31	0-7	Serial Number	20 character Serial Number.

## 17 Error Proofing

### 17.1 Barcode Reader

The max length of a barcode is 20 characters if it is longer the leading characters will be lost and the last 20 will be used. Since barcode readers send their characters in burst there is no need to program in a length. The software just waits for the reader to stop sending. Once the barcode is read the results are stored as the VIN.

### 17.2 VIN Pattern Matching

All new VINs from barcode readers, Profibus, DeviceNET, or protocols are checked against for a VIN match against each PSET (starting from #1 and through #8). If a match is found the PSET is changed. In order to qualify as a match the received barcode must be at least as long as the match string. The match string can contain “don’t care” characters (‘.’) as a wild card. In the example below a barcode of “Abc123” selects PSET #1, “abc567” selects PSET #2, “def” selects PSET #4, “ABc” selects PSET #5, and “AB” does nothing.

VIN Match	Process Number	Pset	Count	Action	Next Pset
<u>Abc</u>	1	1	2	Disable Tool - Hold Count & Output Batch Complete	
<u>abc</u>	2	2	3	Disable Tool - Hold Count & Output Batch Complete	
DEF	3	3	4	Disable Tool - Hold Count & Output Batch Complete	
def	4	4			
..c	5	5			
	6	6			
	7	7			
	8	8			