

2004 3/4" AIR IMPACT WRENCH

EXPLODED VIEW

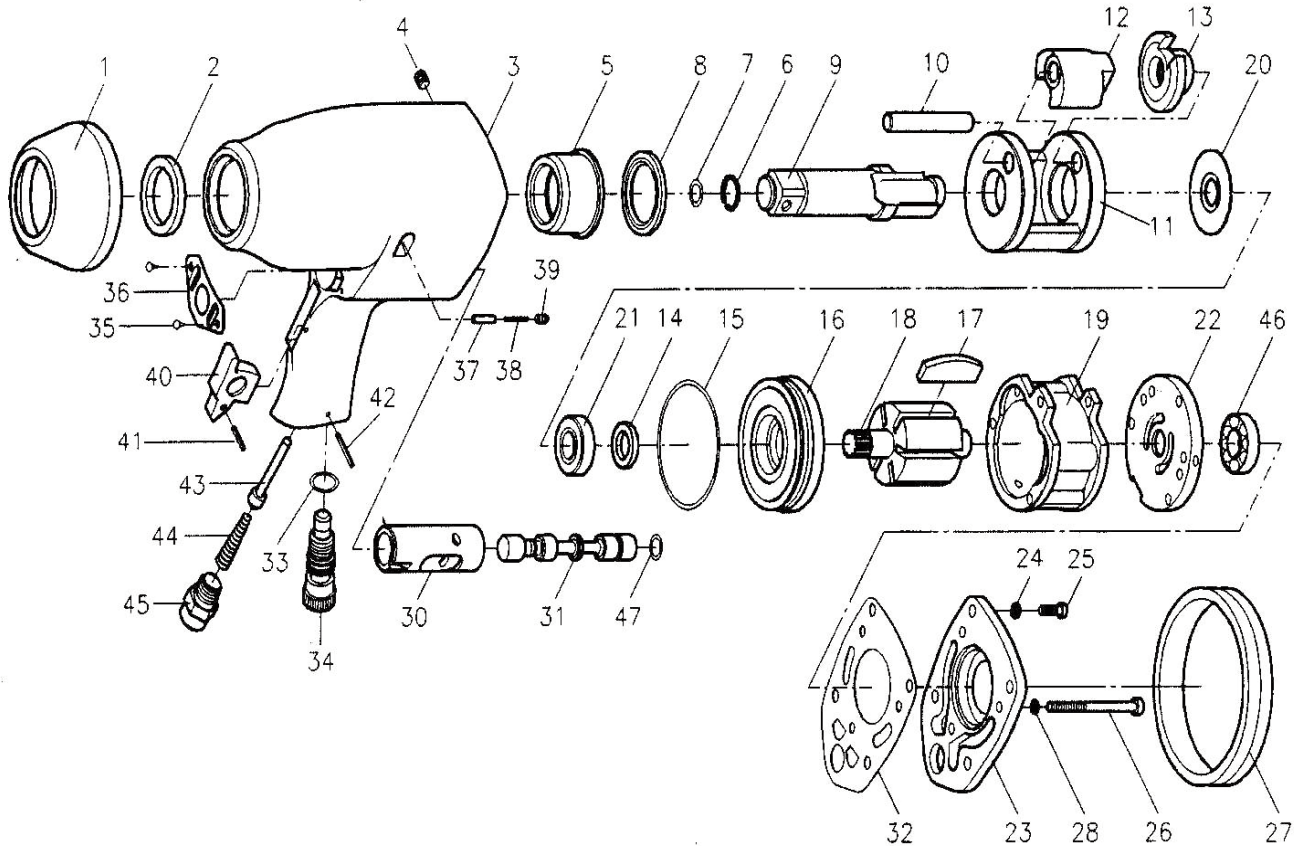

PARTS LIST — FOR REFERENCE ONLY

Index Number	Part Number	Description	Qty.	Index Number	Part Number	Description	Qty.
1	280-031	Protecting	1	25	00-0119	Cap Screw	4
2	00-4205	Oil Seal	1	26	00-0110	Cap Screw	3
3	280-001	Motor Housing	1	27	280-032	Protecting Rubber	1
4	00-0614	Screw	1	28	00-1802	Spring Washer	3
5	280-010	Anvil Bushing	1	30	280-019	Valve Sleeve	1
6	280-280	Anvil Collar	1	31	280-020	Reverse Valve	1
7	00-4118	O-Ring	1	32	280-030	Rear Gasket	1
8	280-029	Spacer	1	33	00-4106	O-Ring	1
9	280-011A6	Anvil	1	34	280-023-B	Regulator	1
	280-011B6	6" Anvil	1	35	00-0802	Screw	1
10	280-016	Hammer Pin	1	36	280-026A	Exhaust Deflector	2
11	280-012	Hammer Cage	1		280-026B	Exhaust Deflector	1
12	280-015	Hammer	1	37	280-024	Pin	1
13	280-013	Cam	1	38	280-028	Spring	1
14	00-4206	Oil Seal	1	39	00-0609	Screw	1
15	00-4108	O-Ring	1	40	280-021A	Trigger	1
16	280-005	Front End Plate	1	41	00-3301	Spring Pin	1
17	280-008	Rotor Blade	6	42	00-3305	Spring Pin	1
18	280-007-B	Rotor	1	43	280-022	Valve Stem	1
19	280-006	Cylinder	1	44	280-025	Spring	1
20	280-033	Rear Washer	1	45	250-024A	Air Inlet (1/4"PF)	1
21	00-2312	Ball Bearing	1		250-024B	Air Inlet (1/4"PT)	1
22	280-009	Rear End Plate	1		250-024C	Air Inlet (1/4"NPT)	1
23	280-003	Rear Cover	1	46	00-2313	Ball Bearing	1
24	00-1803	Spring Washer	4	47	00-4114	O-Ring	1

FOOTNOTES



10000 SE Pine Street
Portland, OR 97216
503-254-6600
FAX 503-255-2615

When ordering spare parts, please specify
tool type, part number and description.