

2256/2257 IMPACT WRENCH 1/2"

EXPLODED VIEW

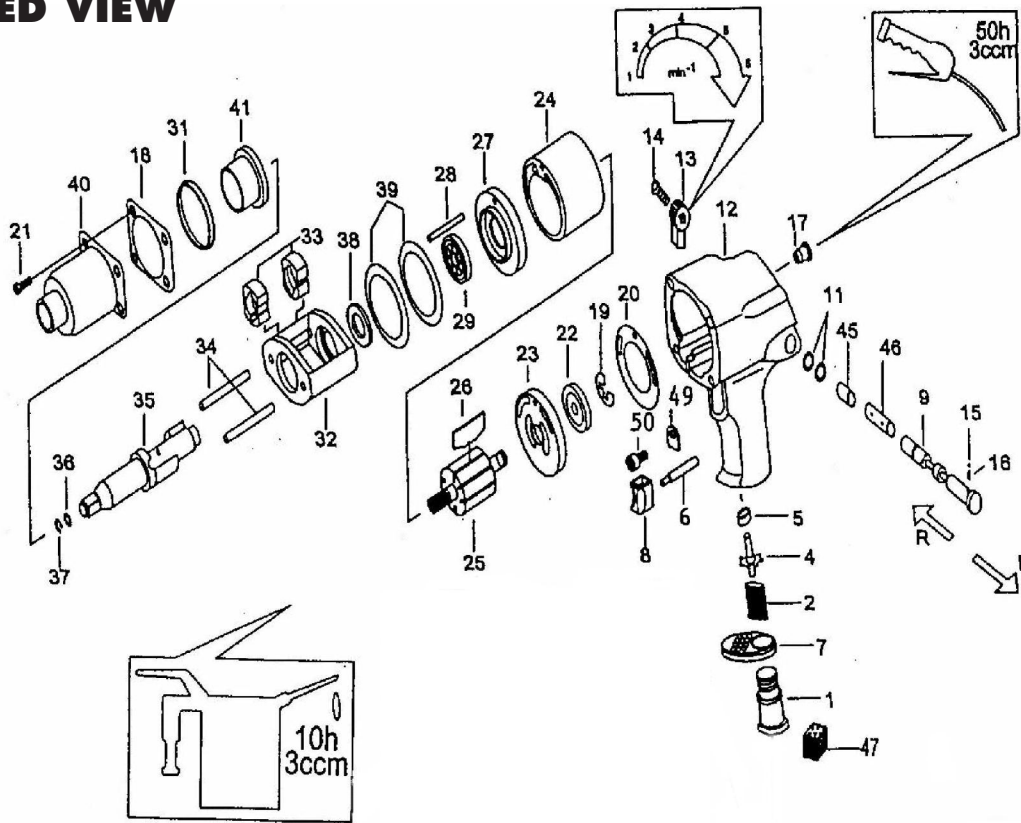

PARTS LIST — FOR REFERENCE ONLY

Index Number	Part Number	Description	Qty	Index Number	Part Number	Description	Qty.
1	RC2256B-01	Air Inlet	1	31	RC2256B-31	Hammer Case Spacer	1
2	RC2256B-02TK	Throttle Valve Spring	1	32	RC2256B-32	Hammer Frame	1
4	RC2256B-04	Flow Regulator	1	33	RC2256B-33RK	Hammer	2
5	RC2256B-05TK	Throttle Valve Seat	1	34	RC2256B-34RK	Hammer Pin	2
6	RC2256B-06	Valve Pin	1	35A	RC2256B-35ARK	Standard Anvil incl. 36, 37	1
7	RC2256B-07	Exhaust Silencer	1	35B	RC2257B-35BRK	2" Extension Anvil incl. 36, 37 *	1
8	RC2256B-08	Trigger	1	36	RC2256B-36RK	O-Ring	1
9	RC2256B-09	Reverse Valve	1	37	RC2256B-37RK	Socket Retainer	1
11	RC2256B-11TK	O-Ring	2	38	RC2256B-38	Rear Washer	1
12	RC2256B-12	Motor Housing incl. 11,45,46	1	39	RC2256B-39	Motor Clamp Washer	2
13	RC2256B-13	Reverse Valve Knob	1	40	RC2256B-40	Hammer Case	1
14	RC2256B-14	Screw	1	41	RC2256B-41	Hammer Case Bushing	1
15	RC2256B-15TK	Reverse Valve Detend Ball	1	42	RC2256B-42	Exhaust Hose	1
16	RC2256B-16TK	Reverse Valve Detent Spring	1	43	RC2256B-43	O-Ring/Acc.:852200	1
17	RC2256B-17	Grease Fitting	1	45	RC2256B-45	Bushing	1
18	RC2256B-18TK	Hammer Case Gasket	1	46	RC2256B-46	Reverse Valve Bushing	1
19	RC2256B-19	Rear Rotor Bearing Retaining	1	47	RC2256B-47TK	Muffler	1
20	RC2256B-20TK	End Plate Gasket	1	49	RC2256B-49	End Cap	1
21	RC2256B-21	Screw	4	50	RC2256B-50	End Cap Screw	1
22	RC2256B-22RK	Rear End Plate Bearing	1		RC2256B-RK	Repair Kit 22, 29, 33, 34, 35A, 35B, 36, 37	
23	RC2256B-23	Rear End Plate	1		RC2256B-TK	Tune Up kit 2, 5, 11, 15, 16, 18, 20, 26, 47	
24	RC2256B-24	Cylinder	1				
25	RC2256B-25	Rotor	1				
26	RC2256B-26TK	Vane Packet	6				
27	RC2256B-27	Front End Plate	1				
28	RC2256B-28	Cylinder Dowel	1				
29	RC2256B-29RK	Front Rotor Bearing	1				

FOOTNOTES

* 2257

Tune Up Kit: includes all parts having "TK" at the end.
Repair Kit: includes all parts having "TK" and "RK" at the end.



1000 SE Pine Street
Portland, OR 97216
503-254-6600
FAX 503-255-2615

When ordering spare parts, please specify tool type, part number and description.