

# 6017 DUAL PISTON SANDER / FILER

## EXPLODED VIEW

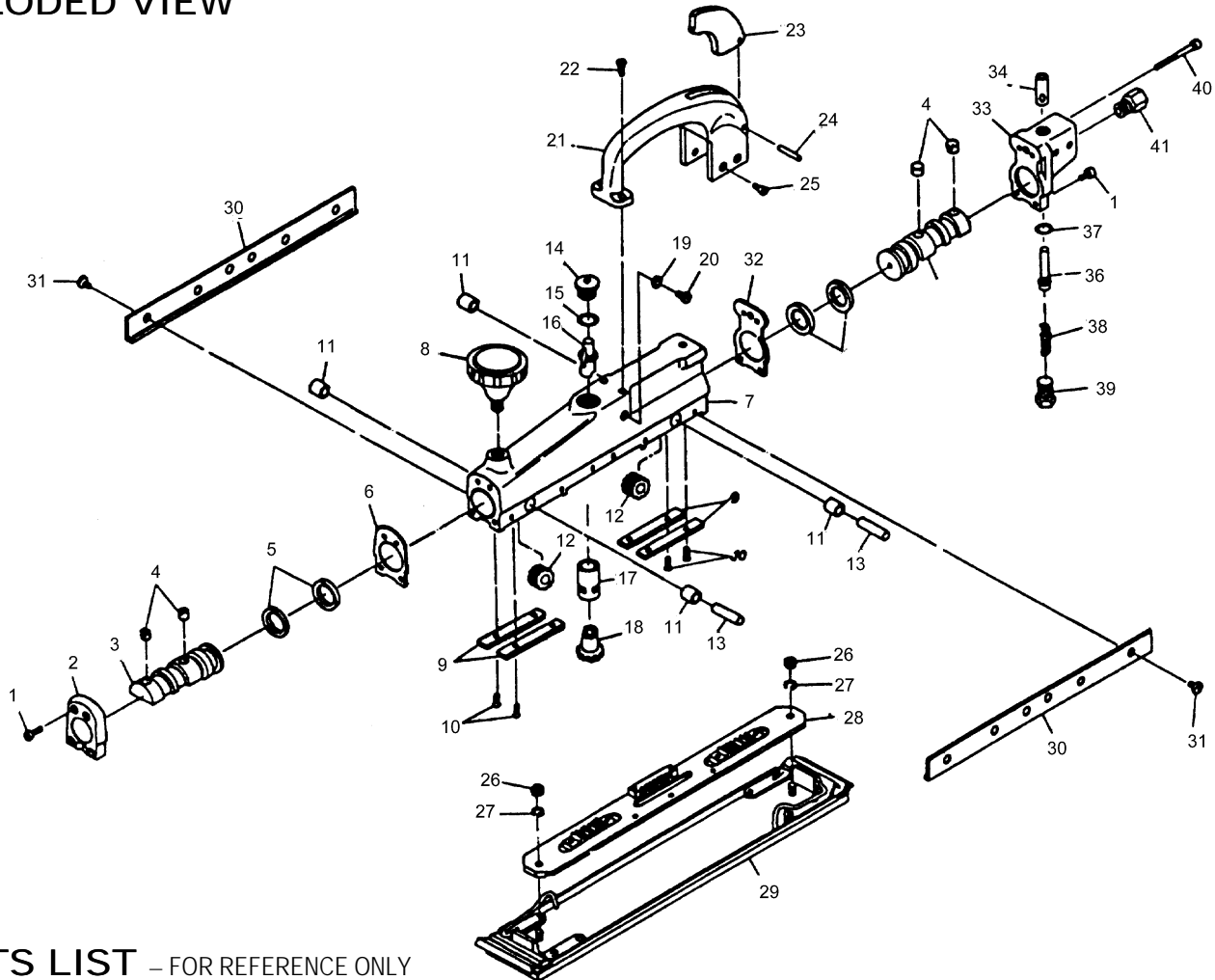

## PARTS LIST – FOR REFERENCE ONLY

Index Number	Part Number	Description	Qty.	Index Number	Part Number	Description	Qty.	Index Number	Part Number	Description	Qty.
1	109001	Socket Hd. Scr.	6	14	109014	Plunger	1	28	109028	Carrier	1
2	109002	Front Cap	1	15	109015	O ring	1*	29	109029	Pad Assembly	1
3	109003	Piston	2	16	109016	Adi Shaft	1	30	109030	Side Strap	2
4	109004	Plug	4*	17	109017	Actuator Valve	1	31	109031	Ph. Rd. Hd. Scr.	12
5	109005	Piston Pin	4*	18	109018	Actuator Gear	1	32	109032	Rear Gasket	1*
6	109006	Front Gasket	1*	19	109019	O ring	1	33	109033	Rear Cap	1
7	109007	Body	1	20	109020	Flat HD.	1	34	109034	Bushing	1
8	109008	Knob	1	21	109021	Handle	1	36	109036	Valve Pin	1
9	109009	Wear Plate	4*	22	109022	Ph. Rd. Hd Scr.	2	37	109037	O ring	1
10	109010	Socket Hd. Scr.	8	23	109023	Trigger	1	38	109038	Valve Spring	1
11	109011	Bushing	4	24	109024	Roll Pin	1	39	109039	Valve Plug	1
11A	109011A	Bearing	4	25	109025	Ph. Rd. Hd. Scr.	4	40	109040	Socket Fid. Scr.	2
12	109012	Gear	2	26	109026	Flex. Nut	2	41	109041	Hose adapter.	1
13	109013	Gear Shaft	2	27	109027	Washer	2				

### TECHNICAL DATA

	Max Air Pressure	Recommended Air Hose Size	BPM Free Speed	Max Air Flow CFM	Weight (lbs.)
6017	90 psi	3/8"	3,300	9	6.87

### FOOTNOTES

\* Parts Available in Repair Kit 6017-RK\*



When ordering spare parts, please specify tool type, part number and description

10000 SE PINE, PORTLAND, OR 97216  
503-254-1749 FAX 503-256-4026

REVISED 7/99