

UAT-150 SERIES OIL-PULSE WRENCHES

EXPLODED VIEW

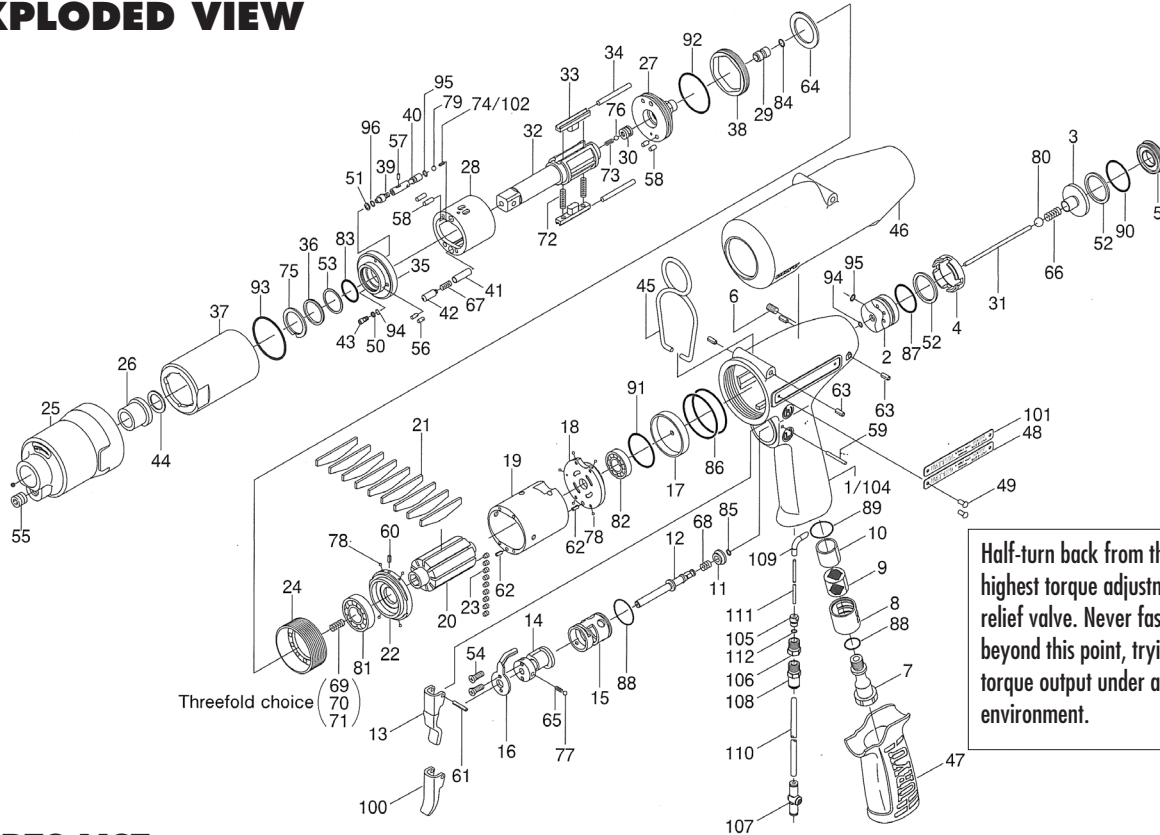

Half-turn back from thread end is the highest torque adjustment point of relief valve. Never fasten relief valve beyond this point, trying to turn up torque output under a low air pressure environment.

PARTS LIST — FOR REFERENCE ONLY

Index Number	Part Number	Description	Qty.	Index Number	Part Number	Description	Qty.	Index Number	Part Number	Description	Qty.
1	130-025-6	Handle	1	41	17F-274-7	Pressure Valve Spring Cover	1	81	982-905-0	Ball Bearing (6904)	1 ●
2	130-253-2	Shut-off Valve Bushing	1	42	18G-276-4	Pressure Valve Body	1	82	982-951-0	Ball Bearing (16003)	1 ●
3	130-254-2	Shut-off Valve	1	43	194-742-3	Oil Plug	1	83	990-170-0	O-Ring (ARP568-120) (NTN)	1
4	130-684-2	Cushion Spacer	1	44	130-327-5	Anvil Front Spacer	1	84	990-305-0	O-Ring (ARP568-003) (KS)	1 ■
5	130-019-2	Valve Cover	1	45	174-790-0	Suspension Ring	1	85	990-306-0	O-Ring (ARP568-004) (H)	1
6	150-108-5	Valve Plug	1	46	130-840-4	Casing Cover	1	86	990-316-0	O-Ring (ARP568-035)	2 ●
7	130-091-2	Air Inlet Bushing	1	47	17F-842-7	Handle Cover	1	87	990-332-0	O-Ring (JW1530-22)	1
8	130-780-2	Exhaust Stack	1	48	18G-924-4	Name Plate	1	88	990-916-0	O-Ring (SNS-18)	2
9	130-042-2	Silencer	1	49	930-205-0	Drive Rivet (No. 0 x 2.6)	2	89	990-921-0	O-Ring (SNS-22.4)	1
10	130-835-2	Filter (K100)	1 ●	50	944-003-0	Supporting Ring (3 x 5 x 1)	1 ■	90	990-922-0	O-Ring (SNS-28)	1
11	130-100-2	Valve	1	51	944-205-0	Supporting Ring (5.1 x 7 x 1)	1 ■	91	990-929-0	O-Ring (SNS-36)	1
12	130-104-2	Valve Rod	1	52	944-223-0	Supporting Ring (22 x 29.5 x 1.5)	2	92	990-937-0	O-Ring (SNS-46)	1
13	130-107-2	Valve Lever	1	53	944-225-0	Supporting Ring (25.2 x 29.4 x 1.5)	1 ■	93	990-938-0	O-Ring (SNS-48)	1 ■
14	130-210-2	Reverse Valve	1	54	948-423-0	Allen Flush Head Screw (M3 x 6)	2	94	990-970-0	O-Ring (SNS-2) (NOK)	1
15	130-211-2	Reverse Valve Bushing	1	55	966-099-0	Allen Head Plug (NPT 1/16)	2	95	990-971-0	O-Ring (SNS-3) (NOK)	1 ■
16	130-212-2	Reverse Lever	1	56	969-450-0	Pin (G) (3 x 8)	2	96	990-972-0	O-Ring (SNS-4) (NOK)	1 ■
17	130-291-4	Rear Plate Spacer	1	57	970-093-0	Pin (H) (2 x 6)	1	FOR UAT-150L			
18	130-285-4	Rear Plate	1	58	970-206-0	Pin (H) (3 x 8)	4	101	18G-924-5	Name Plate for UAT-150L	1
19	130-286-4	Cylinder	1	59	971-126-0	Pin (2 x 2.6)	1	102	977-062-0	Cone Spring (3.9 x 4.9 x 11.6)	1
20	130-287-4	Rotor	1	60	973-066-0	Roll Pin (2.5 x 6)	1	FOR T-M TYPE			
21	130-288-2	Blade	9 ●	61	973-120-0	Roll Pin (3 x 20)	1	104	852-574-1	Handle	1
22	114-289-8	Front Plate	1	62	973-212-0	Roll Pin (4 x 12)	2	105	851-967-1	Plug	1
23	130-064-4	Plug	9	63	973-308-0	Roll Pin (5 x 8)	4	106	851-955-1	Connecting Screw	1
24	130-036-4	Hammer Casing Connector	1	64	975-812-0	Adjusting Spacer (30 x 17 x T)	1	107	909-442-0	Quick Exhaust (AQ240F-04-00)	1
25	130-439-4	Front Casing	1	65	976-006-0	Spring (3 x 5)	1	108	933-281-0	One-Touch Connector (KQ2H04-M5N)	1
26	163-328-4	Anvil Bushing	1	66	976-963-0	Spring (4.4 x 14.5)	1	109	935-240-0	Nylon Tube (18NY)	1
27	18G-901-4	Rear Liner Plate	1	67	976-498-0	Spring (4.3 x 22) n-14.5	1 ■	110	935-350-0	Polyurethane Hose (F-1504)	1
28	18G-902-4	Liner	1	68	976-643-0	Spring (7.5 x 9.7)	1	111	935-358-0	Polyurethane Hose (TU-0212)	1
29	145-546-6	Piston	1	69	976-662-0	Spring (3.3 x 18) (Standard) (Gold)	1	112	990-320-0	O-Ring (ARP568-003)	1
30	130-929-4	Check Valve Cover	1	70	976-857-0	Spring (3.3 x 17) (Weak) (Brown)	1	ACCESSORIES			
31	130-130-4	Operating Rod (2.1 x 77)	1	71	976-985-0	Spring (3.3 x 18) (Strong) (Silver)	1	97	940-114-0	Air Hose Nipple (NPT 1/4 x 3/8)	1
32	130-319-4	Anvil	1	72	976-795-0	Spring (4.3 x 40.5) WPC	2	98	939-109-0	Allen Wrench (2 mm)	1
33	130-440-4	Driving Blade	2	73	976-884-0	Spring (2.4 x 5.4)	1 ■	99	939-105-0	Allen Wrench (4 mm)	1
34	130-974-2	Roller (3 x 40)	2	74	977-061-0	Cone Spring (3.9 x 5 x 11.2)	1 ■	103	909-449-0	Speed Controller (AS1001F-04 for TM-Type)	1
35	17M-904-0	Front Liner Plate	1	75	979-207-0	Snap Ring (30)	1	Optional Accessory			
36	163-807-5	Spacer	1	76	981-001-0	Ball (3/32)	1	100	130-107-4	Valve Lever (Short)	1
37	130-905-4	Liner Casing	1	77	981-002-0	Ball (1/8)	1	FOOTNOTES			
38	130-906-4	Liner Casing Cover	1	78	981-045-0	Ball (1.5)	9	● = Items in Repair Kit UAT-150-RK			
39	175-907-9	Relief Valve Spindle	1	79	981-155-0	Ball (3.5)	1	■ = Items in Pulse Repair Kit UAT-150-PRK			
40	18G-970-4	Relief Valve	1	80	981-245-0	Ball (4.5)	1				



10000 SE PINE
PORTLAND, OR 97216
503-254-6600
FAX 503-255-2615

When ordering spare parts, please specify tool type, part number, and description.

FOOTNOTES
● = Items in Repair Kit UAT-150-RK
■ = Items in Pulse Repair Kit UAT-150-PRK