

# UDP-A80MC & (TL) SERIES OIL PULSE WRENCHES

## EXPLODED VIEW

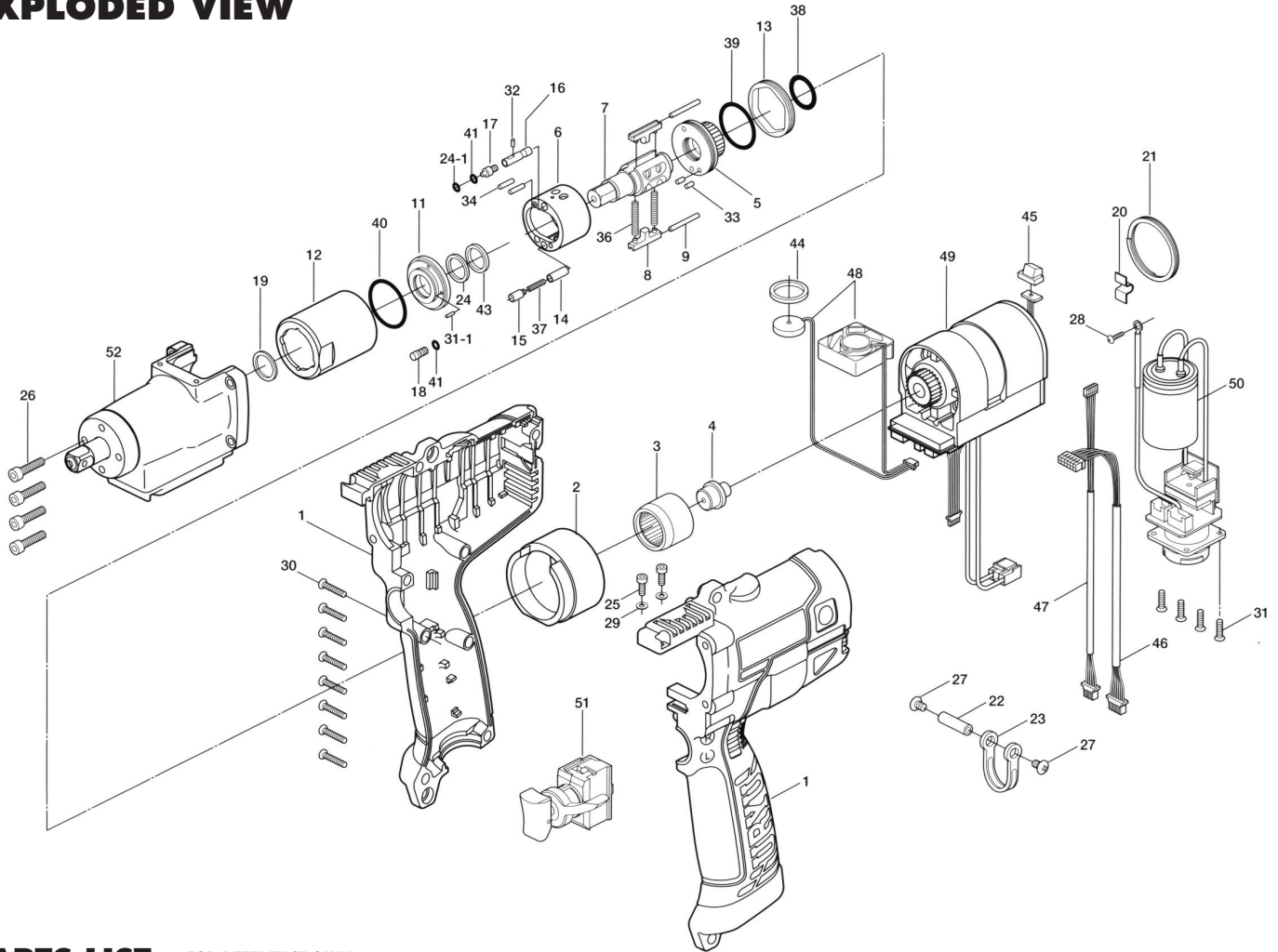

## PARTS LIST — FOR REFERENCE ONLY

Index Number	Part Number	Description	Qty.	Index Number	Part Number	Description	Qty.	Index Number	Part Number	Description	Qty.
1	073-025-6	Handle Set	1	24-1	944-203-0	Back-up Ring (3.1 x 5 x 1)	1 ●	47	910-817-0	Communication Cable	1
2	073-255-6	Regulator Barrel	1	25	945-000-0	Allen Head Bolt (M3 x 8)	2	48	910-487-0	Fan and Buzzer Assembly	1
3	073-465-4	Internal Gear	1	26	945-018-0	Allen Head Bolt (M4 x 18)	4	49	910-578-0	Motor Assembly	1
4	073-567-4	Bushing	1	27	945-941-0	Hexagon Head Bolt (M4 x 5)	2	50	910-993-0	Power Board Assembly	1
5	073-901-6	Rear Liner Plate	1	28	948-001-0	Round Head Screw (M2.6 x 8)	1	51	098-174-4	Switch Assembly	1
6	18E-902-3	Liner	1	29	961-008-0	Flat Washer (3)	2	52	851-668-1	Sensor Cable Assembly WD06S	1
7	851-982-1	Anvil	1	30	963-253-0	Tapping Screw (3 x 16)	8	<b>PARTS FOR UDP-A80MC(TL) NEEDED IN PLACE OF #1, #31, AND #50</b>			
8	147-440-6	Driving Blade	2	31	963-252-0	Tapping Screw (3 x 10)	4	54	073-025-5	Handle Set	1
9	147-974-6	Roller (2.5 x 28)	2	31-1	969-449-0	Pin (G) (3 x 6)	1	55	073-012-4	Handle Cover	1
11	18E-904-3	Front Liner Plate	1	32	970-013-0	Pin (H) (1.5 x 4)	1	56	910-969-0	Power Board Assembly	1
12	17E-905-0	Liner Casing	1	33	970-202-0	Pin (H) (3 x 4.5)	2	57	957-006-0	Cross Head Screw (M3 x 6)	4
13	147-906-6	Liner Casing Cover	1	34	970-204-0	Pin (H) (3 x 6)	2	58	979-320-0	Inner Snap Ring (IRTW20)	1
14	18F-274-2	Spring Holder	1	36	976-788-0	Spring (3.5 x 25) WPC	2 ●	59	990-919-0	O-Ring (SNS-22)	1
15	080-276-6	Adjusting Valve	1	37	976-755-0	Spring (3 x 13.3)	1 ●	<b>ACCESSORIES</b>			
16	17E-970-0	Relief Valve	1	38	990-016-0	O-Ring (P16)	1	60	910-517-0	Joint Cable Assembly UDP 5M	1
17	174-907-2	Relief Valve Spindle	1	39	990-923-0	O-Ring (SNS-26)	1 ●	61	910-518-0	Joint Cable Assembly UDP 10M	1
18	194-742-0	Oil Plug	1	40	990-334-0	O-Ring (JW1530-24)	1 ●				
19	145-327-7	Anvil Front Spacer	1	41	990-900-0	O-Ring (SNS-2)	2 ●				
20	073-792-4	Suspension Bushing	1	43	991-030-0	X-Ring	1 ●				
21	004-790-2	Suspension Ring	1	44	993-102-0	Rubber Sponge	1				
22	136-791-7	Suspension Bail Base	1	45	910-580-0	Front Cover	1				
23	136-790-7	Suspension Bail	1	46	910-971-0	Sensor Cable	1				
24	944-213-0	Back-up Ring (12 x 16 x 1.0)	1 ●								



10000 SE PINE  
PORTLAND, OR 97216  
503-254-6600  
FAX 503-255-2615

When ordering spare parts, please specify tool type, part number, and description.

### FOOTNOTES

● = Items in Pulse Repair Kit UDP-A80MC-PRK