

COMMENTS	ITEM NO.	PART NUMBER	QTY.	DESCRIPTION
	1	26212	1	MOTOR ASM., 7000 SERIES
	2	26227	1	O-RING, MOTOR HOUSING
	3	25574	5	STANDOFF M-F, 4-40x1/4, 3/16 HEX, SS
	4	27727	1	TID BOARD, POPULATED W/AMP
	5	25573	5	SCREW PHP 4-40 X 3/16 18-8 SS
	6	SEE CHART	1	GEAR BOX ASM.
	7	26299	1	O-RING, PINION
	8	29279	6	SCREW, BHSC, TORX, 10-32 x 3/8, STEEL
	9	25212	1	SWITCH SUB-ASSEMBLY
NOT SHOWN	10	25788	1	CABLE, TRIGGER, GEN 4 PISTOL
	11	26276	1	"D" / "J" HANDLE
	12	25745	4	SCREW, BHSC 4-40 STEEL, BLACK OXIDE
	13	26226	1	O-RING, LED COVER
	14	20534	1	3000 SERIAL/MODEL LABEL
	15	26223	1	LED COVER
	16	26288	1	TOOL CONNECTOR ASM., PISTOL
	17	SEE CHART	1	GEAR CASE COVER
	18	26319	3	SCREW, BHSC 6-32 X .188, 18-8 SS
	19	26297	1	TRAY, WIRE, "D" & LEVER HANDLE
	20	26206	6	SCREW, BHSC 10-32 X .375, STEEL
	21	26278	1	END CAP, "D" HANDLE
	22	26334	4	SCREW, SHC 10-32 X 1.50, STEEL, BLACK OXIDE
	23	26897	1	CHOOSE REACTION BAR
	24	26243	1	RETAINING RING, SPIRAL, Ø2.864 X Ø2.464 X .078
	25	28211	1	(4) LINE MALE/FEMALE JUMPER ASM.
NOT SHOWN	26	27464	A/R	TWISTED WAXED LINEN TWINE
	27	29336	1	TID BOARD WIRE INSULATOR
	28	29337	3	STANDOFF, M-F, 4-40 X 1/8, SS

TOOL MODEL	GEAR BOX ASM.	GEAR CASE COVER
AED4A771200B	28110	26298
AED4A773000B	28111	26295

◆ ASSEMBLY INSTRUCTIONS
 ◊ SUB-ASSEMBLY

- 1) GEARS & SPLINES: LUBRICATE WITH DOW CORNING MOLYKOTE BR2 PLUS GREASE.
- 2) BEARINGS: LUBRICATE WITH CHEVRON SR1 GREASE
- 3) O-RINGS: LUBRICATE WITH O-RING LUBE



DOCUMENT CONTROL
 PRINTED COPIES OF THIS DOCUMENT ARE CONSIDERED TO BE UNCONTROLLED DOCUMENTS. HOLDERS ARE RESPONSIBLE FOR VERIFYING THE CURRENT REVISION LEVEL WITH PURCHASING OR ENGINEERING PRIOR TO USE OR FABRICATION. THE CONTROLLED VERSION OF THIS DOCUMENT IS ELECTRONICALLY MAINTAINED.

PROPRIETARY AND CONFIDENTIAL
 THIS DRAWING CONTAINS INFORMATION STRICTLY CONFIDENTIAL TO ACRADYNE/AIMCO. IN THE ABSENCE OF EXPRESSED WRITTEN PERMISSION, ACRADYNE/AIMCO HAS LOANED THIS COPY WITH THE MUTUAL UNDERSTANDING THAT (A) IT WILL NOT BE USED FOR ANY PURPOSE OTHER THAN FOR THAT IN WHICH IT WAS PROVIDED, (B) THE DATA CONTAINED HEREIN WILL NOT BE DISCLOSED TO OTHERS, (C) IT WILL NOT BE REPRODUCED, AND (D) IT WILL BE RETURNED TO ACRADYNE/AIMCO IMMEDIATELY UPON DEMAND.

REVISION LEVEL	REVISION RELEASE DATE	DESCRIPTION OF CHANGES MADE TO PART	ECN #	AUTHOR/ APPROVAL
REVISION BLOCK				

UNLESS OTHERWISE SPECIFIED, DIMENSIONS ARE IN INCHES
 DIMENSIONS AND TOLERANCING PER ANSI Y14.5
 SURFACE ROUGHNESS PER ANSI Y14.36

BLOCK TOLERANCING PER DECIMAL:
 .X = ±.030 .XX = ±.010 .XXX = ±.005 .XXXX = ±.0005
 ANGLE = ±0° 30'

REMOVE BURRS AND SHARP EDGES: R.015 MAX
 MACHINE SURFACE FINISH: 125 RMS OR BETTER

DRAWINGS AND TECHNICAL DOCUMENTS CONTROLLED BY:
ACRADYNE MECHANICAL ENGINEERING

"D" HANDLE NUTRUNNER 7000 SERIES		
SIZE	PART / DRAWING NUMBER	REVISION
D	AED4A77	B A
SCALE 1:2	DO NOT SCALE DRAWING	SHEET 1 OF 2

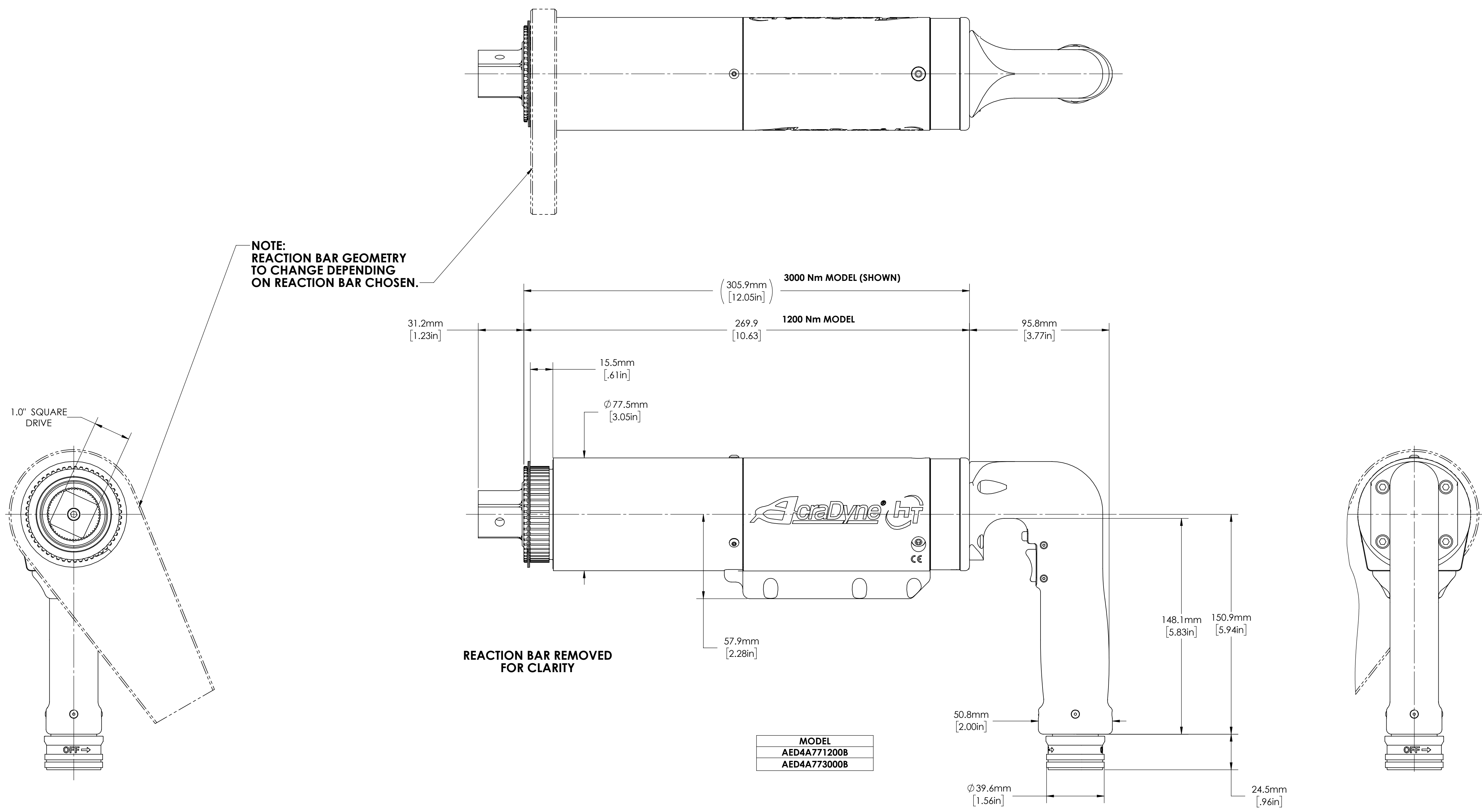

NOTE:
REACTION BAR GEOMETRY
TO CHANGE DEPENDING
ON REACTION BAR CHOSEN.

3000 Nm MODEL (SHOWN) 305.9mm [12.05in]
1200 Nm MODEL 269.9 [10.63]

1.0" SQUARE DRIVE

REACTION BAR REMOVED FOR CLARITY

MODEL
AED4A771200B
AED4A773000B

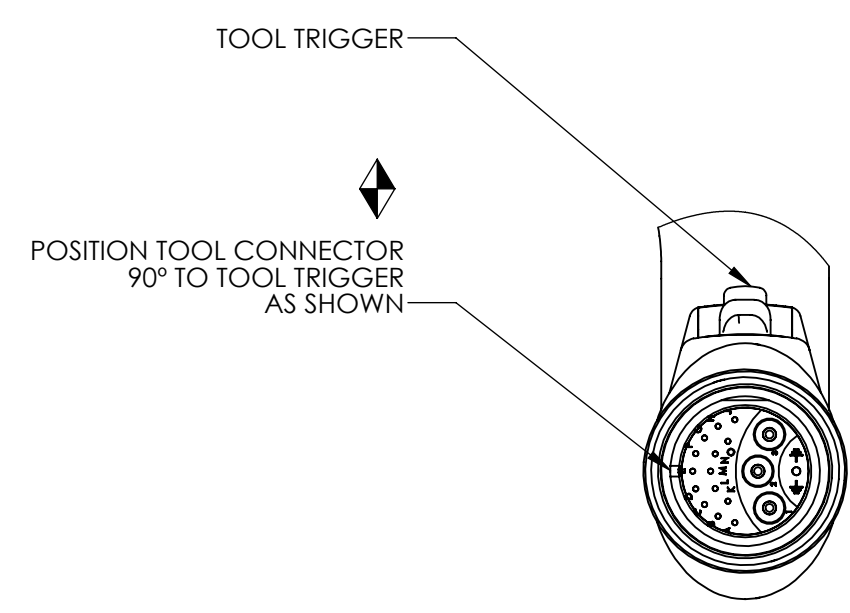

DOCUMENT CONTROL
PRINTED COPIES OF THIS DOCUMENT ARE CONSIDERED TO BE UNCONTROLLED DOCUMENTS. HOLDERS ARE RESPONSIBLE FOR VERIFYING THE CURRENT REVISION LEVEL WITH PURCHASING OR ENGINEERING PRIOR TO USE OR FABRICATION. THE CONTROLLED VERSION OF THIS DOCUMENT IS ELECTRONICALLY MAINTAINED.

PROPRIETARY AND CONFIDENTIAL
THIS DRAWING CONTAINS INFORMATION STRICTLY CONFIDENTIAL TO ACRADYNE/AIMCO. IN THE ABSENCE OF EXPRESSED WRITTEN PERMISSION, ACRADYNE/AIMCO HAS LOANED THIS COPY WITH THE MUTUAL UNDERSTANDING THAT (A) IT WILL NOT BE USED FOR ANY PURPOSE OTHER THAN FOR THAT IN WHICH IT WAS PROVIDED, (B) THE DATA CONTAINED HEREIN WILL NOT BE DISCLOSED TO OTHERS, (C) IT WILL NOT BE REPRODUCED, AND (D) IT WILL BE RETURNED TO ACRADYNE/AIMCO IMMEDIATELY UPON DEMAND.

REVISION LEVEL	REVISION RELEASE DATE	DESCRIPTION OF CHANGES MADE TO PART	ECN #	AUTHOR/ APPROVAL
REVISION BLOCK				

UNLESS OTHERWISE SPECIFIED, DIMENSIONS ARE IN INCHES
DIMENSIONS AND TOLERANCING PER ANSI Y14.5
SURFACE ROUGHNESS PER ANSI Y14.36

BLOCK TOLERANCING PER DECIMAL:
X = ±.030 XX = ±.010 XXX = ±.005 XXXX = ±.0005
ANGLE = ±0° 30'

REMOVE BURRS AND SHARP EDGES: R.015 MAX
MACHINE SURFACE FINISH: 125 RMS OR BETTER

DRAWINGS AND TECHNICAL DOCUMENTS CONTROLLED BY:
ACRADYNE MECHANICAL ENGINEERING

"D" HANDLE NUTRUNNER 7000 SERIES		
SIZE	PART / DRAWING NUMBER	REVISION
D	AED4A77 B	A
SCALE: 2:3	DO NOT SCALE DRAWING	SHEET 2 OF 2