

NOTE:
REACTION BAR GEOMETRY
TO CHANGE DEPENDING
ON REACTION BAR CHOSEN

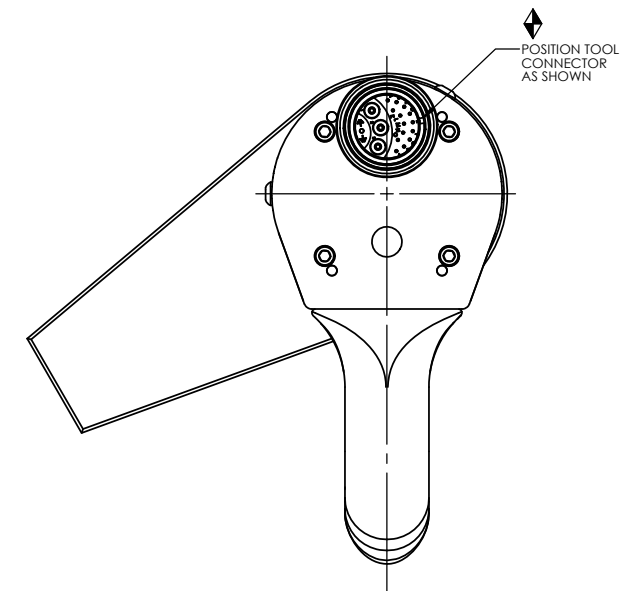

MODEL NO.	SQUARE DRIVE
AEJ4B884200B	1-1/2"
AEJ4B884200B1	1"
AEJ4W884650B	1-1/2"
AEJ4W884650B1	1"
AEJ4B885000B	1-1/2"
AEJ4B885000B1	1"
AEJ4W885000B	1-1/2"
AEJ4W885000B1	1"

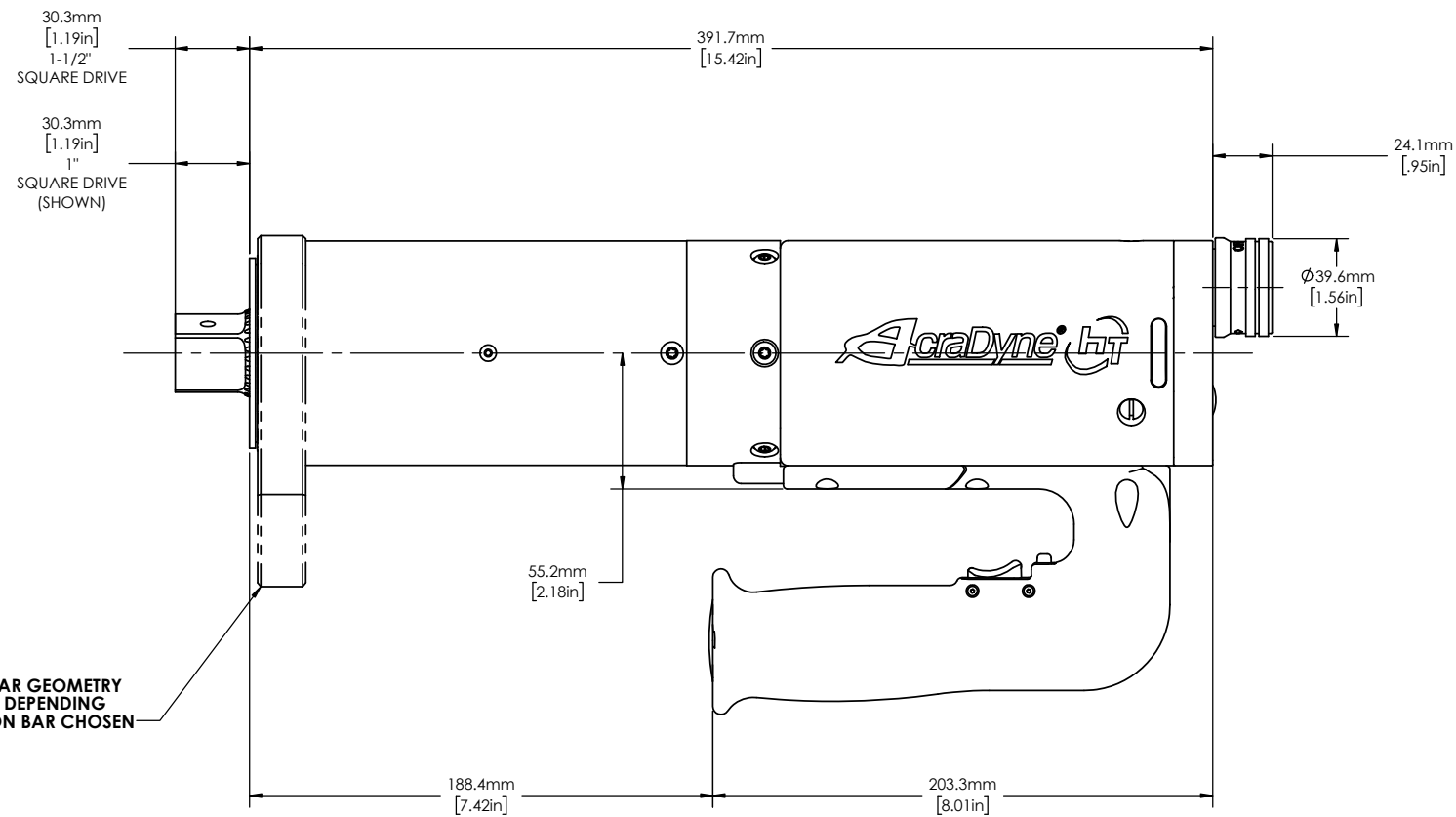

DOCUMENT CONTROL
PRINTED COPIES OF THIS DOCUMENT ARE CONSIDERED TO BE UNCONTROLLED DOCUMENTS. HOLDERS ARE RESPONSIBLE FOR VERIFYING THE CURRENT REVISION LEVEL WITH PURCHASING OR ENGINEERING PRIOR TO USE OR FABRICATION. THE CONTROLLED VERSION OF THIS DOCUMENT IS ELECTRONICALLY MAINTAINED.

PROPRIETARY AND CONFIDENTIAL
THIS DRAWING CONTAINS INFORMATION STRICTLY CONFIDENTIAL TO ACRADYNE/AIMCO. IN THE ABSENCE OF EXPRESSED WRITTEN PERMISSION, ACRADYNE/AIMCO HAS LOANED THIS COPY WITH THE MUTUAL UNDERSTANDING THAT (A) IT WILL NOT BE USED FOR ANY PURPOSE OTHER THAN FOR THAT IN WHICH IT WAS PROVIDED, (B) THE DATA CONTAINED HEREIN WILL NOT BE DISCLOSED TO OTHERS, (C) IT WILL NOT BE REPRODUCED, AND (D) IT WILL BE RETURNED TO ACRADYNE/AIMCO IMMEDIATELY UPON DEMAND.

REVISION LEVEL	REVISION RELEASE DATE	DESCRIPTION OF CHANGES MADE TO PART	ECN #	AUTHOR/ APPROVAL
REVISION BLOCK				

UNLESS OTHERWISE SPECIFIED, DIMENSIONS ARE IN INCHES
DIMENSIONS AND TOLERANCING PER ANSI Y14.5
SURFACE ROUGHNESS PER ANSI Y14.36

BLOCK TOLERANCING PER DECIMAL:
X = ±.030 XX = ±.010 XXX = ±.005 XXXX = ±.0005
ANGLE = ±0° 30'

REMOVE BURRS AND SHARP EDGES: R.015 MAX
MACHINE SURFACE FINISH: 125 RMS OR BETTER

DRAWINGS AND TECHNICAL DOCUMENTS CONTROLLED BY:
ACRADYNE MECHANICAL ENGINEERING

**"J" HANDLE NUTRUNNER
W/SLIP RING CLUTCH
8000 SERIES**

SIZE	PART / DRAWING NUMBER	REVISION
D	AEJ4 88	B E
SCALE: 1:8	DO NOT SCALE DRAWING	SHEET 2 OF 2