

COMMENTS	ITEM NO.	PART NUMBER	QTY.	DESCRIPTION
	1	26740	1	HOUSING, MOTOR/HANDLE
	2	25465	1	MOTOR ASM., PINNED
	3	25063	1	LED BOARD ASM.
	4	25075	2	SCREW, SHC 4-40X.375, STEEL, BLACK OXIDE
	5	25430	2	STAND-OFF, LED, 3000 SERIES
	6	27028	1	SCREW, SET 5-40 x .125, STEEL, CUP POINT
	7	26739	1	TRANSDUCER ADAPTER SUB-ASM
	8	27374	1	TRANSDUCER SUB-ASM., 40Nm
	9	25463	1	GEAR CASE SUB-ASM, 14T/14T
	10	21091	A/R	SHIM, PINION SHAFT, .002 --- 2000 SERIES
	11	21092	A/R	SHIM, PINION SHAFT, .005 --- 2000 SERIES
	12	21093	A/R	SHIM, PINION SHAFT, .010 --- 2000 SERIES
	13	27135	1	ANGLE HEAD ASM, 3/8 SQ.
	14	26102	1	TOOL CONNECTOR ASM., LEVER
	15	25745	5	SCREW, BHC 4-40X.188, STEEL, BLACK OXIDE
	16	25847	1	TID BOARD ASM.
	17	24934	2	SCREW, FHC 4-40 X .312, STEEL, BLACK OXIDE
	18	20132	1	THROTTLE SPRING
	19	26532	1	GEN 3 TRIGGER ASSY, CAST
	20	20061	2	SCREW, LEVER
	21	25072	1	O-RING, LED LIGHT RING COVER
	22	20534	1	3000 SERIAL/MODEL LABEL
	23	25058	1	LIGHT RING COVER, LED
	24	26084	1	HANDLE COVER, MFB
	25	24679	1	RETAINING RING
	26	24683	1	SPRING, REV BUTTON
	27	24706	1	REV BUTTON SUB-ASSEMBLY
	28	26083	1	HANDLE COVER
	29	24940	10	SCREW, FHSC 4-40 X .25 LG., STEEL, BLACK OXIDE
	30	22141	1	SAFETY LABEL

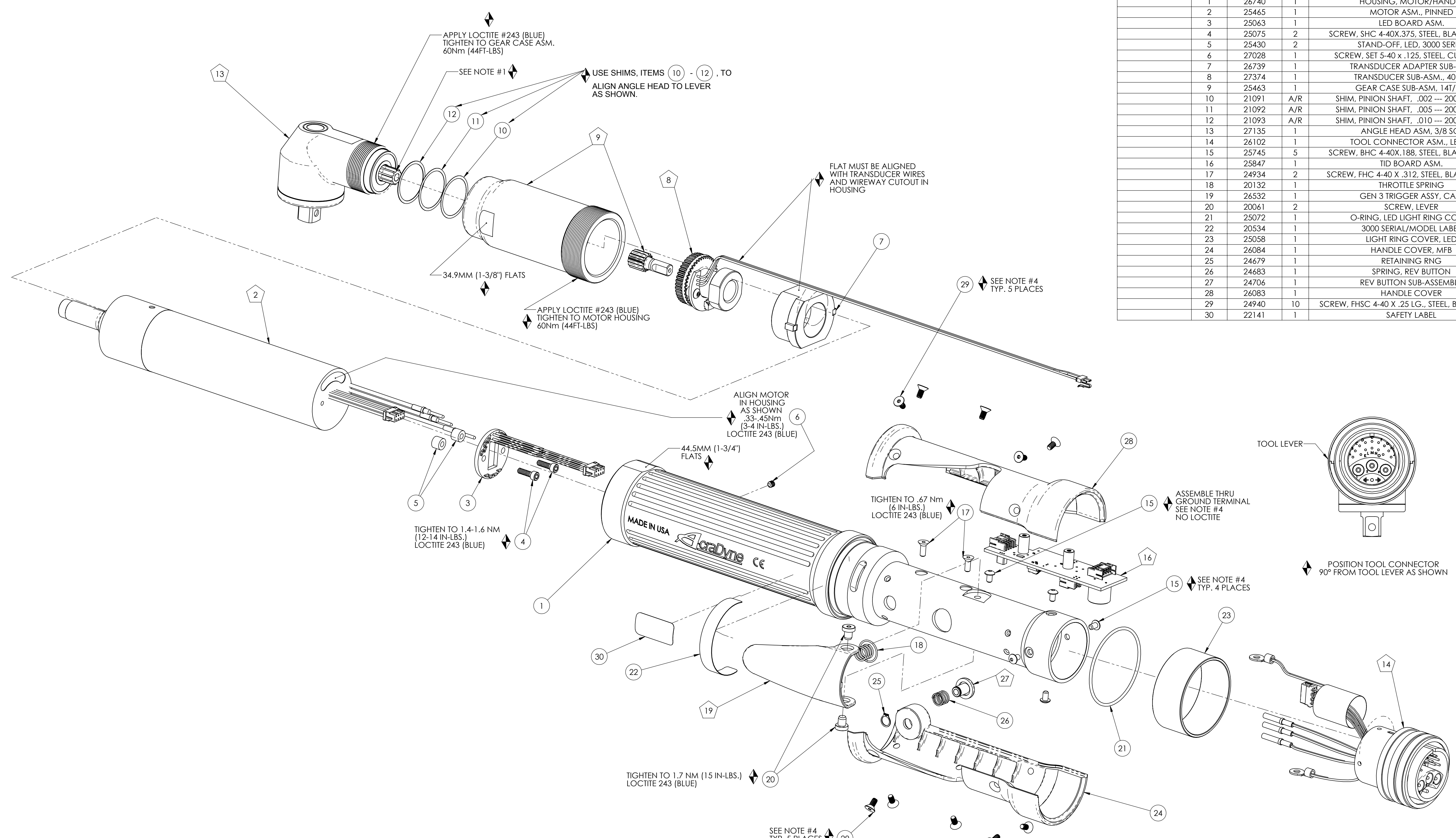

◆ ASSEMBLY INSTRUCTIONS
 ◊ SUB-ASSEMBLY

- GEARS & SPLINES: LUBRICATE WITH DOW CORNING MOLYKOTE BR2 PLUS GREASE.
- BEARINGS: LUBRICATE WITH CHEVRON SR1 GREASE
- O-RINGS: LUBRICATE WITH O-RING LUBE
- TIGHTEN TO 1.7 NM (15 IN-LBS.) LOCTITE 243 (BLUE)

REQUIRED TOOLING
LOCTITE 243 (BLUE)
1/16 HEX WRENCH
5/64 HEX WRENCH
3/32 HEX WRENCH
SNAP RING PLIERS - EXTERNAL TYPE
1-3/8" OPEN END CROWFOOT
1-3/4" OPEN END CROWFOOT

AIMCO
AcraDyne
 A Division of AIMCO
 10000 SE PINE STREET
 PORTLAND, OREGON 97216
 503.254.6600

DOCUMENT CONTROL
 PRINTED COPIES OF THIS DOCUMENT ARE CONSIDERED TO BE UNCONTROLLED DOCUMENTS. HOLDERS ARE RESPONSIBLE FOR VERIFYING THE CURRENT REVISION LEVEL WITH PURCHASING OR ENGINEERING PRIOR TO USE OR FABRICATION. THE CONTROLLED VERSION OF THIS DOCUMENT IS ELECTRONICALLY MAINTAINED.

PROPRIETARY AND CONFIDENTIAL
 THIS DRAWING CONTAINS INFORMATION STRICTLY CONFIDENTIAL TO ACRADYNE/AIMCO. IN THE ABSENCE OF EXPRESSED WRITTEN PERMISSION, ACRADYNE/AIMCO HAS LOANED THIS COPY WITH THE MUTUAL UNDERSTANDING THAT (A) IT WILL NOT BE USED FOR ANY PURPOSE OTHER THAN FOR THAT IN WHICH IT WAS PROVIDED, (B) THE DATA CONTAINED HEREIN WILL NOT BE DISCLOSED TO OTHERS, (C) IT WILL NOT BE REPRODUCED, AND (D) IT WILL BE RETURNED TO ACRADYNE/AIMCO IMMEDIATELY UPON DEMAND.

REVISION LEVEL	REVISION RELEASE DATE	DESCRIPTION OF CHANGES MADE TO PART	ECN #	AUTHOR/ APPROVAL
REVISION BLOCK				

UNLESS OTHERWISE SPECIFIED, DIMENSIONS ARE IN INCHES
 DIMENSIONS AND TOLERANCING PER ANSI Y14.5
 SURFACE ROUGHNESS PER ANSI Y14.36

BLOCK TOLERANCING PER DECIMAL:
 .X = ±.030 .XX = ±.010 .XXX = ±.005 .XXXX = ±.0005
 ANGLE = ±0° 30'

REMOVE BURRS AND SHARP EDGES: R.015 MAX
 MACHINE SURFACE FINISH: 125 RMS OR BETTER

DRAWINGS AND TECHNICAL DOCUMENTS CONTROLLED BY:
ACRADYNE MECHANICAL ENGINEERING

AEN33042C ANGLE NUTRUNNER
 3000 SERIES, GEN 3C, 3/8" SQ. DR.

SIZE D	PART / DRAWING NUMBER AEN33042C	REVISION A
SCALE 1:1	DO NOT SCALE DRAWING	SHEET 1 OF 2

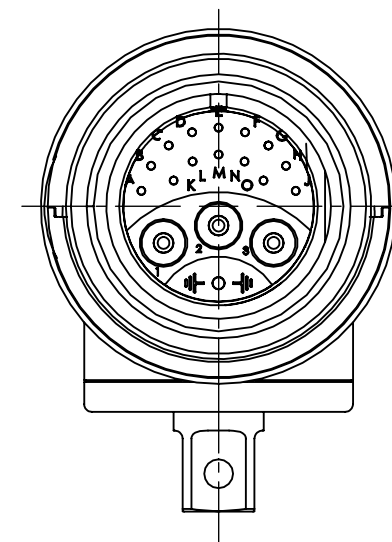
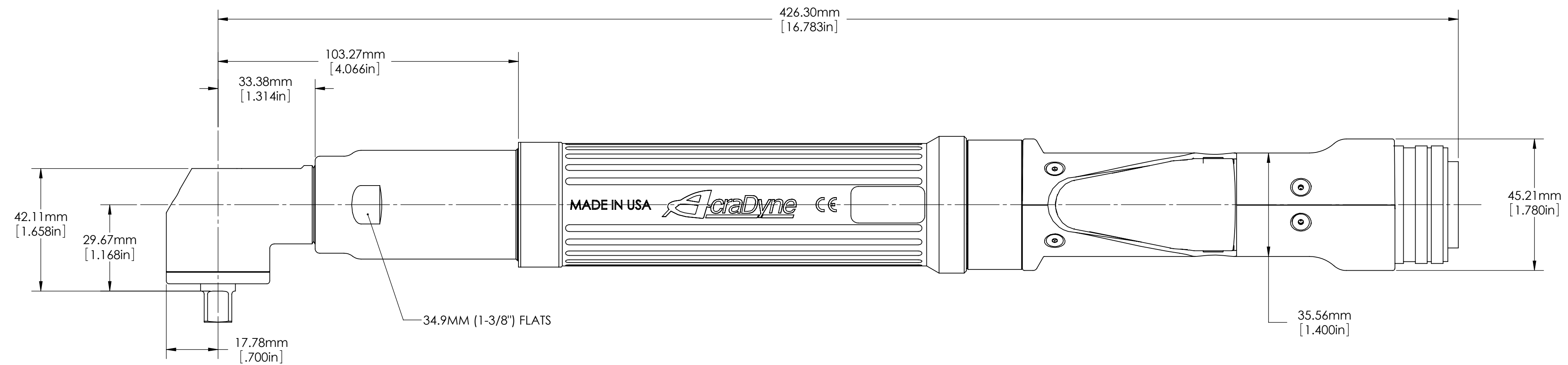
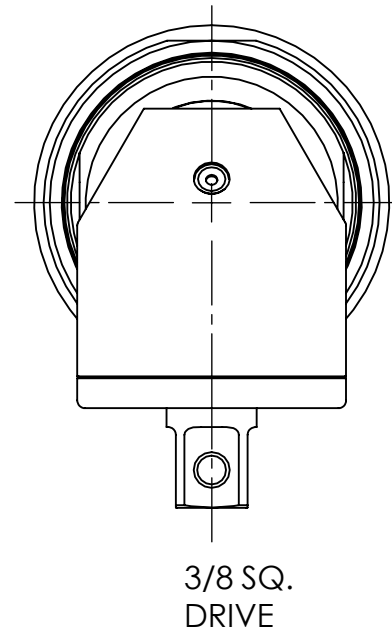
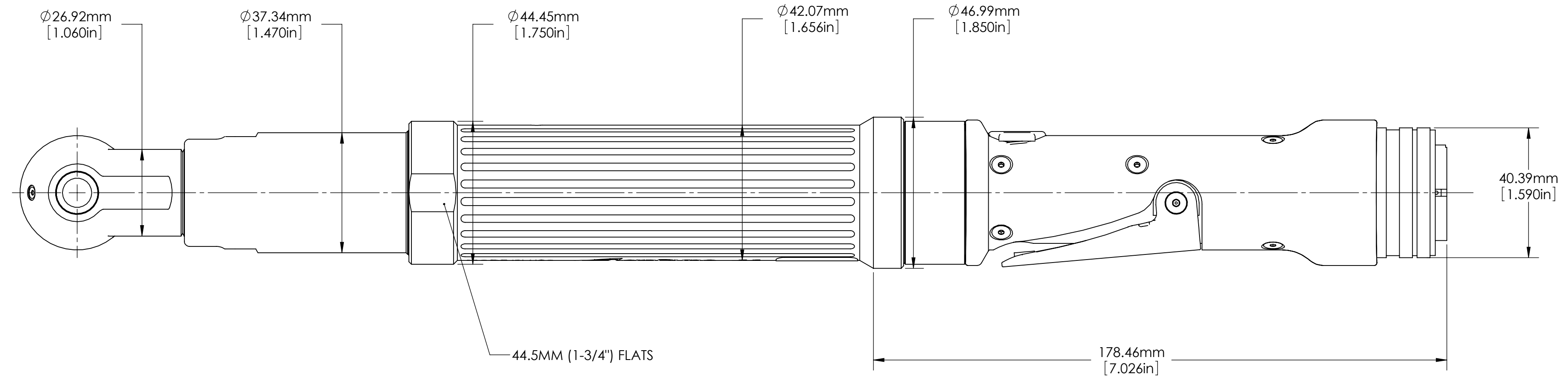

DOCUMENT CONTROL
PRINTED COPIES OF THIS DOCUMENT ARE CONSIDERED TO BE UNCONTROLLED DOCUMENTS. HOLDERS ARE RESPONSIBLE FOR VERIFYING THE CURRENT REVISION LEVEL WITH PURCHASING OR ENGINEERING PRIOR TO USE OR FABRICATION. THE CONTROLLED VERSION OF THIS DOCUMENT IS ELECTRONICALLY MAINTAINED.

PROPRIETARY AND CONFIDENTIAL
THIS DRAWING CONTAINS INFORMATION STRICTLY CONFIDENTIAL TO ACRADYNE/AIMCO. IN THE ABSENCE OF EXPRESSED WRITTEN PERMISSION, ACRADYNE/AIMCO HAS LOANED THIS COPY WITH THE MUTUAL UNDERSTANDING THAT (A) IT WILL NOT BE USED FOR ANY PURPOSE OTHER THAN FOR THAT IN WHICH IT WAS PROVIDED, (B) THE DATA CONTAINED HEREIN WILL NOT BE DISCLOSED TO OTHERS, (C) IT WILL NOT BE REPRODUCED, AND (D) IT WILL BE RETURNED TO ACRADYNE/AIMCO IMMEDIATELY UPON DEMAND.

REVISION LEVEL	REVISION RELEASE DATE	DESCRIPTION OF CHANGES MADE TO PART	ECN #	AUTHOR/ APPROVAL
REVISION BLOCK				

UNLESS OTHERWISE SPECIFIED, DIMENSIONS ARE IN INCHES
DIMENSIONS AND TOLERANCING PER ANSI Y14.5
SURFACE ROUGHNESS PER ANSI Y14.36

BLOCK TOLERANCING PER DECIMAL:
X = ±.030 .XX = ±.010 .XXX = ±.005 .XXXX = ±.0005
ANGLE = ±0° 30'

REMOVE BURRS AND SHARP EDGES: R.015 MAX
MACHINE SURFACE FINISH: 125 RMS OR BETTER
DRAWINGS AND TECHNICAL DOCUMENTS CONTROLLED BY:
ACRADYNE MECHANICAL ENGINEERING

AEN33042C
TOOL OUTLINE
3000 SERIES, GEN 3C

SIZE	PART / DRAWING NUMBER	REVISION
D	AEN33042C	A
SCALE 1:1	DO NOT SCALE DRAWING	SHEET 2 OF 2