

MODEL NO.	ANGLEHEAD/GEAR TRAIN ASM.
AEN33060CVDL	31579
AEN33090CVDL	31578

COMMENTS	ITEM NO.	PART NUMBER	QTY.	DESCRIPTION
	1	27625	1	HOUSING MOTOR/HANDLE, DUAL LEVER
	2	25525	1	MOTOR ASSY, 9T, 3000 SERIES
	3	25063	1	LED BOARD ASM.
	4	SEE CHART	1	GEAR TRAIN ASM., ANGLEHEAD, EXT. OUTPUT, 60mm
	5	25075	2	SCREW, SHC 4-40X.375, STEEL, BLACK OXIDE
	6	25430	2	STAND-OFF, LED, 3000 SERIES
	7	27027	1	SCREW, SET 5-40X.188,STEEL,BLK OXIDE
	8	26793	2	RETAINING PIN, .125 OD X 1-1/4
	9	26102	1	TOOL CONNECTOR ASM., LEVER
	10	25745	5	SCREW, BHSC 4-40 STEEL, BLACK OXIDE
	11	25847	1	TID BOARD ASM., 2000-3000 SERIES
	12	24934	2	SCREW, FHC 4-40 X .312, STEEL, BLACK OXIDE
	13	20132	1	THROTTLE SPRING
	14	26532	1	GEN 3 TRIGGER ASSY, CAST
	15	20061	2	SCREW, LEVER
	16	25072	1	O-RING, LED LIGHT RING C.OVER
	17	20534	1	3000 SERIAL/MODEL LABEL
	18	25058	1	LIGHT RING COVER, LED
	19	26084	1	HANDLE COVER, MFB
	20	24706	1	REV BUTTON SUB-ASSEMBLY
	21	24683	1	SPRING, REV BUTON
	22	24679	1	RETAINING RNG
	23	24940	10	SCREW, FHSC 4-40 X .25 LG., STEEL, BLACK OXIDE
	24	26083	1	HANDLE COVER
	25	22141	1	SAFETY LABEL
	26	26184	2	ADAPTER INSERT, GEN 3B 3000 SERIES
	27	25106	1	PIN RETAINER RING
	28	25107	2	RETAINING RING, PIN RETAINER
	29	25441	1	HALL SWITCH ASM., DUAL LEVER TOOL
	30	25439	2	SCREW, BHC 2-56 X .188, STEEL, BLACK OXIDE
	31	26735	1	DUAL TRIGGER ASSY, 3000 SERIES
	32	25440	2	SCREW, LEVER, DUAL LEVER TOOL
	33	26733	1	SPRING, DUAL LEVER, TAPERED

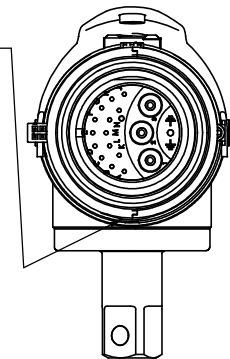
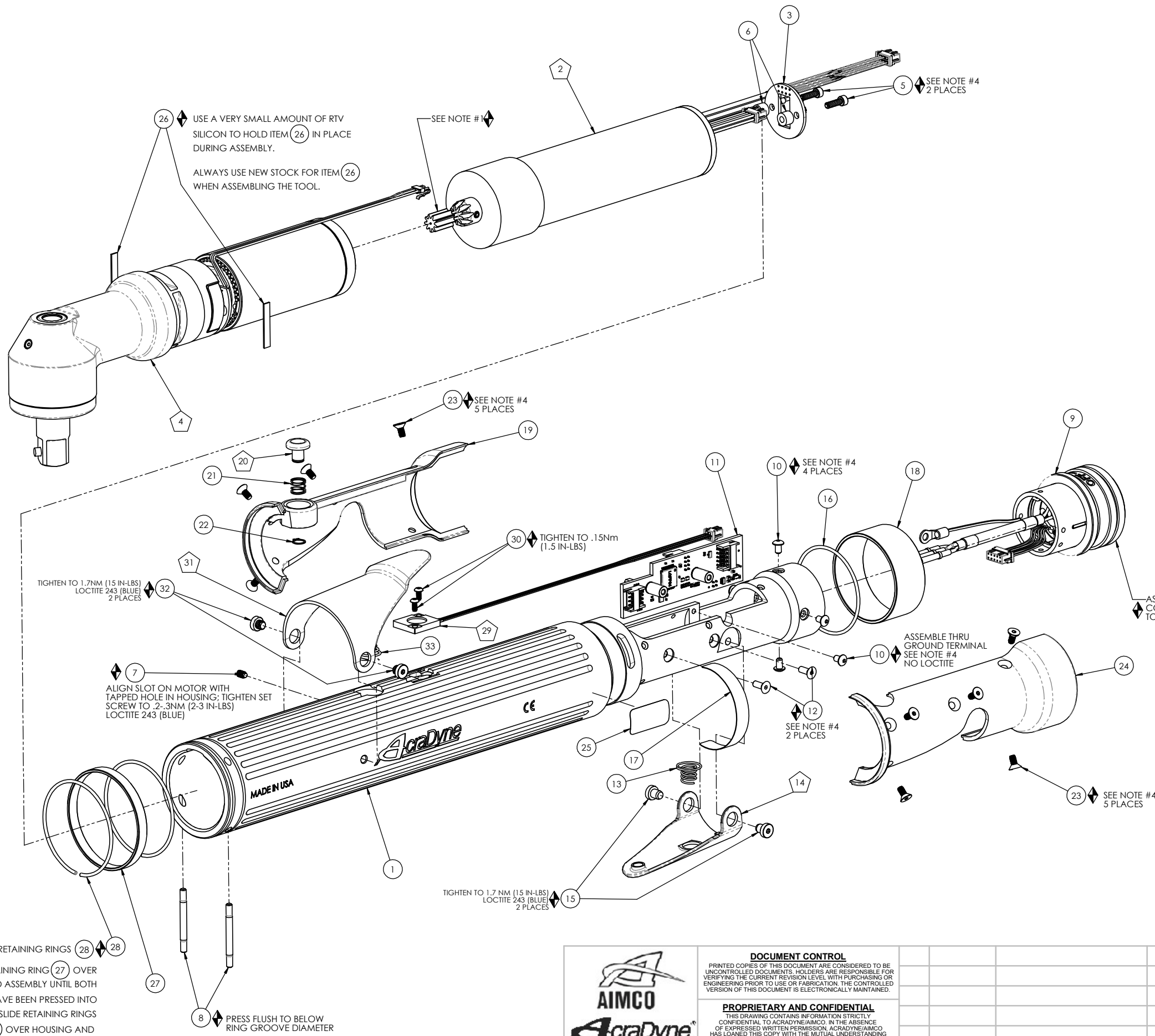

- ◆ ASSEMBLY INSTRUCTIONS
- ◊ SUB-ASSEMBLY
- 1) GEARS & SPLINES: LUBRICATE WITH DOW CORNING MOLYKOTE BR2 PLUS GREASE.
- 2) BEARINGS: LUBRICATE WITH CHEVRON SR1 GREASE
- 3) O-RINGS: LUBRICATE WITH O-RING LUBE
- 4) TIGHTEN TO 1.0 NM (9IN-LBS) LOCTITE 243 (BLUE)

ASSEMBLE RETAINING RINGS (28) AND PIN RETAINING RING (27) OVER ANGLEHEAD ASSEMBLY UNTIL BOTH ITEM (8) PINS HAVE BEEN PRESSED INTO HOUSING. THEN SLIDE RETAINING RINGS (27) & (28) OVER HOUSING AND INTO GROOVES

8 PRESS FLUSH TO BELOW RING GROOVE DIAMETER



DOCUMENT CONTROL
 PRINTED COPIES OF THIS DOCUMENT ARE CONSIDERED TO BE UNCONTROLLED DOCUMENTS. HOLDERS ARE RESPONSIBLE FOR VERIFYING THE CURRENT REVISION LEVEL WITH PURCHASING OR ENGINEERING PRIOR TO USE OR FABRICATION. THE CONTROLLED VERSION OF THIS DOCUMENT IS ELECTRONICALLY MAINTAINED.

PROPRIETARY AND CONFIDENTIAL
 THIS DRAWING CONTAINS INFORMATION STRICTLY CONFIDENTIAL TO ACRADYNE/AIMCO. IN THE ABSENCE OF EXPRESSED WRITTEN PERMISSION, ACRADYNE/AIMCO HAS LOANED THIS COPY WITH THE MUTUAL UNDERSTANDING THAT (A) IT WILL NOT BE USED FOR ANY PURPOSE OTHER THAN FOR THAT IN WHICH IT WAS PROVIDED, (B) THE DATA CONTAINED HEREIN WILL NOT BE DISCLOSED TO OTHERS, (C) IT WILL NOT BE REPRODUCED, AND (D) IT WILL BE RETURNED TO ACRADYNE/AIMCO IMMEDIATELY UPON DEMAND.

REVISION LEVEL	REVISION RELEASE DATE	DESCRIPTION OF CHANGES MADE TO PART	ECN #	AUTHOR/ APPROVAL

UNLESS OTHERWISE SPECIFIED, DIMENSIONS ARE IN INCHES
 DIMENSIONS AND TOLERANCING PER ANSI Y14.5 SURFACE ROUGHNESS PER ANSI Y14.36

BLOCK TOLERANCING PER DECIMAL:
 .X = ±.030 .XX = ±.010 .XXX = ±.005 .XXXX = ±.0005
 ANGLE = ±0° 30'

REMOVE BURRS AND SHARP EDGES: R.015 MAX MACHINE SURFACE FINISH: 125 RMS OR BETTER

DRAWINGS AND TECHNICAL DOCUMENTS CONTROLLED BY:
ACRADYNE MECHANICAL ENGINEERING

AEN330 CVDL DUAL LEVER ANGLE NUTRUNNER 3000-SERIES GEN 3C

SIZE D	PART / DRAWING NUMBER AEN330 CVDL	REVISION A
SCALE: 1:1	DO NOT SCALE DRAWING	SHEET 1 OF 2

8 7 6 5 4 3 2 1

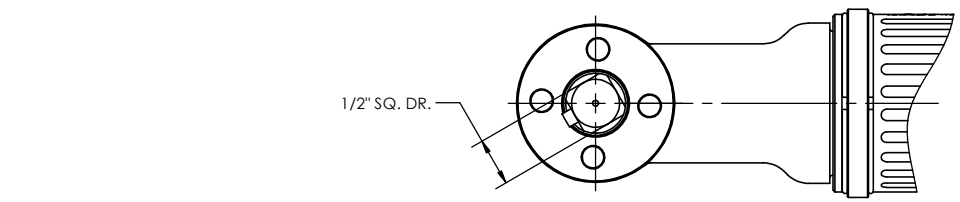
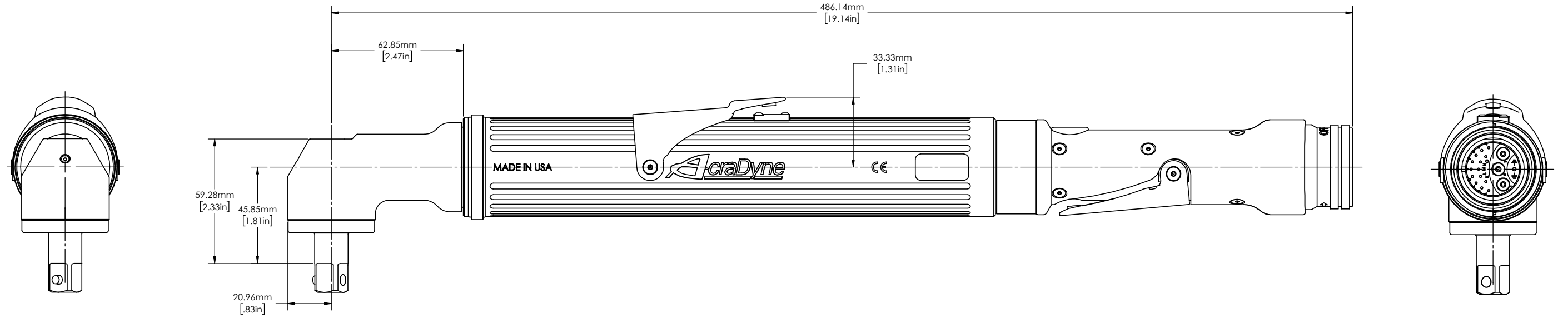
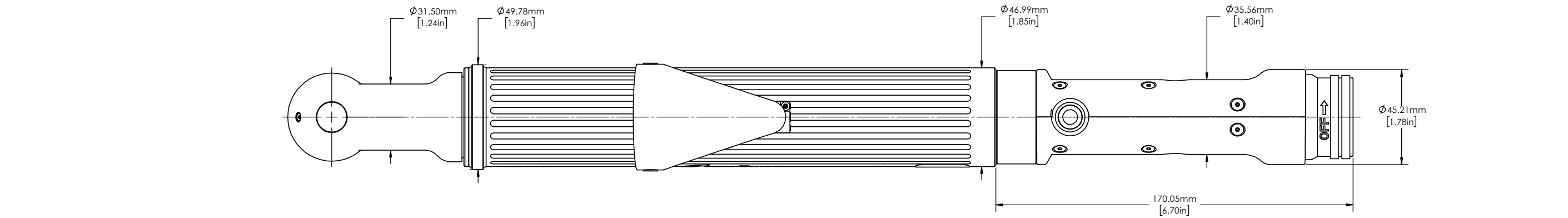

DOCUMENT CONTROL
 PRINTED COPIES OF THIS DOCUMENT ARE CONSIDERED TO BE UNCONTROLLED DOCUMENTS. HOLDERS ARE RESPONSIBLE FOR VERIFYING THE CURRENT REVISION LEVEL WITH PURCHASING OR ENGINEERING PRIOR TO USE OR FABRICATION. THE CONTROLLED VERSION OF THIS DOCUMENT IS ELECTRONICALLY MAINTAINED.

PROPRIETARY AND CONFIDENTIAL
 THIS DRAWING CONTAINS INFORMATION STRICTLY CONFIDENTIAL TO ACRADYNE/AIMCO. IN THE ABSENCE OF EXPRESSED WRITTEN PERMISSION, ACRADYNE/AIMCO HAS LOANED THIS COPY WITH THE MUTUAL UNDERSTANDING THAT (A) IT WILL NOT BE USED FOR ANY PURPOSE OTHER THAN FOR THAT IN WHICH IT WAS PROVIDED, (B) THE DATA CONTAINED HEREIN WILL NOT BE DISCLOSED TO OTHERS, (C) IT WILL NOT BE REPRODUCED, AND (D) IT WILL BE RETURNED TO ACRADYNE/AIMCO IMMEDIATELY UPON DEMAND.

REVISION LEVEL	REVISION RELEASE DATE	DESCRIPTION OF CHANGES MADE TO PART	ECN #	AUTHOR/ APPROVAL

UNLESS OTHERWISE SPECIFIED, DIMENSIONS ARE IN INCHES
 DIMENSIONS AND TOLERANCING PER ANSI Y14.5
 SURFACE ROUGHNESS PER ANSI Y14.36

BLOCK TOLERANCING PER DECIMAL:
 .X = ±.030 .XX = ±.010 .XXX = ±.005 .XXXX = ±.0005
 ANGLE = ±0° 30'

REMOVE BURRS AND SHARP EDGES: R.015 MAX
 MACHINE SURFACE FINISH: 125 RMS OR BETTER

DRAWINGS AND TECHNICAL DOCUMENTS CONTROLLED BY:
ACRADYNE MECHANICAL ENGINEERING

AEN330_CVDL DUAL LEVER ANGLE NUTRUNNER
 3000-SERIES, GEN 3C

SIZE	PART / DRAWING NUMBER	REVISION
D	AEN330_CVDL	A

SCALE: 1:1 DO NOT SCALE DRAWING SHEET 2 OF 2

8 7 6 5 4 3 2 1