

COMMENTS	ITEM NO.	PART NUMBER	QTY.	DESCRIPTION
	1	26212	1	MOTOR ASM., 7000 SERIES
	2	26227	1	O-RING, MOTOR HOUSING
	3	25574	4	STANDOFF M-F, 4-40x1/4, 3/16 HEX, SS
	4	27727	1	TID BOARD, POPULATED W/AMP
	5	25573	8	SCREW PHP 4-40 X 3/16 18-8 SS
	6	SEE CHART	1	GEAR BOX ASM.
	7	26299	1	O-RING, PINION
	8	29279	6	SCREW, BHSC, 10-32 x 3/8, TORX HEAD, NYLON PELL-IT, STEEL
	9	26275	1	HANDLE, PISTOL
	10	26206	6	SCREW, BHSC 10-32 X .375, STEEL
	11	26288	1	TOOL CONNECTOR ASM., PISTOL
	12	25745	4	SCREW, BHSC 4-40 STEEL, BLACK OXIDE
	13	26289	1	SWITCH SUB-ASSEMBLY
NOT SHOWN	14	26526	1	CABLE, TRIGGER, GEN 4 PISTOL
	15	26224	1	TRAY, WIRE, PISTOL, INJECTION MOLDED
	16	28211	1	(4) LINE MALE/FEMALE JUMPER ASM.
	17	26226	1	O-RING, LED COVER
	18	20534	1	3000 SERIAL/MODEL LABEL
	19	26223	1	LED COVER
	20	26220	1	END CAP, PISTOL
	21	26228	4	SCREW, BHSC 10-32X1.50, STEEL, BLACK OXIDE
	22	26525	1	PLUG 5/16"
	23	SEE CHART	1	GEAR CASE COVER
	24	26319	3	SCREW, BHSC 6-32 X .188, 18-8 SS
	25	26897	1	CHOOSE REACTION BAR
	26	26243	1	RETAINING RING, SPIRAL, Ø2.864 X Ø2.464 X .078
NOT SHOWN	27	27464	A/R	TWISTED WAXED LINEN TWINE
	28	29337	3	STANDOFF, M-F, 4-40 X 1/8, SS
	29	29336	1	TID BOARD WIRE INSULATOR
	30	31410	1	GROUND WIRE ASSEMBLY, 18 AWG, 6000 & 7000 HT SERIES

TOOL MODEL	GEAR BOX ASM.	GEAR CASE COVER
AEP4A771000B	28110	26298
AEP4A772500B	28111	26295

ASSEMBLY INSTRUCTIONS
SUB-ASSEMBLY

- GEARS & SPLINES: LUBRICATE WITH DOW CORNING MOLYKOTE BR2 PLUS GREASE.
- BEARINGS: LUBRICATE WITH CHEVRON SR1 GREASE
- O-RINGS: LUBRICATE WITH O-RING LUBE



DOCUMENT CONTROL
PRINTED COPIES OF THIS DOCUMENT ARE CONSIDERED TO BE UNCONTROLLED DOCUMENTS. HOLDERS ARE RESPONSIBLE FOR VERIFYING THE CURRENT REVISION LEVEL WITH PURCHASING OR ENGINEERING PRIOR TO USE OR FABRICATION. THE CONTROLLED VERSION OF THIS DOCUMENT IS ELECTRONICALLY MAINTAINED.

PROPRIETARY AND CONFIDENTIAL
THIS DRAWING CONTAINS INFORMATION STRICTLY CONFIDENTIAL TO ACRADYNE/AIMCO. IN THE ABSENCE OF EXPRESSED WRITTEN PERMISSION, ACRADYNE/AIMCO HAS LOANED THIS COPY WITH THE MUTUAL UNDERSTANDING THAT (A) IT WILL NOT BE USED FOR ANY PURPOSE OTHER THAN FOR THAT IN WHICH IT WAS PROVIDED, (B) THE DATA CONTAINED HEREIN WILL NOT BE DISCLOSED TO OTHERS, (C) IT WILL NOT BE REPRODUCED, AND (D) IT WILL BE RETURNED TO ACRADYNE/AIMCO IMMEDIATELY UPON DEMAND.

UNLESS OTHERWISE SPECIFIED, DIMENSIONS ARE IN INCHES
DIMENSIONS AND TOLERANCING PER ANSI Y14.5 SURFACE ROUGHNESS PER ANSI Y14.36

BLOCK TOLERANCING PER DECIMAL:
X = ±.030 XX = ±.010 XXX = ±.005 XXXX = ±.0005
ANGLE = ±30°

REMOVE BURRS AND SHARP EDGES: R.015 MAX MACHINE SURFACE FINISH: 125 RMS OR BETTER

DRAWINGS AND TECHNICAL DOCUMENTS CONTROLLED BY:
ACRADYNE MECHANICAL ENGINEERING

**PISTOL NUTRUNNER
7000 SERIES**

SIZE	PART / DRAWING NUMBER	REVISION
D	AEP4A77_00B	D

SCALE 1:2 DO NOT SCALE DRAWING SHEET 1 OF 2

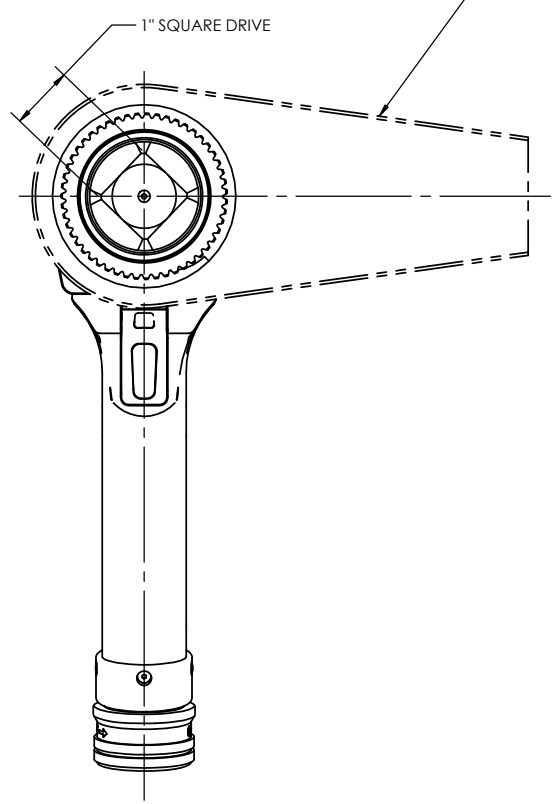

NOTE:
REACTION BAR GEOMETRY
TO CHANGE DEPENDING
ON REACTION BAR CHOSEN.

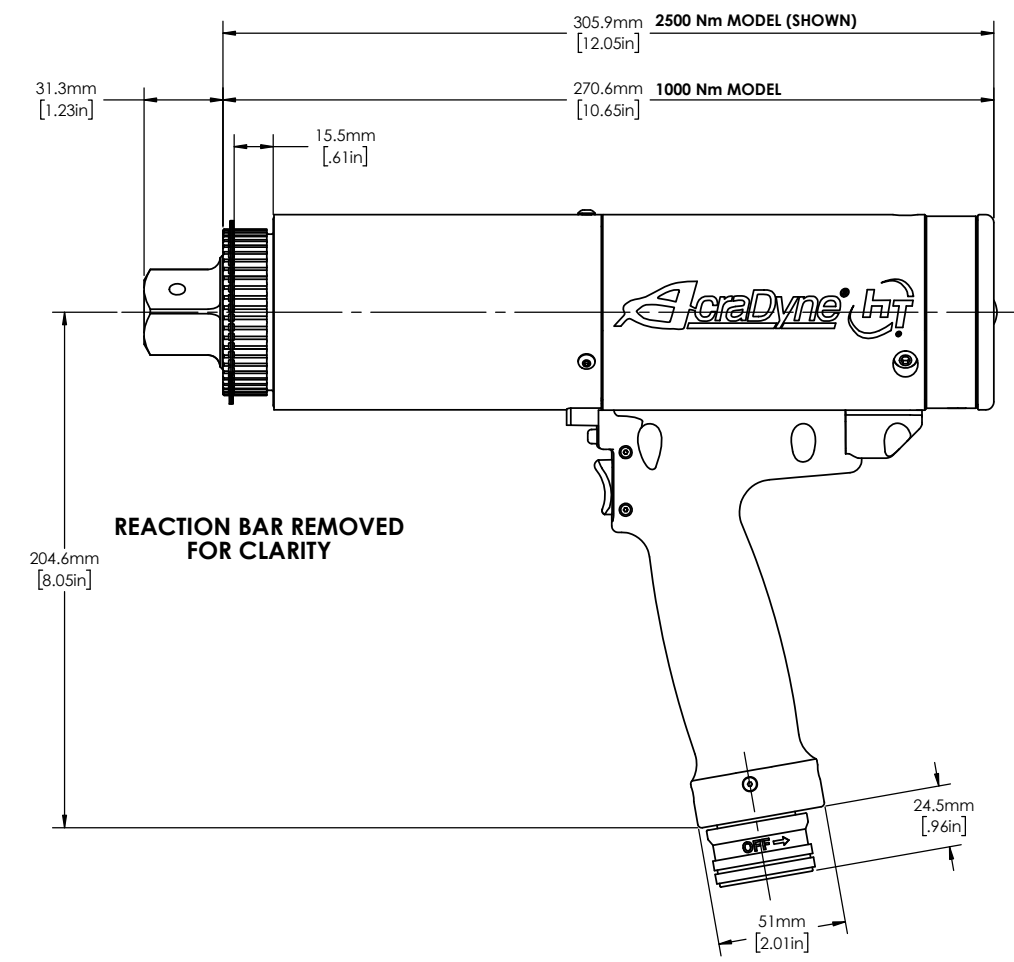
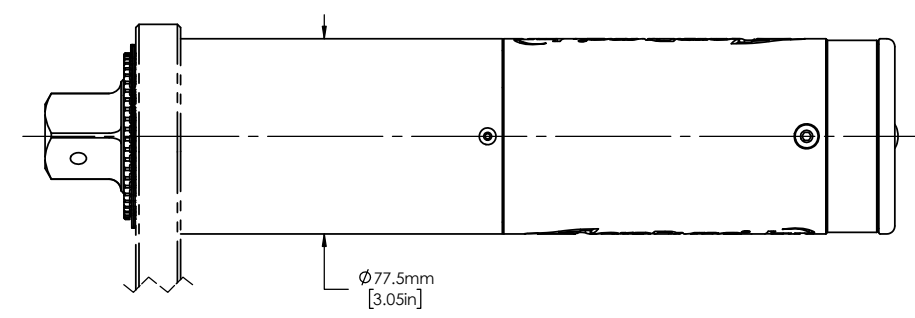

MODEL NO.
AEP4A771000B
AEP4A772500B

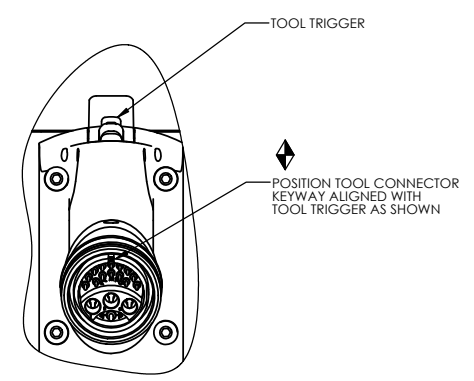

DOCUMENT CONTROL
PRINTED COPIES OF THIS DOCUMENT ARE CONSIDERED TO BE UNCONTROLLED DOCUMENTS. HOLDERS ARE RESPONSIBLE FOR VERIFYING THE CURRENT REVISION LEVEL WITH PURCHASING OR ENGINEERING PRIOR TO USE OR FABRICATION. THE CONTROLLED VERSION OF THIS DOCUMENT IS ELECTRONICALLY MAINTAINED.

PROPRIETARY AND CONFIDENTIAL
THIS DRAWING CONTAINS INFORMATION STRICTLY CONFIDENTIAL TO ACRADYNE/AIMCO. IN THE ABSENCE OF EXPRESSED WRITTEN PERMISSION, ACRADYNE/AIMCO HAS LOANED THIS COPY WITH THE MUTUAL UNDERSTANDING THAT (A) IT WILL NOT BE USED FOR ANY PURPOSE OTHER THAN FOR THAT IN WHICH IT WAS PROVIDED, (B) THE DATA CONTAINED HEREIN WILL NOT BE DISCLOSED TO OTHERS, (C) IT WILL NOT BE REPRODUCED, AND (D) IT WILL BE RETURNED TO ACRADYNE/AIMCO IMMEDIATELY UPON DEMAND.

UNLESS OTHERWISE SPECIFIED, DIMENSIONS ARE IN INCHES
DIMENSIONS AND TOLERANCING PER ANSI Y14.5
SURFACE ROUGHNESS PER ANSI Y14.36

BLOCK TOLERANCING PER DECIMAL:
.X = ±.030 .XX = ±.010 .XXX = ±.005 .XXXX = ±.0005
ANGLE = ±0°30'

REMOVE BURRS AND SHARP EDGES: R.015 MAX
MACHINE SURFACE FINISH: 125 RMS OR BETTER

DRAWINGS AND TECHNICAL DOCUMENTS CONTROLLED BY:
ACRADYNE MECHANICAL ENGINEERING

PISTOL NUTRUNNER		
7000 SERIES		
SIZE	PART / DRAWING NUMBER	REVISION
D	AEP4A77_00B	D
SCALE 1:1	DO NOT SCALE DRAWING	SHEET 2 OF 2