

COMMENTS	ITEM NO.	PART NUMBER	QTY.	DESCRIPTION
	1	25065	1	PISTOL MOTOR ASSEMBLY, TOP EXIT
	2	26599	1	LED PCB ASSY, PISTOL
	3	27016	2	NUT, HEX, 4-40 UNDERSIZED, STEEL ZINC
	4	24780	1	MOTOR COUPLER SUB-ASM.
	5	25763	1	TRANSDUCER ADAPTOR
	6	SEE CHART	1	TRANSDUCER SUB-ASM.
	7	SEE CHART	1	GEAR CASE SUB-ASM.
	8	24698	1	STRAIGHT OUTPUT ASM., 3/8" SQ. DR., 2000 SERIES
	9	24687	1	O-RING, LIGHT RING, LEVER
	10	24873	1	LIGHT RING
	11	24686	1	RETAINING RING, LEVER LIGHT RING
	12	26685	1	PISTOL HANDLE, 2000 SERIES, MODEL B
	13	25871	1	SWITCH SUB-ASSEMBLY
	14	24934	2	SCREW, FHC 4-40 X .312, STEEL, BLACK OXIDE
	15	25849	1	T.I.D. BOARD ASM., PISTOL
	16	24697	1	REACTION BAR, STEEL, 2000 SERIES
SEE WIRING PHOTO	17	25788	1	CABLE, TRIGGER, GEN 4 PISTOL
	18	25814	1	SCREW, PAN HEAD PHILLIPS, 4-40 X 3/16, STAR WASH, SS
	19	24909	1	STRAIGHT ADAPTOR, PISTOL TOOL CONNECTOR
	20	25138	2	SCREW, FHC 4-40 X .312, STEEL, BLACK OXIDE
	21	25798	1	PLUG, PISTOL HANDLE
	22	26141	1	TOOL CONNECTOR ASM., FIXTURED TOOLS
	23	26668	4	SCREW, BHSC 6-32x7/16, STEEL, BLACK OXIDE
	24	26791	4	WASHER, FLAT, NO 6 SCREW, STEEL, BLACK OXIDE
	25	25271	A/R	SHIM. - .002
	26	25272	A/R	SHIM. - .005
	27	25273	A/R	SHIM. - .010

MODEL NO.	TRANSDUCER SUB-ASM.	GEAR CASE SUB-ASM.
AEP4R22020B	25761.009 (20Nm)	24901 (14T/14T)
AEP4R22025B	25762.001 (40Nm)	24894 (12T/12T)
AEP4R22030B	25762.002 (40Nm)	24902 (8T/14T)
AEP4R22035B	25762.003 (40Nm)	24903 (8T/12T)
AEP4R22040B	25762.004 (40Nm)	24904 (6T/14T)

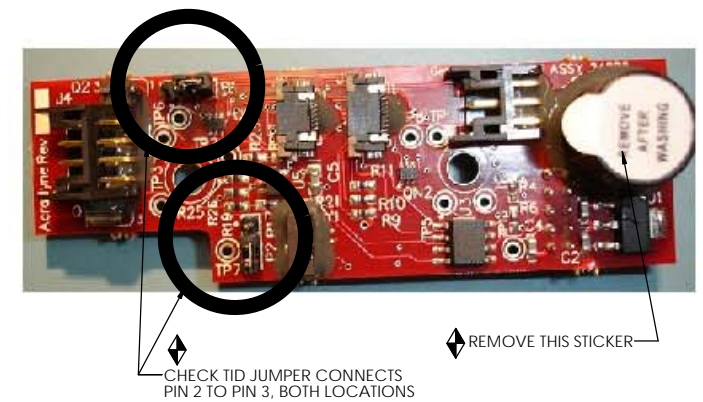

◆ PRE-WIRE PISTOL AND PROGRAM TID TO TEST MOTOR, CABLING AND TID BOARD BEFORE ASSEMBLING INTO HANDLE

- ◆ ASSEMBLY INSTRUCTIONS
 - ◇ SUB-ASSEMBLY
- 1) GEARS & SPLINES: LUBRICATE WITH DOW CORNING MOLYKOTE BR2 PLUS GREASE.
 - 2) BEARINGS: LUBRICATE WITH CHEVRON SR1 GREASE
 - 3) O-RINGS: LUBRICATE WITH O-RING LUBE
 - 4) TIGHTEN TO 1.0 Nm (9IN-LBS) LOCTITE 243 (BLUE)

REQUIRED TOOLING
SNAP-ON CROWFOOT WRENCH, 1/2" SQ. DR. X 1-3/8" OPENING SNAP-ON PART NUMBER SC044
MAGNETIC VISE JAWS - PART NUMBER 1000-100
LOCTITE #243 BLUE
TORQUE WRENCH, 1/2" DRIVE LOCTITE #263 RED



DOCUMENT CONTROL
PRINTED COPIES OF THIS DOCUMENT ARE CONSIDERED TO BE UNCONTROLLED DOCUMENTS. HOLDERS ARE RESPONSIBLE FOR VERIFYING THE CURRENT REVISION LEVEL WITH PURCHASING OR ENGINEERING PRIOR TO USE OR FABRICATION. THE CONTROLLED VERSION OF THIS DOCUMENT IS ELECTRONICALLY MAINTAINED.

PROPRIETARY AND CONFIDENTIAL
THIS DRAWING CONTAINS INFORMATION STRICTLY CONFIDENTIAL TO ACRADYNE/AIMCO. IN THE ABSENCE OF EXPRESSED WRITTEN PERMISSION, ACRADYNE/AIMCO HAS LOANED THIS COPY WITH THE MUTUAL UNDERSTANDING THAT (A) IT WILL NOT BE USED FOR ANY PURPOSE OTHER THAN FOR THAT IN WHICH IT WAS PROVIDED, (B) THE DATA CONTAINED HEREIN WILL NOT BE DISCLOSED TO OTHERS, (C) IT WILL NOT BE REPRODUCED, AND (D) IT WILL BE RETURNED TO ACRADYNE/AIMCO IMMEDIATELY UPON DEMAND.

REVISION LEVEL	REVISION RELEASE DATE	DESCRIPTION OF CHANGES MADE TO PART	ECN #	AUTHOR/ APPROVAL
REVISION BLOCK				

UNLESS OTHERWISE SPECIFIED, DIMENSIONS ARE IN INCHES
DIMENSIONS AND TOLERANCING PER ANSI Y14.5
SURFACE ROUGHNESS PER ANSI Y14.36

BLOCK TOLERANCING PER DECIMAL:
.X = ±.030 .XX = ±.010 .XXX = ±.005 .XXXX = ±.0005
ANGLE = ±0° 30'

REMOVE BURRS AND SHARP EDGES: R.015 MAX
MACHINE SURFACE FINISH: 125 RMS OR BETTER

DRAWINGS AND TECHNICAL DOCUMENTS CONTROLLED BY:
ACRADYNE MECHANICAL ENGINEERING

AEP4R22 ___ B PISTOL NUTRUNNER GEN IV, 2000 SERIES		
SIZE	PART / DRAWING NUMBER	REVISION
D	AEP4R22 ___ B	F
SCALE 1:1	DO NOT SCALE DRAWING	SHEET 1 OF 2

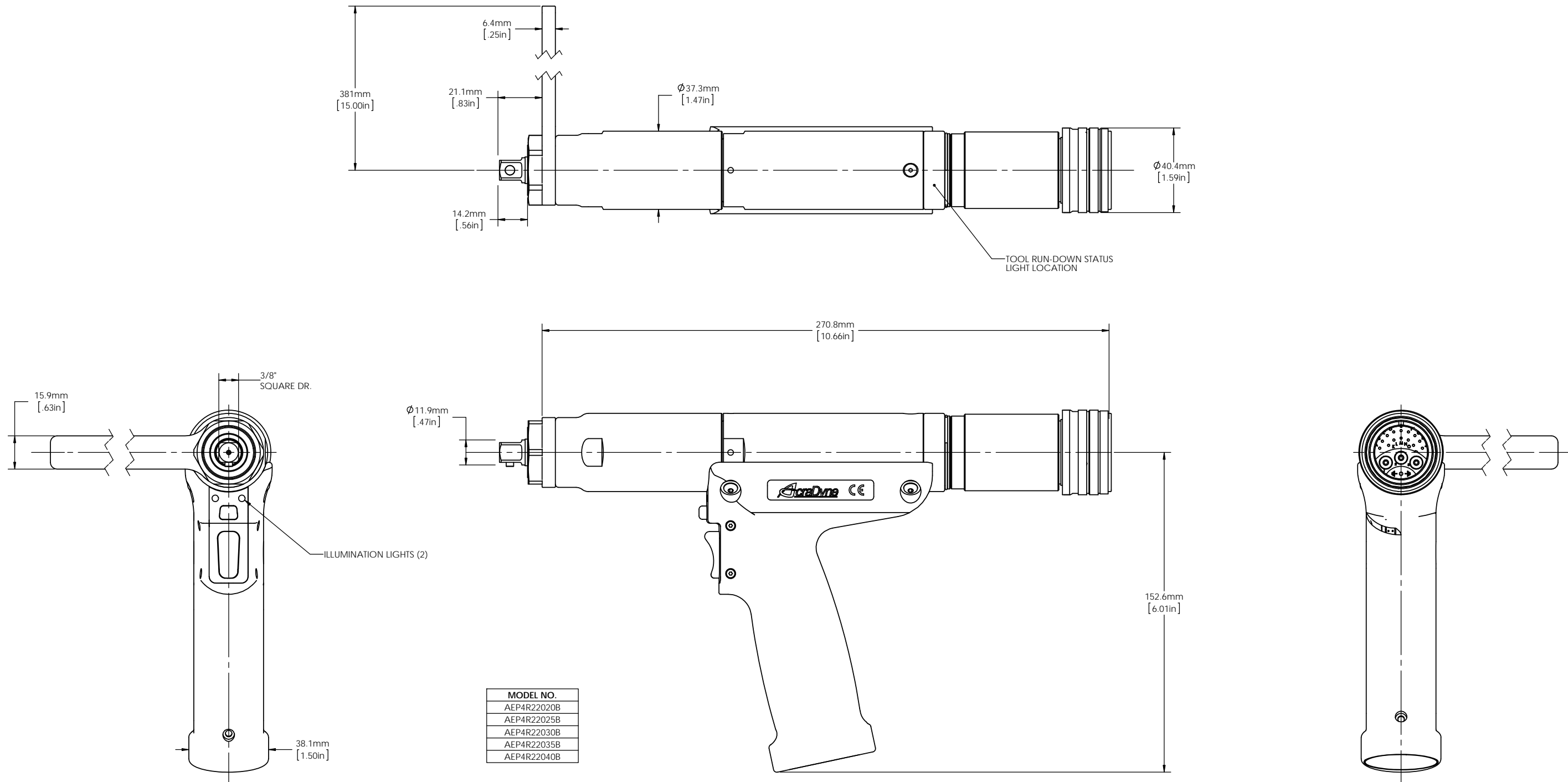

MODEL NO.
AEP4R22020B
AEP4R22025B
AEP4R22030B
AEP4R22035B
AEP4R22040B



DOCUMENT CONTROL
 PRINTED COPIES OF THIS DOCUMENT ARE CONSIDERED TO BE UNCONTROLLED DOCUMENTS. HOLDERS ARE RESPONSIBLE FOR VERIFYING THE CURRENT REVISION LEVEL WITH PURCHASING OR ENGINEERING PRIOR TO USE OR FABRICATION. THE CONTROLLED VERSION OF THIS DOCUMENT IS ELECTRONICALLY MAINTAINED.

PROPRIETARY AND CONFIDENTIAL
 THIS DRAWING CONTAINS INFORMATION STRICTLY CONFIDENTIAL TO ACRADYNE/AIMCO. IN THE ABSENCE OF EXPRESSED WRITTEN PERMISSION, ACRADYNE/AIMCO HAS LOANED THIS COPY WITH THE MUTUAL UNDERSTANDING THAT (A) IT WILL NOT BE USED FOR ANY PURPOSE OTHER THAN FOR THAT IN WHICH IT WAS PROVIDED, (B) THE DATA CONTAINED HEREIN WILL NOT BE DISCLOSED TO OTHERS, (C) IT WILL NOT BE REPRODUCED, AND (D) IT WILL BE RETURNED TO ACRADYNE/AIMCO IMMEDIATELY UPON DEMAND.

REVISION LEVEL	REVISION RELEASE DATE	DESCRIPTION OF CHANGES MADE TO PART	ECN #	AUTHOR/ APPROVAL
REVISION BLOCK				

UNLESS OTHERWISE SPECIFIED, DIMENSIONS ARE IN INCHES
 DIMENSIONS AND TOLERANCING PER ANSI Y14.5
 SURFACE ROUGHNESS PER ANSI Y14.36

BLOCK TOLERANCING PER DECIMAL:
 .X = ±.030 .XX = ±.010 .XXX = ±.005 .XXXX = ±.0005
 ANGLE = ±0° 30'

REMOVE BURRS AND SHARP EDGES: R.015 MAX
 MACHINE SURFACE FINISH: 125 RMS OR BETTER

DRAWINGS AND TECHNICAL DOCUMENTS CONTROLLED BY:
ACRADYNE MECHANICAL ENGINEERING

AEP4R22 ___ B PISTOL NUTRUNNER GEN IV, 2000 SERIES		
SIZE	PART / DRAWING NUMBER	REVISION
D	AEP4R22 ___ B	F
SCALE 1:1	DO NOT SCALE DRAWING	SHEET 2 OF 2