



**AcraDrive Gen IV
2000 Series DC Pulse
Nutrunners
Operations Manual**



10000 SE Pine St., Portland OR 97216 • 800-852-1368 • Fax 800-582-9015

www.aimco-global.com

INTRODUCTION

Thank you for purchasing this AcraDyne DC electric assembly tool, one of the lightest and fastest DC electric assembly tools on the market. When used with the AcraDyne iEC tool controller, this tool will provide excellent productivity, ergonomics, reliability and quality on a wide range of industrial assembly applications.

Safety Information

SAVE THESE INSTRUCTIONS

1) WORK AREA

- a. Keep work area clean and well lit. Cluttered and dark areas invite accidents.
- b. Do not operate power tools in explosive atmospheres, such as the presence of flammable liquids, gases or dust. Power tools create sparks which may ignite the dust or fumes.
- c. Keep children and bystanders away while operating a power tool. Distractions can cause you to lose control.

2) ELECTRICAL SAFETY

- a. Power tool plugs must match the outlet. Never modify the plug in any way. Do not use any adapter plugs with earthed (grounded) power tools. Unmodified plugs and matching outlets will reduce risk of electric shock.
- b. Avoid body contact with earthed or grounded surfaces such as pipes, radiators, ranges and refrigerators. There is an increased risk of electric shock if your body is earthed or grounded.
- c. Do not expose power tools to rain or wet conditions. Water entering a power tool will increase the risk of electric shock.
- d. Do not abuse the cord. Never use the cord for carrying, pulling or unplugging the power tool. Keep cord away from heat, oil, sharp edges or moving parts. Damaged or entangled cords increase the risk of electric shock.
- e. When operating a power tool outdoors, use an extension cord suitable for outdoor use. Use of a cord suitable of outdoor use reduces the risk of electric shock
- f. It is not recommended to use AcraDyne controllers or tools outside or to use an extension cord to connect the controller to a power source.

3) PERSONAL SAFETY

- a. Stay alert, watch what you are doing and use common sense when operating a power tool. Do not use a power tool while you are tired or under the influence of drugs, alcohol or medication. A moment of inattention while operating power tools may result in serious personal injury.
- b. Use safety equipment. Always wear eye protection. Safety equipment such as dust mask, non-skid safety shoes, hard hat, or hearing protection used for appropriate conditions will reduce personal injuries. If the maximum duty cycle of the attached tool is exceeded or the tool temperature exceeds 50° C., then the operator should wear protective hand wear (gloves).
- c. Avoid accidental starting. Ensure the switch is in the off-position before plugging in. Carrying power tools with your finger on the switch or plugging in power tools that have the switch on invites accidents.
- d. Remove any adjusting key or wrench before turning the power tool on. A wrench or a key left attached to a rotating part of the power tool may result in personal injury.
- e. Do not overreach. Keep proper footing and balance at all times. This enables better control of the power tool in unexpected situations.
- f. Dress properly. Do not wear loose clothing or jewelry. Keep your hair, clothing and gloves away from moving parts. Loose clothes, jewelry or long hair can be caught in moving parts.
- g. If devices are provided for the connection of dust extraction and collection facilities, ensure these are connected and properly used. Use of these devices can reduce dust-related hazards.

4) POWER TOOL USE AND CARE

- a. Do not force the power tool. Use the correct power tool for your application. The correct power tool will do the job better and safer at the rate for which it was designed.
- b. Do not use the power tool if the switch does not turn it on and off. Any power tool that cannot be controlled with the switch is dangerous and must be repaired.
- c. This product is designed to be used in combination with the AcraDyne iEC DC tool controller for intermittent hand-held or fixtured assembly processes.

OPERATIONS



1. Connect tool cable to the iEC controller and the tool:

The tool cable has curved alignment tabs and slots built into the connectors at each end to ensure proper alignment and connection with the tool and controller.

Make sure that power is not turned on at the controller before making any connections. Align the female connector on the cable with the male connector on the tool and insert the cable onto the tool, then slide the connector nut onto the threads on the cable and turn clockwise until hand-tight.

Align the male connector tab on the other end of the tool cable with the female slot on the controller and insert the cable into the connector, then slide the metal outer cover onto the connection threads on the controller and turn clockwise until hand-tight.

2. Multifunction Button Operation:

The tool will flash all LED lights three times when power is first turned on at the controller. After the controller finishes initializing and displays a target torque value, the multifunction button (MFB) is used to toggle the tool from clockwise mode (FWD) to counter-clockwise operation mode (REV). The MFB is the small button above the trigger.

The tool will initially start in clockwise mode and will have no LED lights turned on. If the trigger is pressed, the tool will turn on the blue LED meaning the tightening operation is underway. Pressing the MFB will cause the tool to flash

yellow and red LED lights. Pressing the MFB again will switch the tool back FWD mode and will indicate this with no LED lights turned on.

3. Start Lever Operation:

To start the tool, depress the start lever. Blue LED lights will be displayed while tightening a bolt. The tool will stop automatically when it senses its target torque value or if no torque is sensed in a specified time period. After a cycle is complete, the tool will display green LED lights for a success, or red LED lights for failure to reach torque/angle.

Light Ring Light Assignment

The Buzzer and Multi-Function Button are programmable in the DSP Menu of ToolWare.

Light Color	Meaning
Green Solid	OK
Red Flashing	Torque Low
Red Solid	Torque High
Yellow Flashing	Angle Low
Yellow Solid	Angle High
Blue Solid	Tool In-Cycle/Tool Armed
Blue Flashing	P-Set Change thru MFB
All On Flashing	Tool in Disassembly
Buzzer	Bad Assembly/Tool in Disassembly/Power Up

A complete tool system consists of the following items:



iEC Controller



Power cord



Tool



Tool Cable

AEP4P22030AV, AEP4P22050AV DC PULSE PISTOL TOOL

EXPLODED VIEW

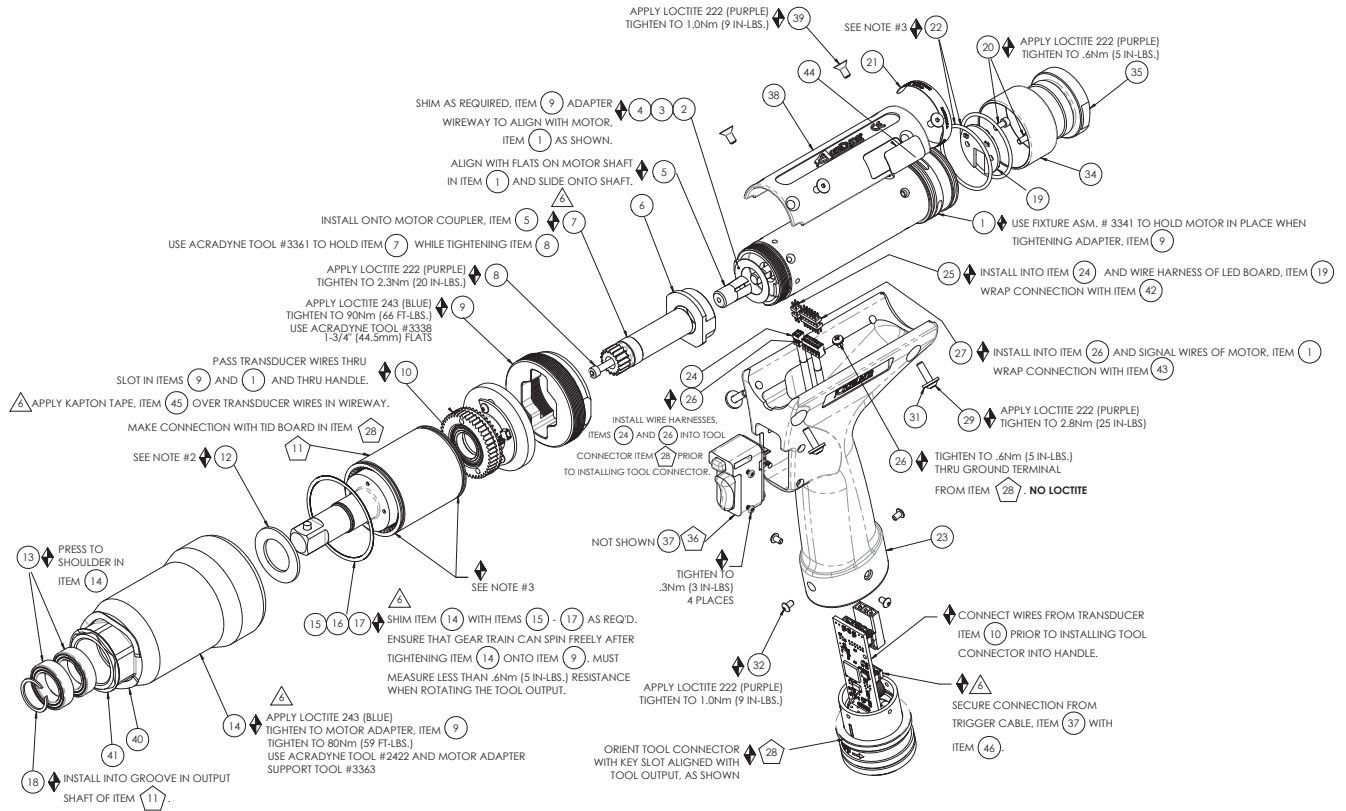

◆ ASSEMBLY INSTRUCTIONS

◊ SUB-ASSEMBLY

- 1) GEARS & SPLINES: LUBRICATE WITH DOW CORNING MOLYKOTE BR2 PLUS GREASE.
- 2) BEARINGS: LUBRICATE WITH CHEVRON SR1 GREASE
- 3) O-RINGS: LUBRICATE WITH O-RING LUBE

PARTS LIST — FOR REFERENCE ONLY

Index Number	Part Number	Description	Qty.
1	28766	Motor Assembly	1
2	21099	Shim, Output Shaft, .010 --- 3000 Series	A/R
3	21098	Shim, Output Shaft, .005 --- 3000-Series	A/R
4	21097	Shim, Output Shaft, .002 --- 3000-Series	A/R
5	31002	Motor Coupler	1
6	31031	Spacer, Motor to Threaded Adapter	1
7	31008	Sun Gear, 21t	1
8	30803	Screw, SHC, 6-32 x 1.25, Black Oxide	1
9	31003	Adapter, Motor to Ring Gear Housing	1
10	31012.002	Transducer Sub-Asm, 30 Nm	1
	31012.003	Transducer Sub-Asm, 50 Nm	1
11	31041	Gear Train Assm, 30 Nm	1
	31020	Gear Train Assm, 50 Nm	1
	31035	Thrust Washer	1
13	31014	Bearing, Radial Ball, Angular Contact, Double Row	2
14	31004	Gear Case Housing, Impact	1
15	26880	Shim, Bearing Retainer, .010	A/R
16	26879	Shim, Bearing Retainer, .005	A/R
17	26878	Shim, Bearing Retainer, .002	A/R
18	31021	Retaining Ring, Single Turn, 17 mm	1
19	30966	LED Board Assm, i2c	1
20	24935	Screw, SHC 4-40 x .25 Steel, Black Oxide	2
21	20534	2000 Serial/Model Label	1
22	27235	O-Ring, Buna-N, #28	2
23	28755	Pistol Handle, Aluminum, 2000-Series, Gen 4c	1

Index Number	Part Number	Description	Qty.
24	31714	LED Jumper Cable Assm., 4 Pin, AcraDrive Pistol Tools	1
25	31711	Header Connector, 4-Pos., .079" (2 mm) Gold	1
26	31715	Signal Jumper Cable Assm., 12 pin, AcraDrive Pistol Tools	1
27	31712	Header Connector, 12-Pos., .079" (2 mm) Gold	1
28	28767	Tool Conn. Assm.	1
29	31727	Screw, BHSC 6-32 x 1/2, Torx, Steel, Black Oxide	4
30 (not shown)	25424	Ground Wire Assm.	1
31	26791	Washer, Flat, No 6 Screw, Steel, Black Oxide	4
32	25745	Screw, BHSC 4-40 Steel, Black Oxide	4
26	25814	Screw, Pan Head Phillips, 4-40 x 3/16, Star Wash, SS	1
34	31062	LED Cover, Fixtured	1
35	28756	End Cap, Pistol	1
	25212	Switch Sub-Assembly	1
37 (not shown)	31713	Trigger Cable Assm., 6 Pin - 6 Pin, AcraDrive Pistol Tools	1
38	28753	Motor Cover, Small Motor O.D.	1
39	23753	Screw, FHSC 6-32 x 5/16, 18-8 SS	4
40	31025	Wave Spring, Split, 1.44 x 1.75 x .018, Steel	1
41	31023	Retaining Ring, Spiral, 1.21 8x 1.454 x .05, Steel	1
42 (not shown)	24173	Heat Shrink, 1/4", Black	A/R
43 (not shown)	24213	Heat Shrink, 1/2" Black	A/R
44	22141	Safety Label	1
45 (not shown)	24263	Kapton Tape, 1/2"	A/R
46 (not shown)	27464	Twisted Waxed Linen Twine	A/R
47 (not shown)	28257	Cable Tie, 1.65 mm x 71 mm	A/R

REVISED 11/21

SPECIFICATIONS

Environmental

- Operating Temperature: 0°C to 32°C
- Storage Temperature: 0°C to 65°C
- Humidity:
 - 5% to 90% RH, Non-Condensing, for temperatures 0°C to 40°C
 - 5% to 60% RH, Non-Condensing, for temperatures 0°C to 65°C
- Maximum Altitude of Operation: 3000m
- Maximum decibel level: 73 dB(A)

Electrical

- Motor Type: BLDC
 - Motor Phase Voltage: 160 Volts Pulse DC @ Controller Supply Voltage of 120 RMS, or 320 Volts Pulse DC @ Controller Supply Voltage of 230 RMS
- Duty Cycle: The Nutrunner tools are intended for intermittent operation with recommended maximum duty cycles not to exceed 33%. Note: actual maximum duty cycles are dependant upon several factors including ambient temperature, tool selection, joint conditions, fastening-parameter programming, and different applications and strategies. For optimum duty cycle determination, please contact your AcraDyne sales representative.

Physical

- Weight: 4.05 lbs (1.84 kg)

Performance

- Torque ranges:
 - AEP4P22030AV 18 – 30 Nm (13 – 22 ft-lbs)
 - AEP4P22050AV 25 – 50 Nm (18 – 37 ft-lbs)
- Max Speed: 1,578 RPM



AIMCO CORPORATE HEADQUARTERS
10000 SE PINE STREET
PORTLAND, OREGON 97216
PHONE: (503) 254-6600
TOLL FREE: 1-800-852-1368

AIMCO CORPORATION DE MEXICO SA DE CV
AVE. CRISTOBAL COLON 14529
CHIHUAHUA, CHIHUAHUA. 31125
MEXICO
PHONE: (01-614) 380-1010
FAX: (01-614) 380-1019

LIT-MAN378 REV. 11/2021
PRINTED IN USA ©2021